



MY ROBOT TIME

MRT3 Series

- MRT3 curriculum is developing for helping students(age 6 - 13+), through robotics, learn essential STEM (science, technology, engineering, and math) concepts.
- Step by step and systematic building instructions for MRT3 educational robot kits.

4
**Advanced
Level**

1
**Foundation
Level**

2
**Beginner
Level**

3
**Intermediate
Level**

MRT3-4. Advanced Level

CONTENTS

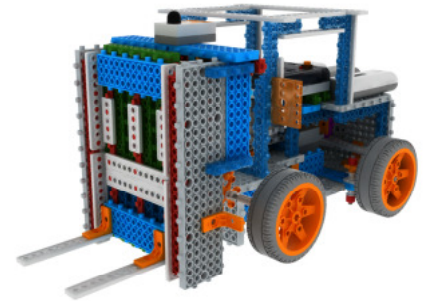

<i>Part list</i>	4
<i>What are we going to learn?</i>	7
○ STEM 1. It is so flashy! Light Energy	9
○ Robot Making1--Motor cycle	10
○ STEM 2. Having a motor cycle race with your friends	21
○ STEM 3. Let's move some objects! Conveyor	22
○ Robot Making2--Square Robot	23
○ STEM 4. I feel dizzy when I keep on turning and turning! Cams	32
○ STEM 5. You can't move anything without me.! Gear	33
○ Robot Making3--Golf Robot	34
○ STEM 6. The Ear of Robot—Sound Sensor (MIC)	46
○ STEM 7. Oh my God, Hot! Thermal energy	47
○ Robot Making4--Bulldozer	48
○ STEM 8. How can we use thermal energy?	60
○ STEM 9. I feel a twingel! My body is trembling—Electric Energy	61



○ Robot Making5—Mountain Motor Bike (4 wheels)	62
○ STEM 10. A transformation magician—Electric Energy	73
○ STEM 11. How a long slender thing can move a lot of things—Link	74
○ Robot Making6—Racing Car F1 (Tilting)	75
○ STEM 12. Having a racing car race with your friends	84
○ STEM 13. Intelligent robots acting like human	
—AI 1 (Artificial Intelligence)	85
○ Robot Making7—Fork Lift	86
○ STEM 14. Systems that use AI	104
○ STEM 15. Robot simulating humans—AI 2 (Humanoid)	105
○ Robot Making8—Bowling Robot	106
○ STEM 16. Other Humanoid	116
○ STEM 17. Rules to follow—Robotic Ethic	118
○ Robot Making9— TANK	119



Part list

Block

※ The form and color of some parts may be different when compared to actual parts due to continues improvement of production quality.

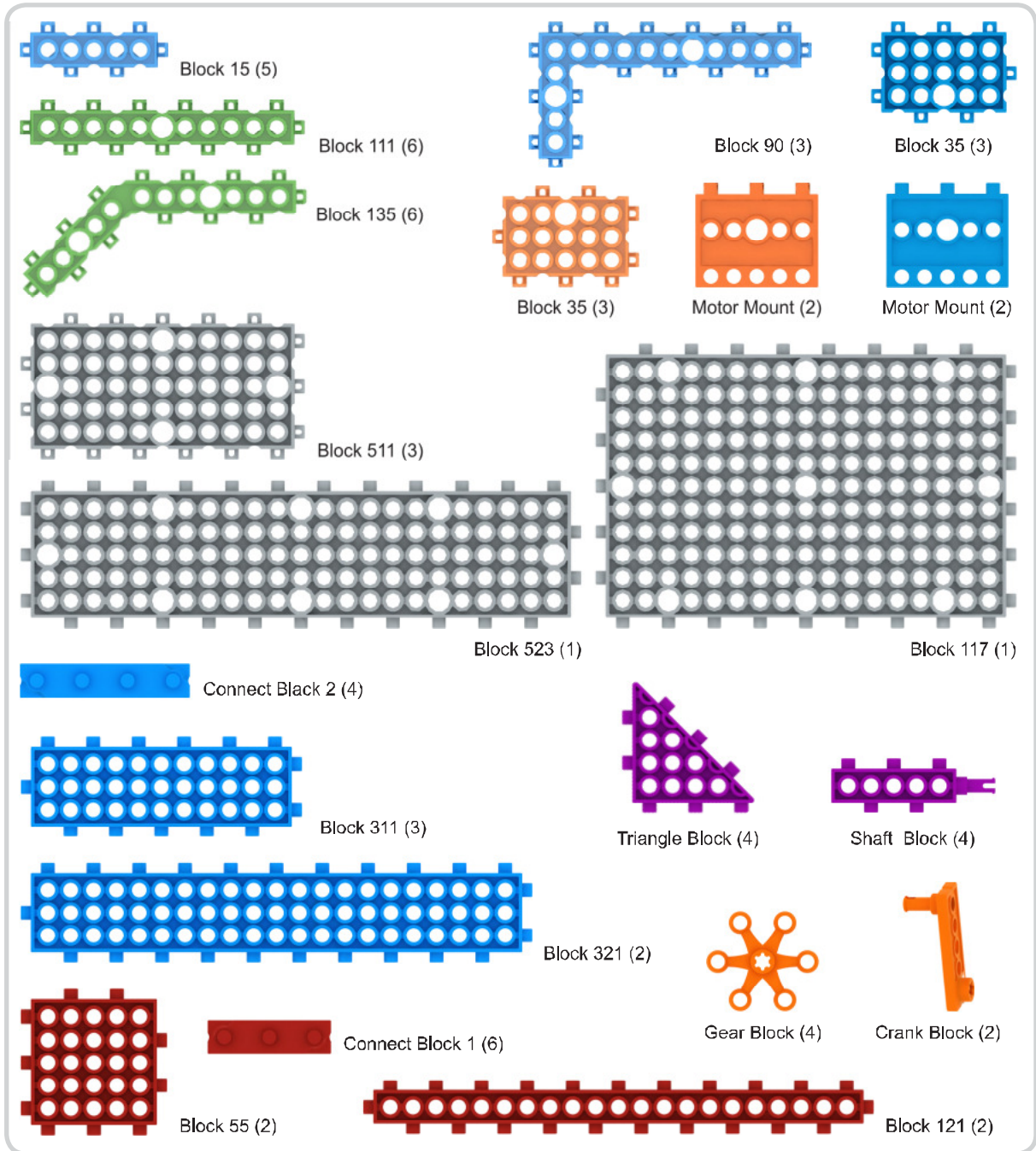

Frame / Adapter

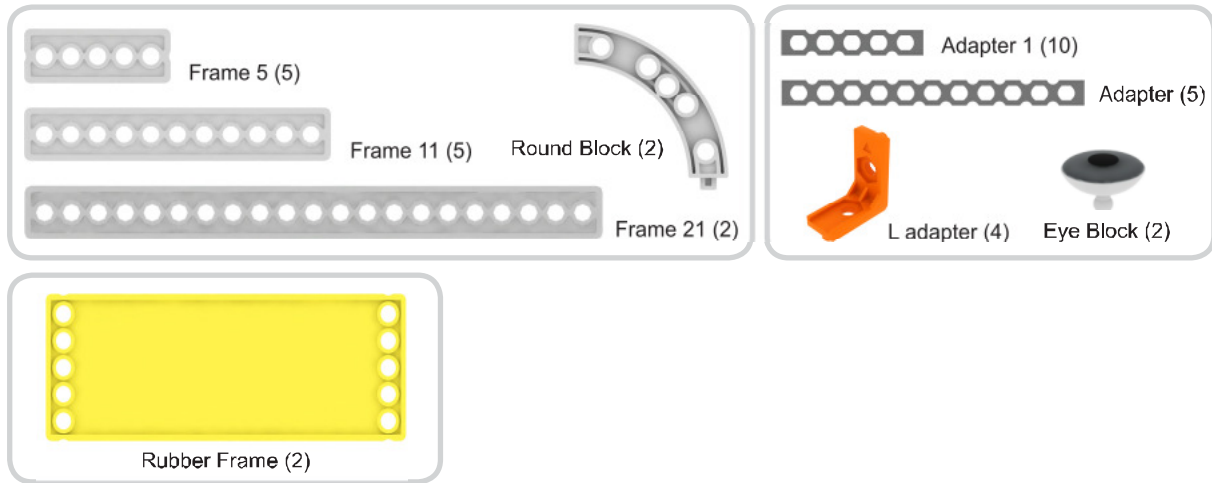

Wheel / Gear / Frame

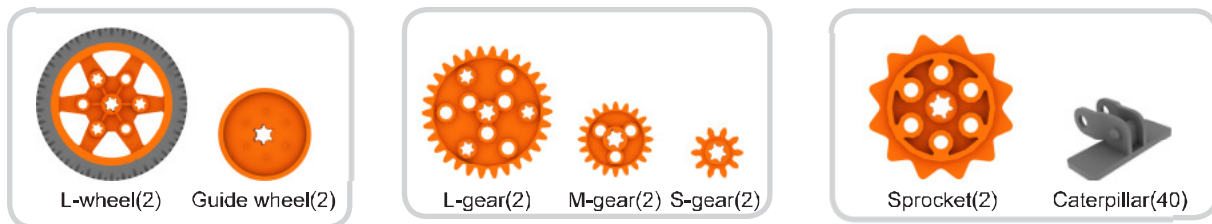

Shaft / Bush



Electronic Parts



Buzzer Sensor

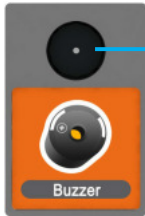

Buzzer Board

Displays received signals from the mainboard with sound.
(Please remove seal when using!)

Mic Sensor



Mic Sensor

Detects sounds from outside and converts them into electrical signals.

Setting remote control ID

- ① Turn on the robot.
- ② Connect RC receiver board to R/C connector.
- ③ Press **CH** button while holding **↵** button. The **A** panel ID LED turns on and shows you what mode you chose.
- ④ Press **CH** button while holding **↵** button and choose your ID. (Number 1~8)
- ⑤ After selecting ID, if you release **↵** Button and press **CH** button, ID will be selected.
- ⑥ The LED on the mainboard will blink 3 times and it will turn off automatically.

That means the ID Selection is finished.

- ⑦ If you press **↵** button, you can see your selected ID.

※ If there is a problem, repeat steps 1-7 carefully.

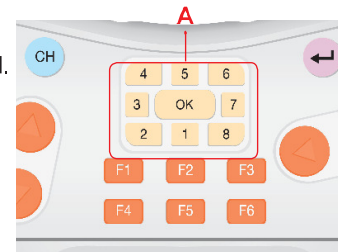

How to set up communication ID

- ※ The maximum number of channels can be set as shown below without interference.
Use the picture to assign the channels to the communication ID.

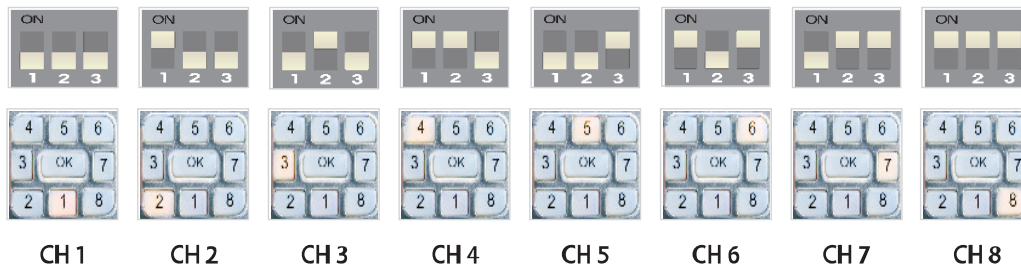



What robots are we going to assemble?



1. Motor cycle

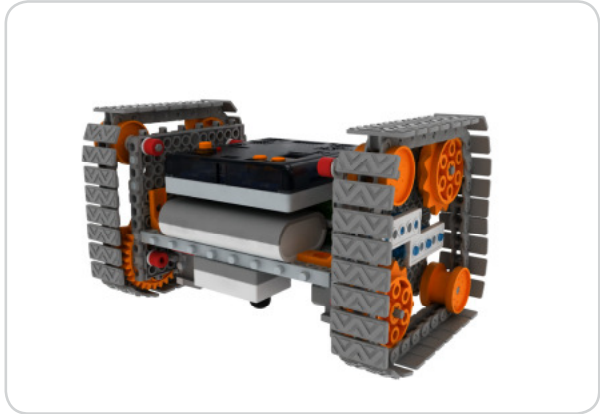

2. Square Robot



3. Golf Robot



4. Bulldozer



5. Mountain Motor bike

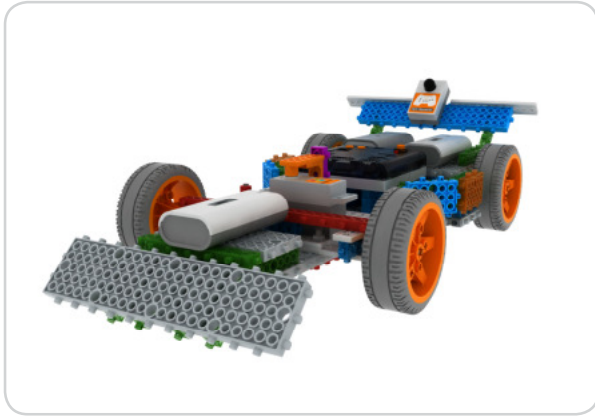

6. Racing Car F1

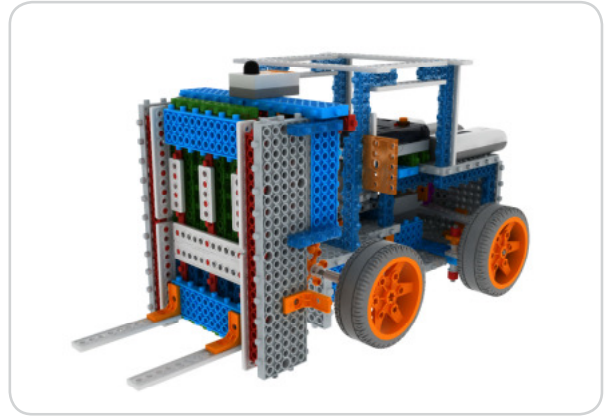

7. Fork Lift



8. Bowling Robot



9. TANK

S Science **STEM 1. It is so flashy!
- Light Energy**

1 Hey, Huna! Our family moved in to a new house. It's a greathouse because it gets a lot of sunshine.

It's good for you to get enough sunlight. These days, we can also create electricity with sunlight.

2 Wow, can you create electricity with it?

3 Yes! Originally, batteries created electricity. But with solar cells, we can store sunlight in the form of electricity.

4 So, does that technology use sunlight?

Right, Also, for a long as the sun exist well be able to continuously use light energy.

5 However, we haven't developed much technology using light energy yet. So It is not used extensively. We can't use light energy directly and it requires special facilities. There is so much light energy from the sun, but actually the amount of light energy in use is very small.

6 So,we can't use all of it?

However, this light energy is eco-friendly, it will be used in the future.



Engineering
Art

Robot Making 1-Motor cycle



1

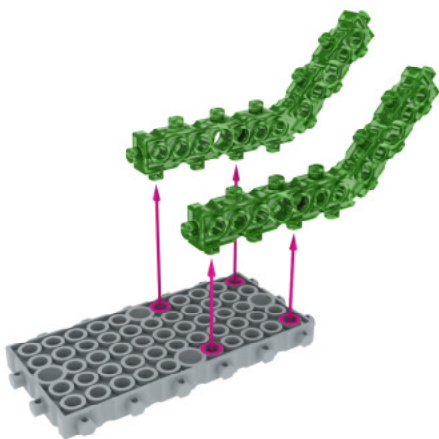

2

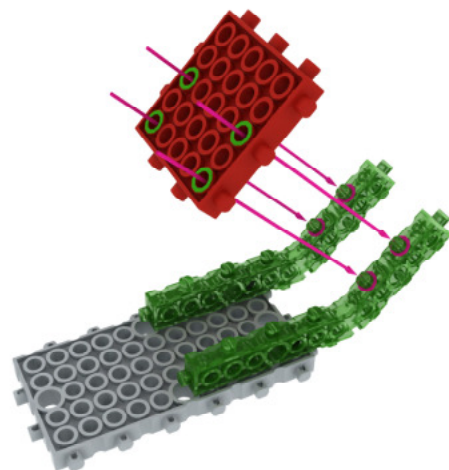

3

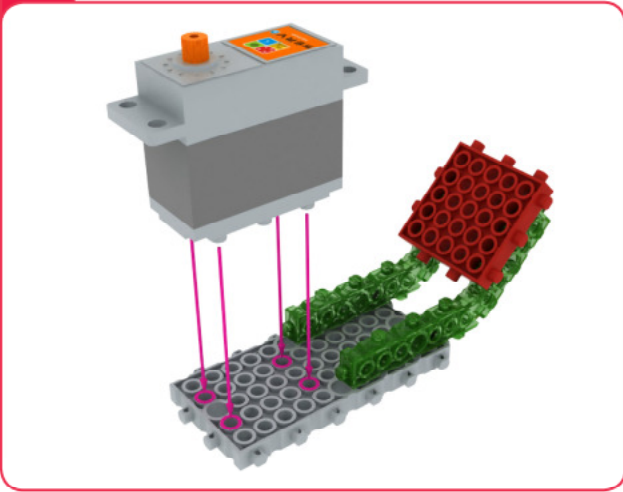

4

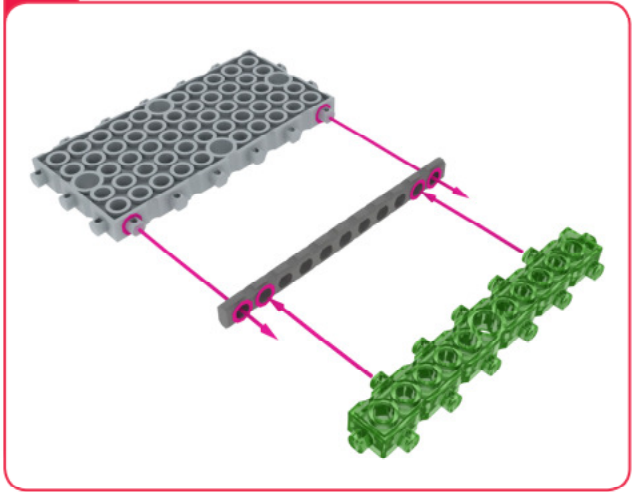

5

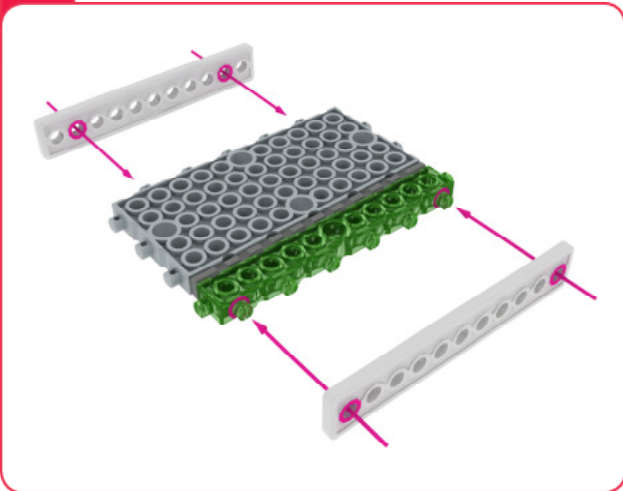

6

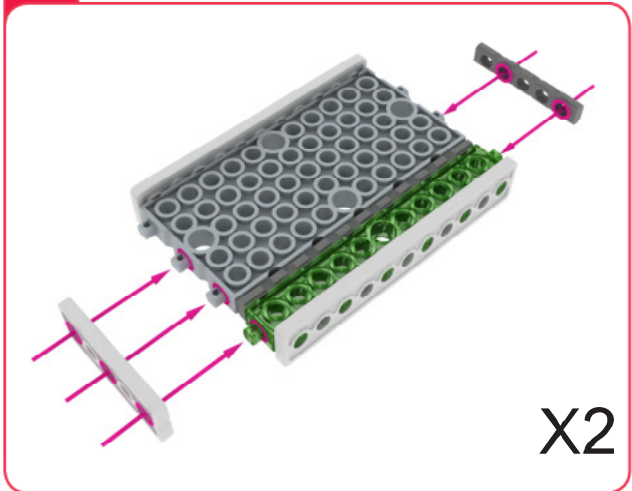

7

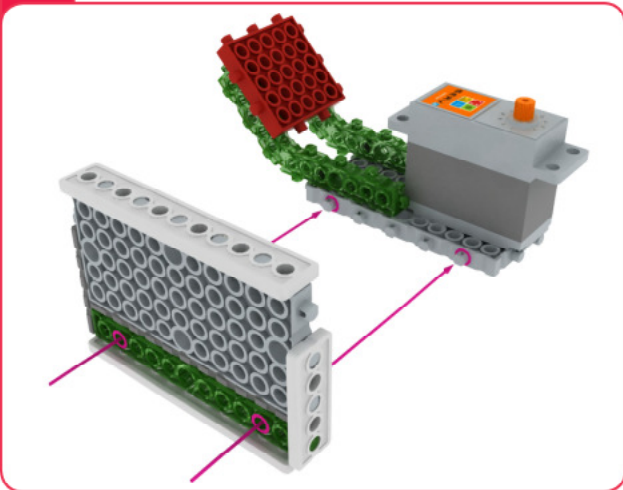

8

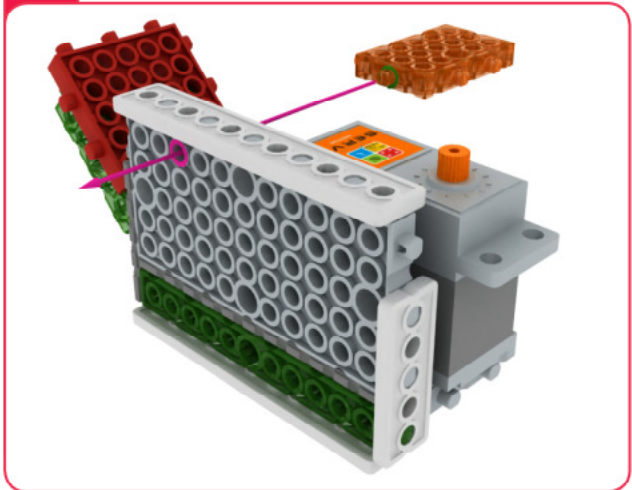

9

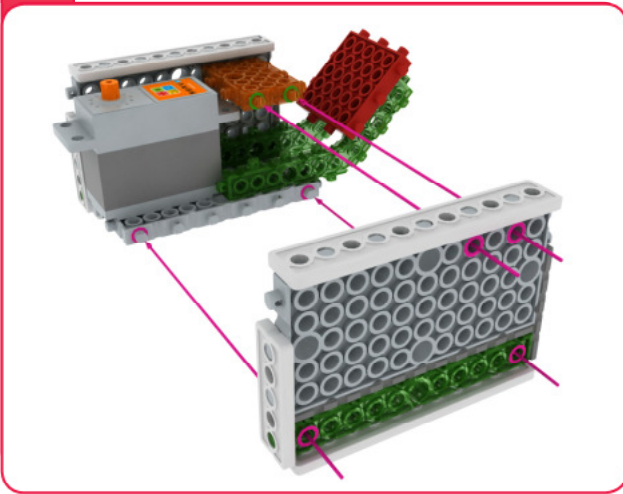

10

X1 X1

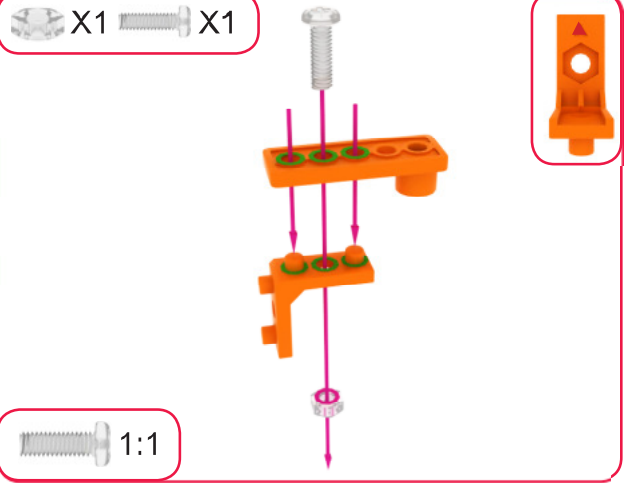

1:1

11

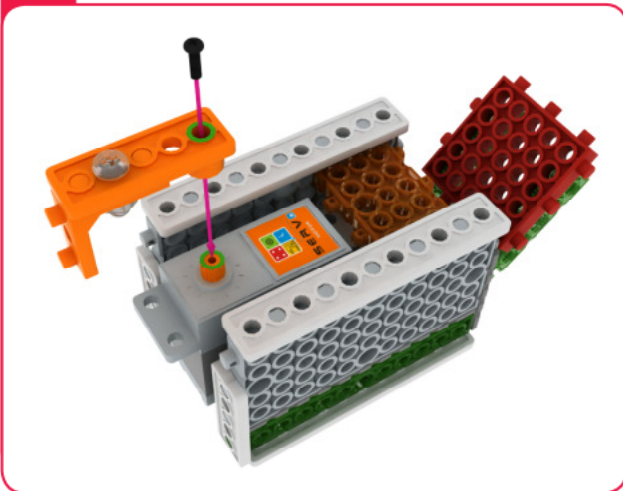

Servo Motor-Zero Point Adjustment

1. Connect the servo motor to the mainboard. You can write the program in the following way.

```

PROGRAM
START {
  Servo:[Servo 1(OUT1)]=[0]
END}
    
```

2. After downloading the program, power off and on again.
3. Fix servo motor horn to the servo motor with a small servo bolt as illustrated in the picture .

12

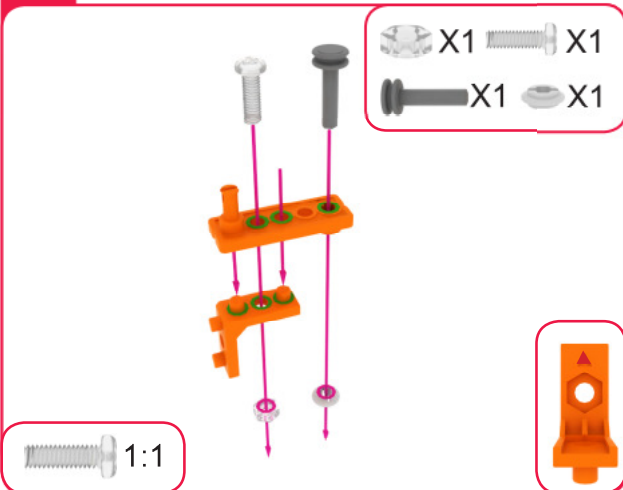

X1 X1
X1 X1

1:1

13

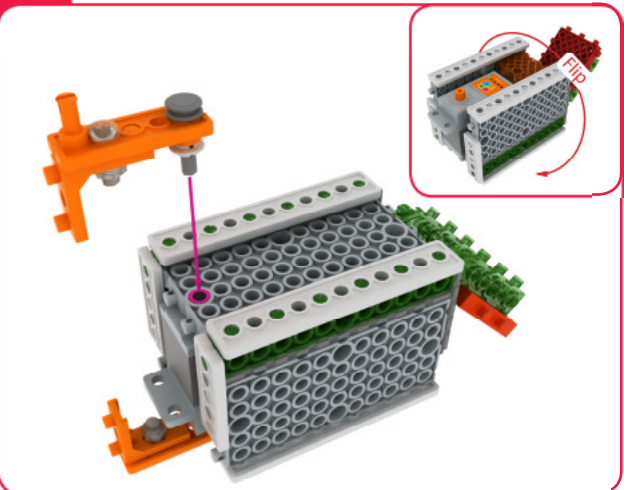

14

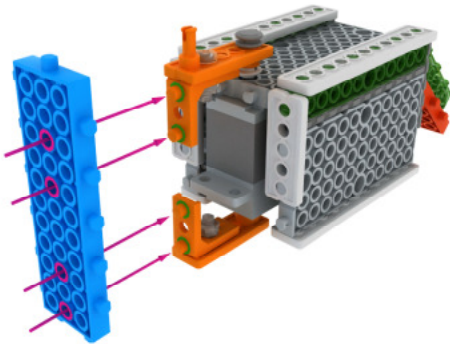

15

X2

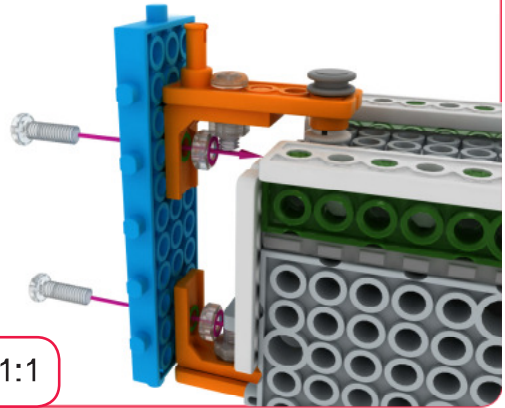

1:1

16

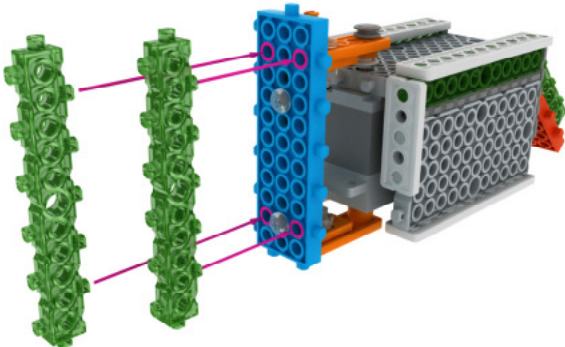

17

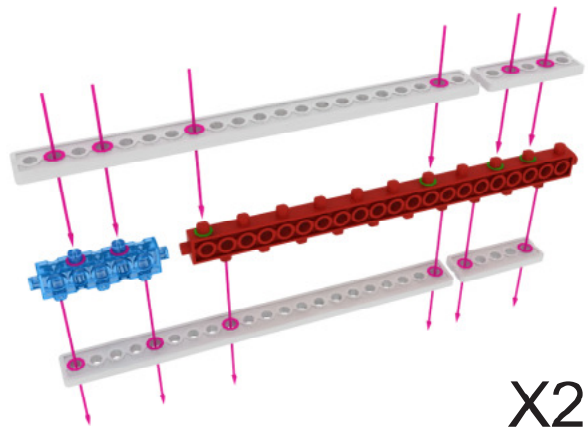

X2

18

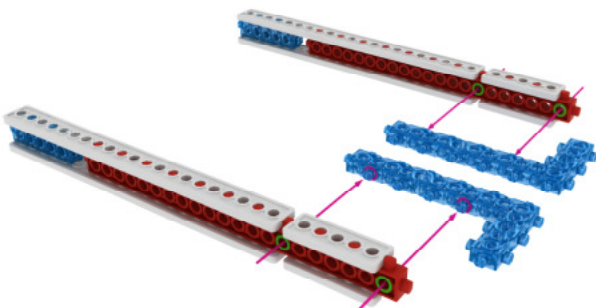

19

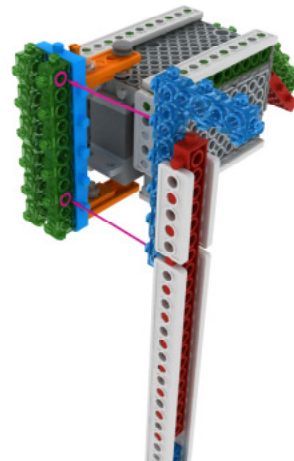

MY ROBOT TIME

20

X2 X1 X2
X1

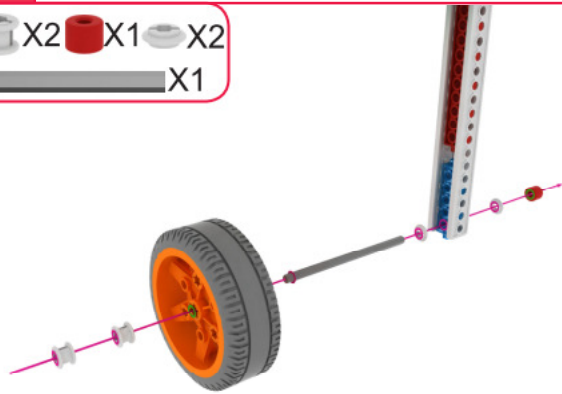

1:1

21

X1 X1

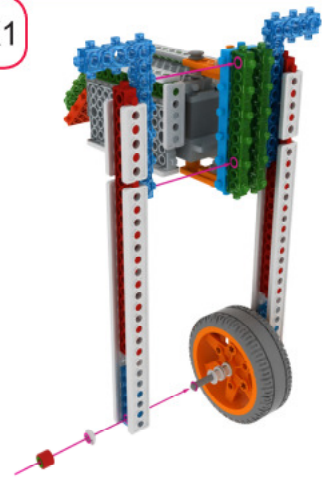

22

X1

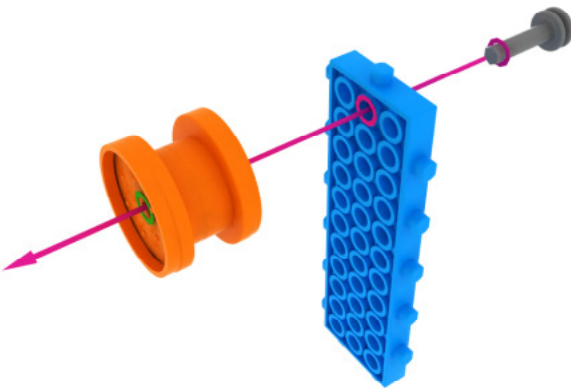

23

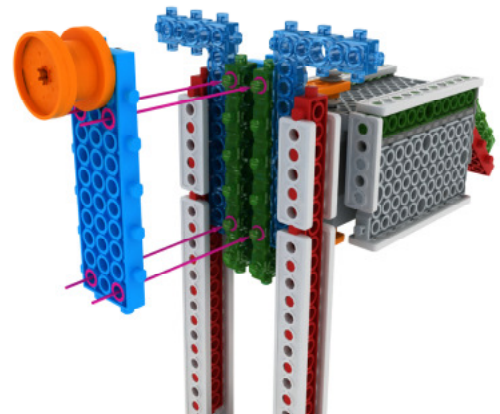

24

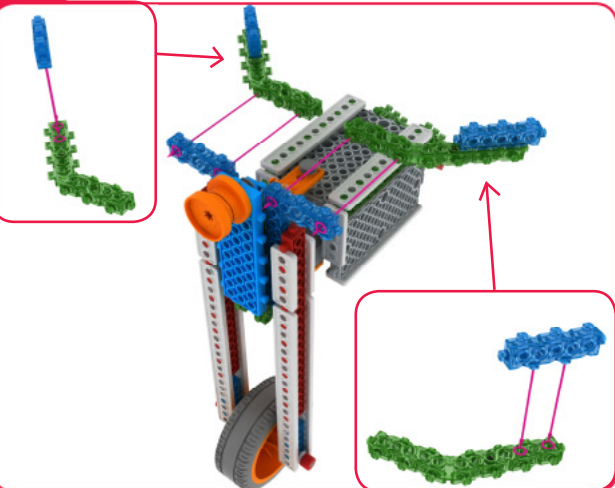

25

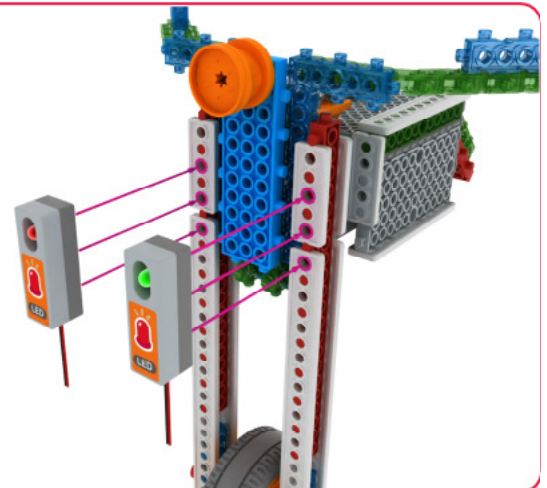

38

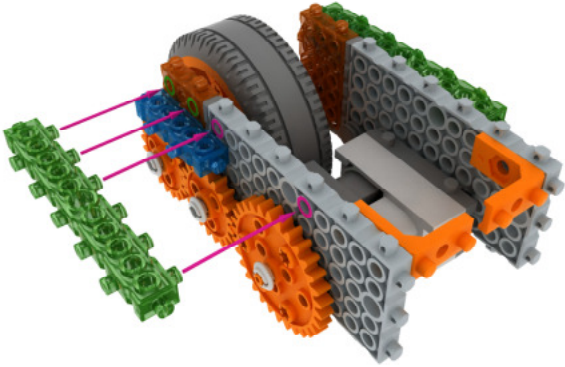

39

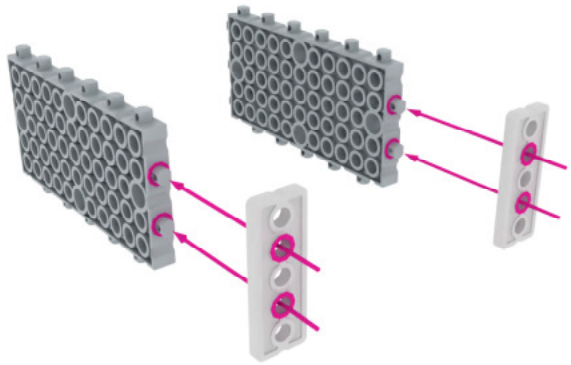

40

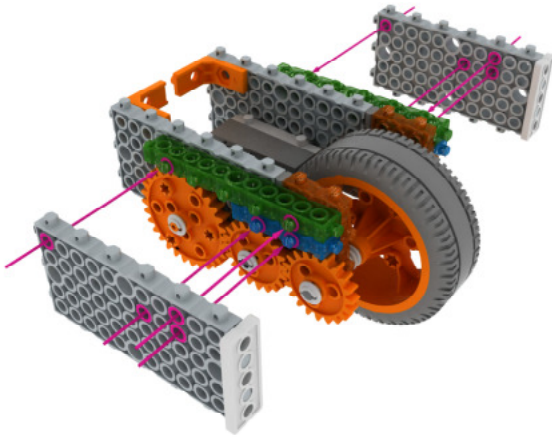

41

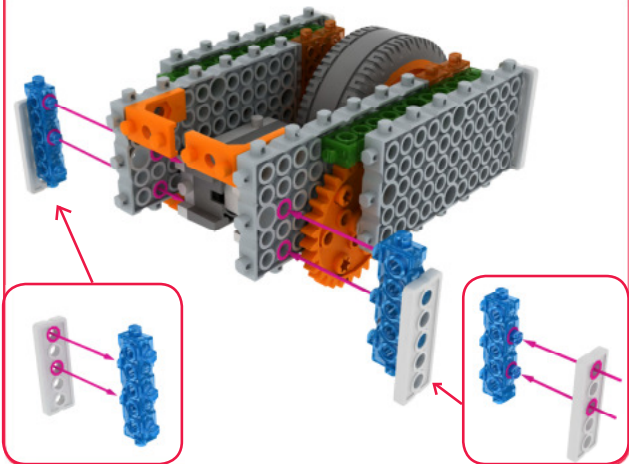

42

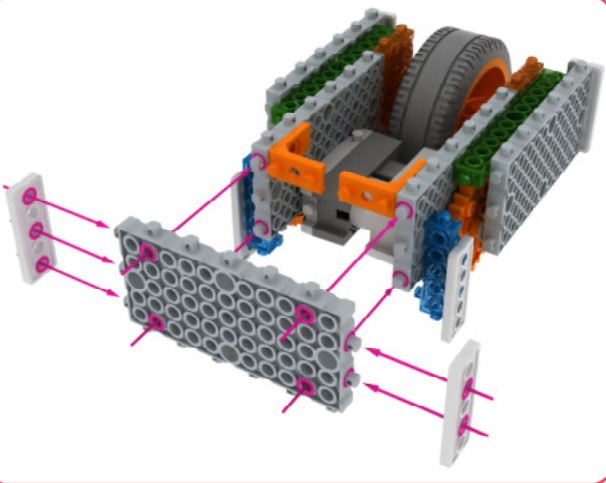

43

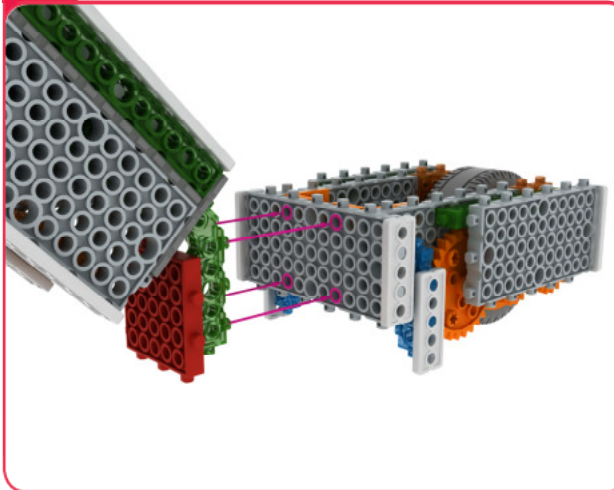

44

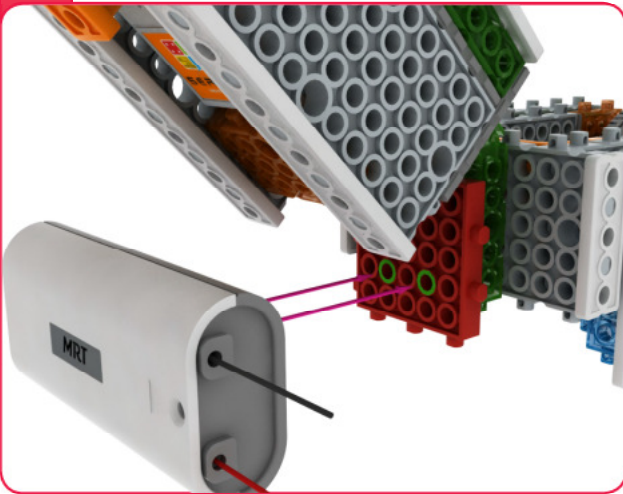

45

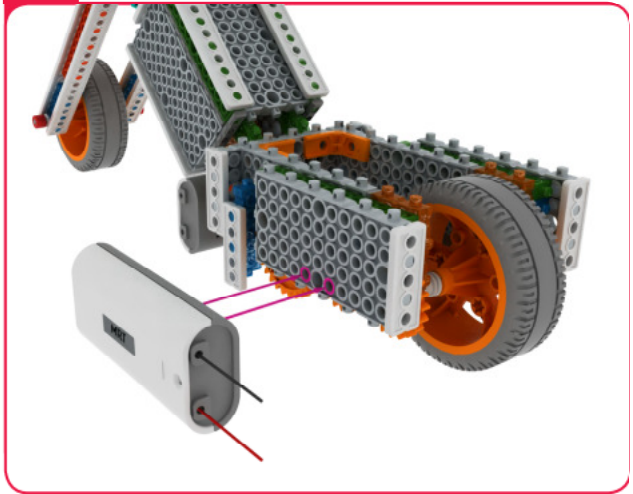

46

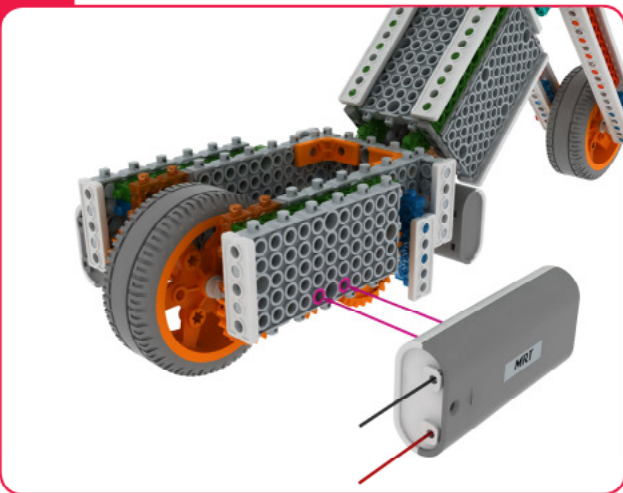

47

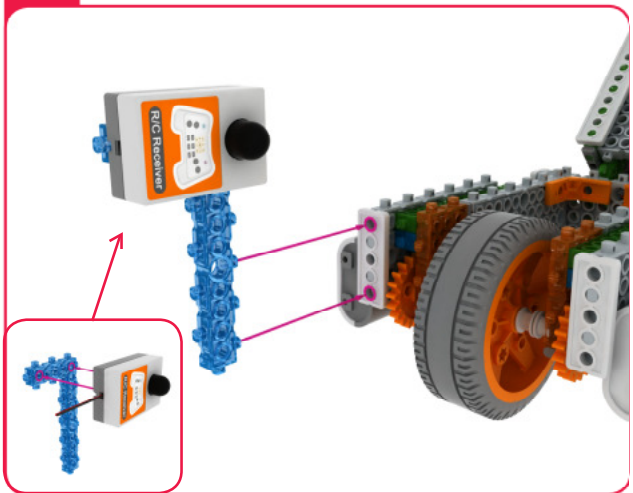

48



End





How to operate the Motor cycle

Connecting the main board

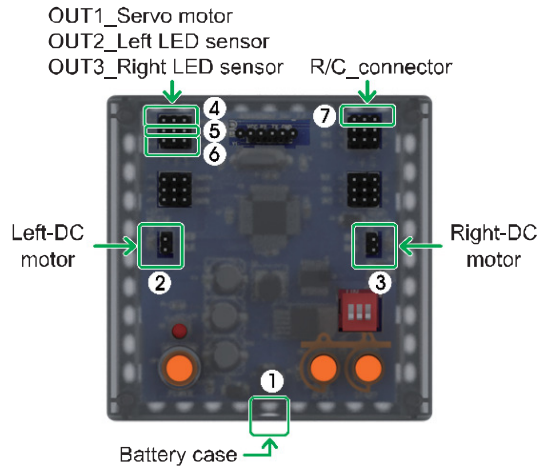

Connect in this order.

1. Connect Battery Cases to Power connector.
2. Connect Left-DC motor to Left-motor connector.
3. Connect Right-DC motor to Right-motor connector.
4. Connect Servo motor to OUT1 of OUTPUT connector.
5. Connect Left LED sensor to OUT2 of OUTPUT connector.
6. Connect Right LED sensor to OUT3 of OUTPUT connector.
7. Connect RC receiver board to R/C connector.

Motion Pattern/Program

Turn left (Servo +45)



Go Forward (Servo 0)



Turn Right(Servo -45)



※ Using the motion patterns as reference, let's write the program.

Program Download

1. Write the program.
2. Make sure Power / DC Motor connector and sensor's connector are well connected.
3. Check the power OFF state, then insert the download cable.
4. 'SAVE' and click the 'DOWNLOAD' button on the program window.
5. Turn on the power when 'DOWNLOAD' window opens. (Power ON)
6. Once the download is completed, remove the download cable and then turn the power off and on.
(Power OFF → Power ON)



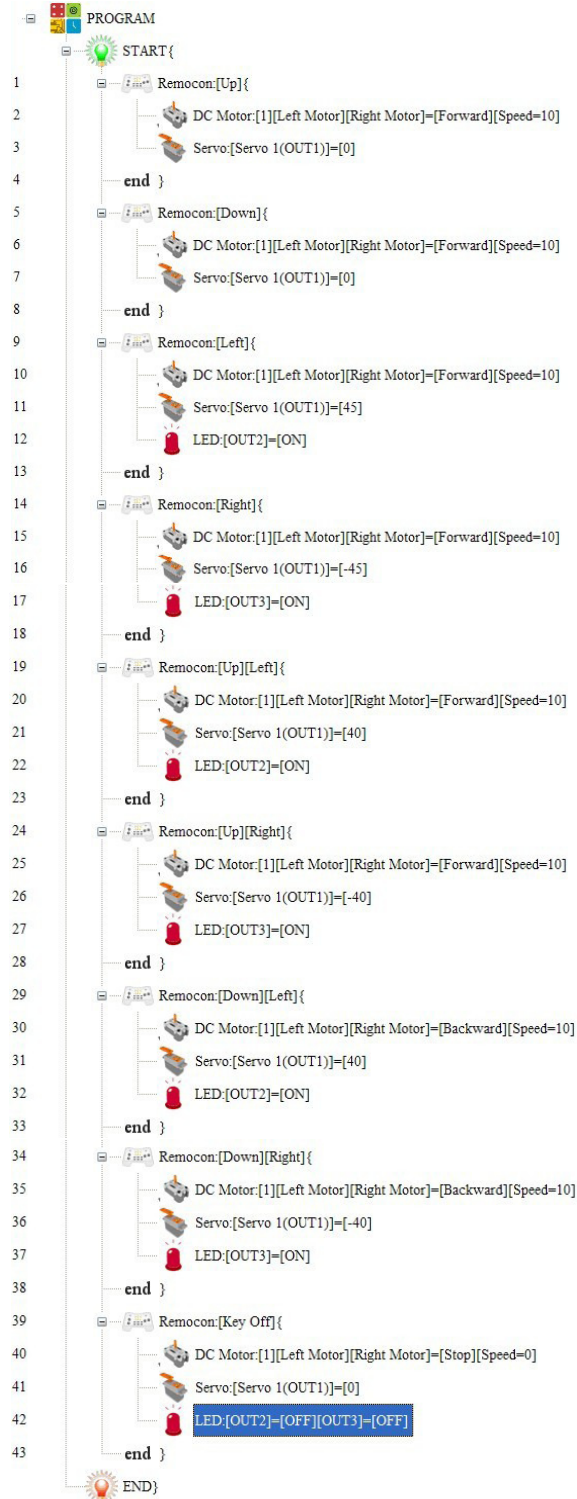

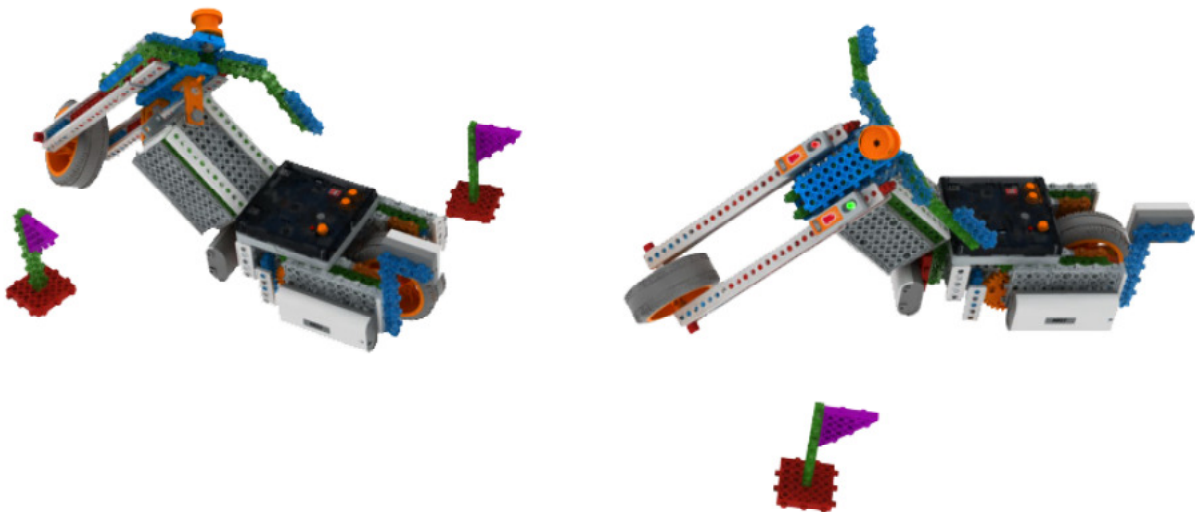
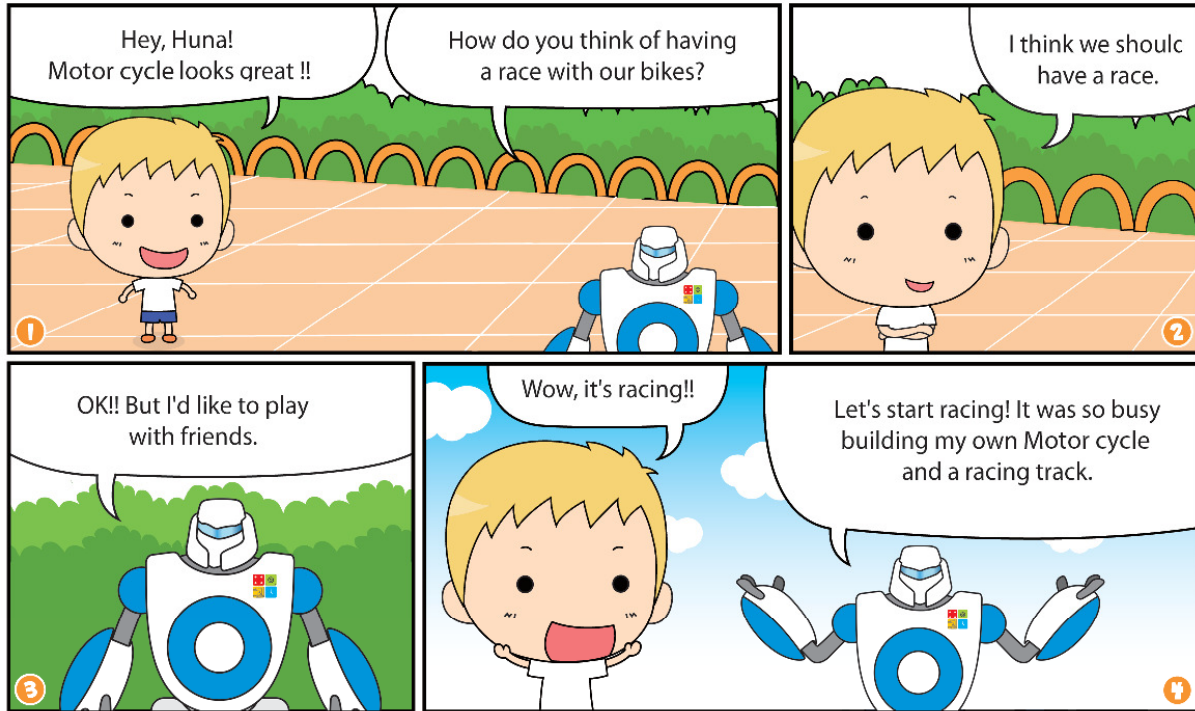

Program Example

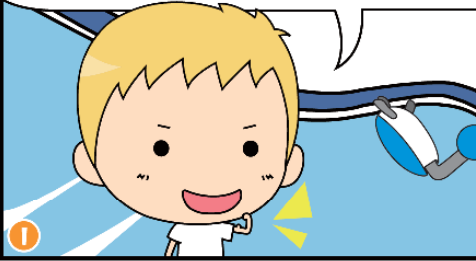
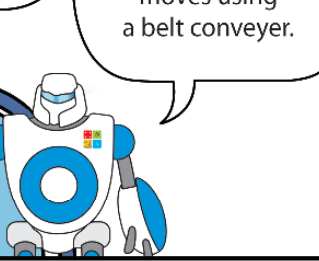
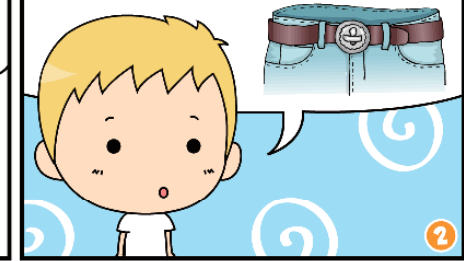
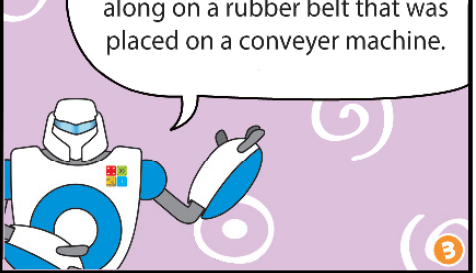

T Technology
E Engineering **STEM 2. Having a Motor cycle race with your friends**

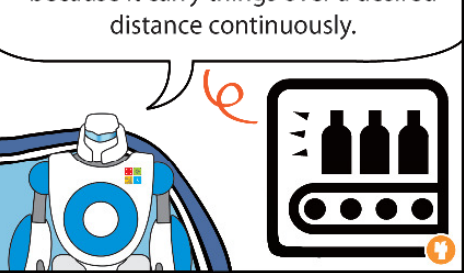
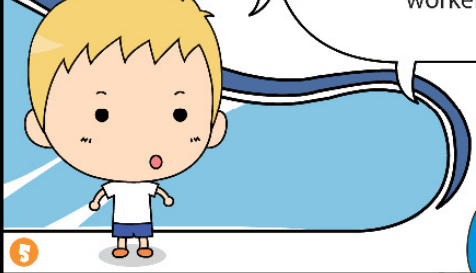

※ Let's play a Motor cycle race with your friends.

<p>A escalator at a department store is powerful. Because no matter how many people there are, it can carry them.</p>  <p>1</p>	<p>That's right~!! A escalator moves using a belt conveyer.</p> 	<p>A belt conveyer? Is that a belt around our waist?</p>  <p>2</p>
<p>Ha ha.. No no.. A belt conveyer is machine that move objects along on a rubber belt that was placed on a conveyer machine.</p>  <p>3</p>	<p>Then, what is a conveyer?</p> 	<p>A conveyer is a mechanism that carries objects. It is frequently used in factories because it carry things over a desired distance continuously.</p>  <p>4</p>
<p>So, they use it a lot especially in factories?</p>  <p>5</p>	<p>Um.. A heavy object is moved and time is saved. It is used as a moveable worktable for factory workers. Because of this, time can be saved in the manufacturing process.</p> 	
<p>There are many ways to manufacture things in a factory. Apart from a belt conveyer, are there any other uses for the conveyer?</p>  <p>6</p>	<p>Sure! There are many ways~. There is a chain conveyer that convey objects with a chain that hangs and there is a fluid conveyer that convey a object with water in a huge pipe.</p>  <p>7</p>	



Engineering
Mathematics

Robot Making 2- Square Robot

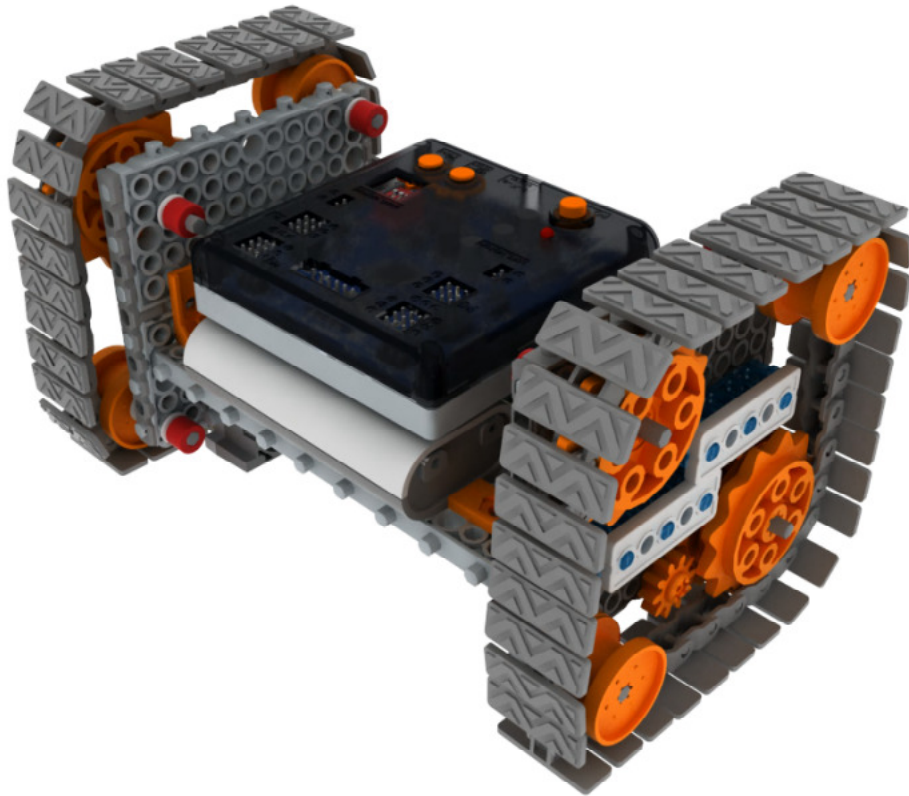

1

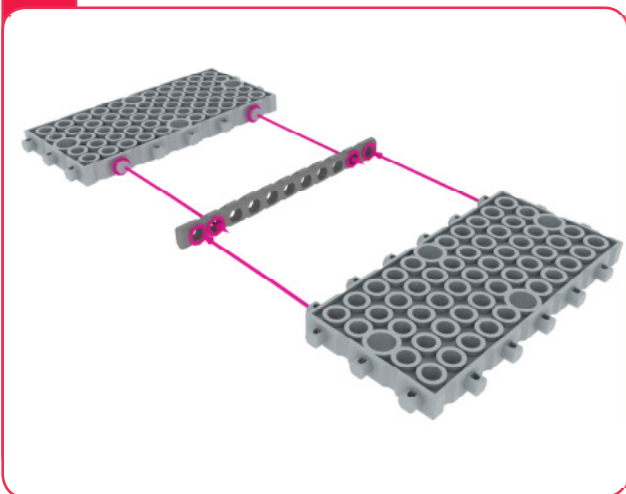

2

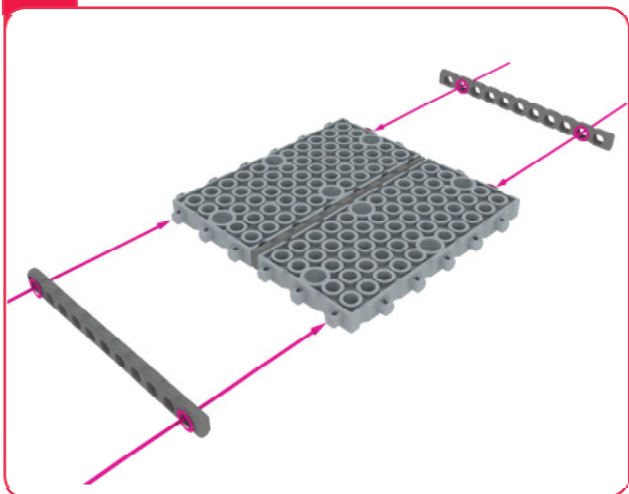

MY ROBOT TIME

3

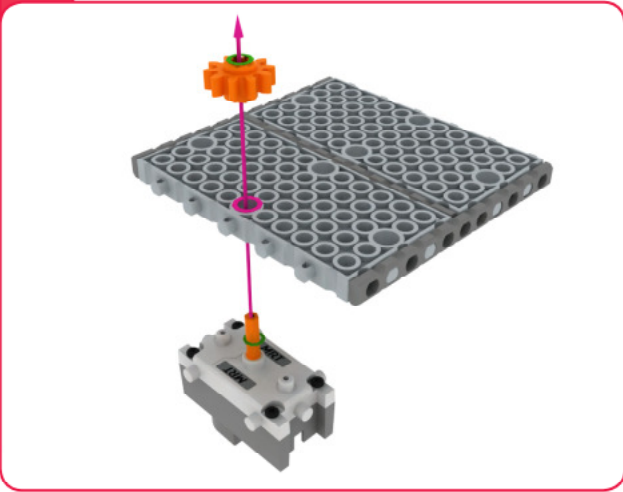

4

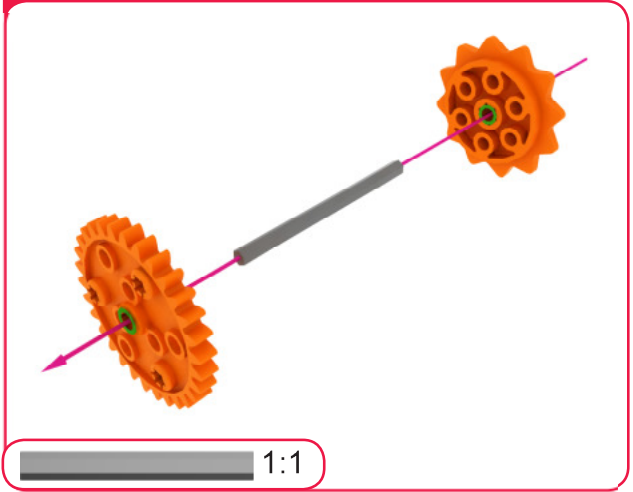

5

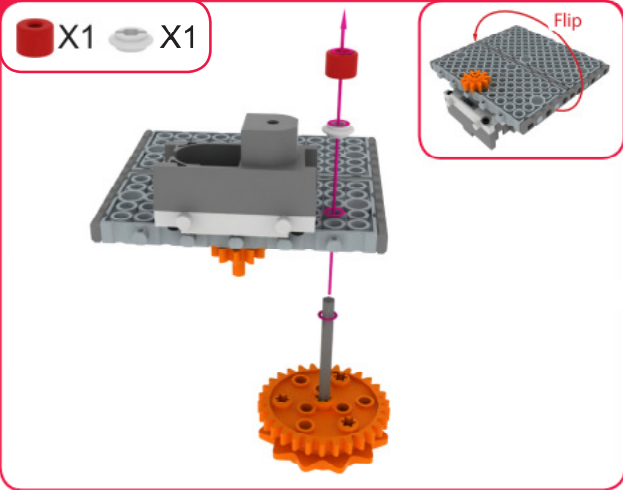

6

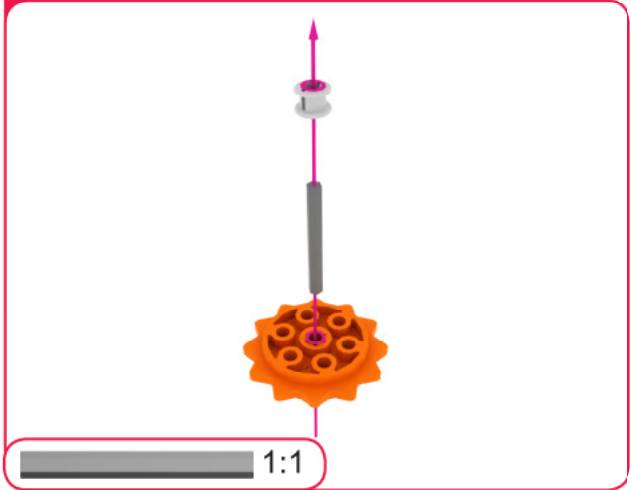

7

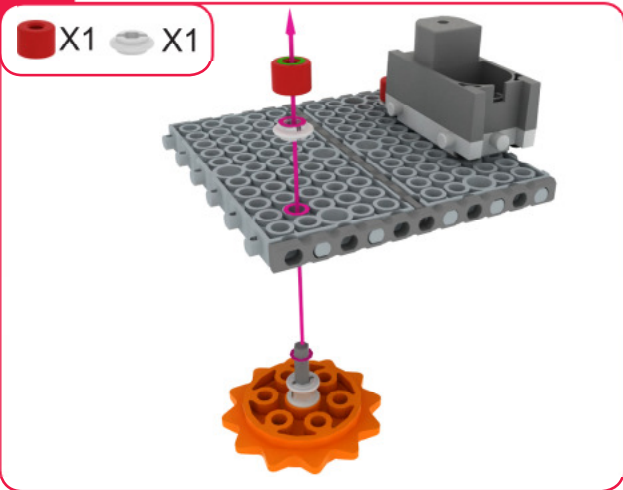

8

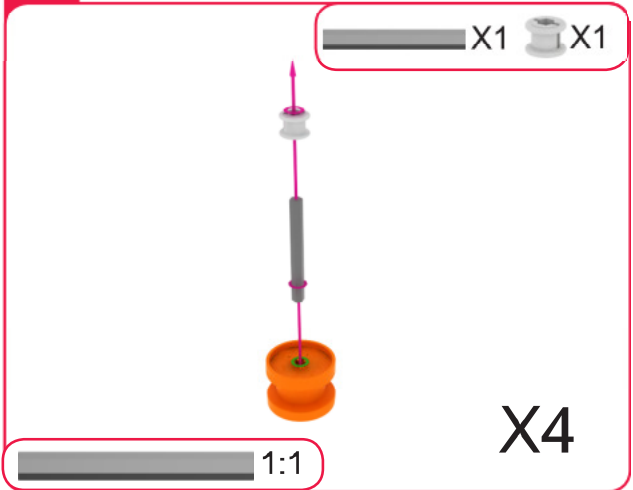

9

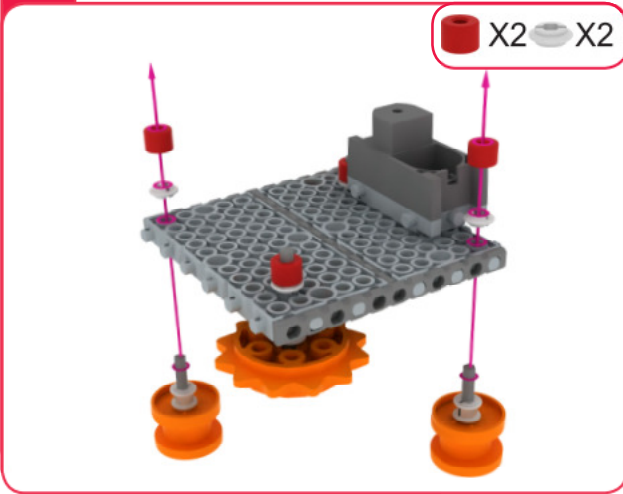

10

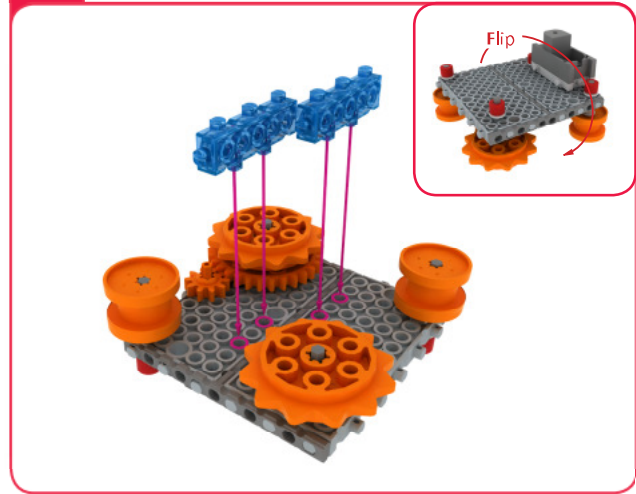

11

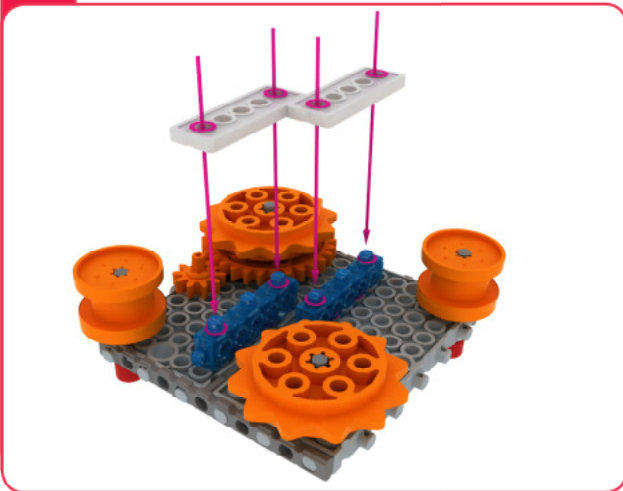

12

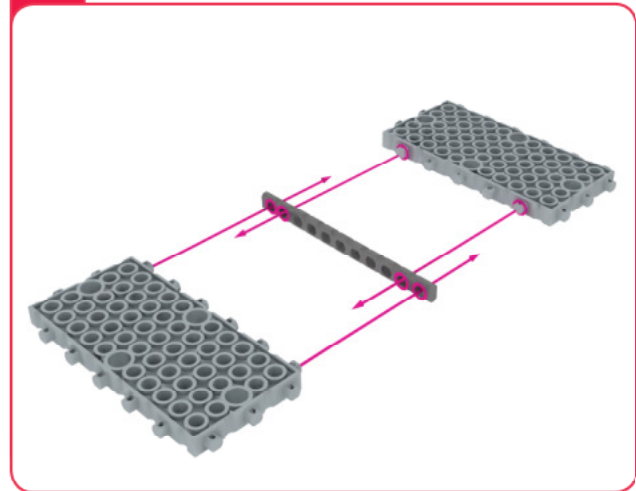

13

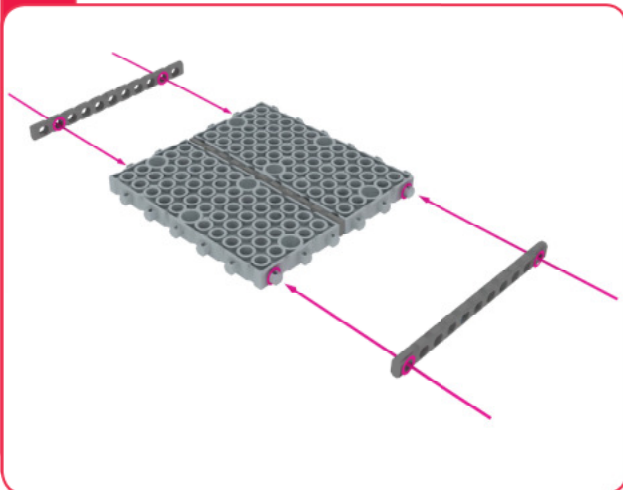

14

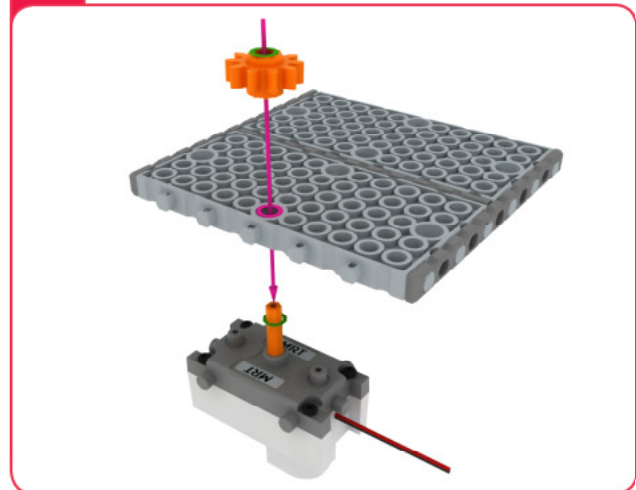

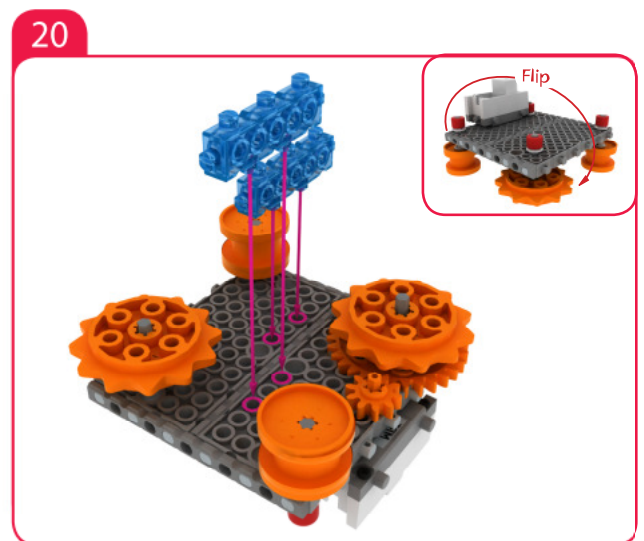
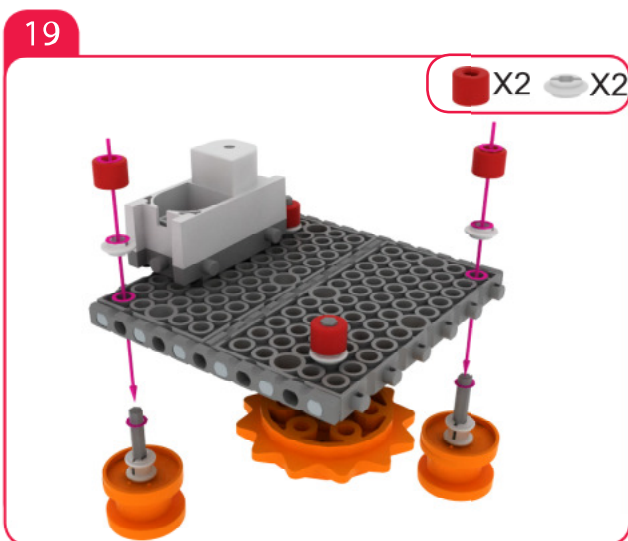
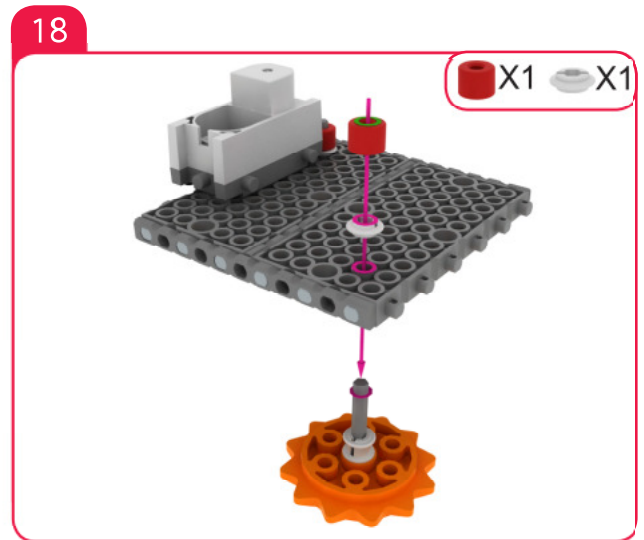
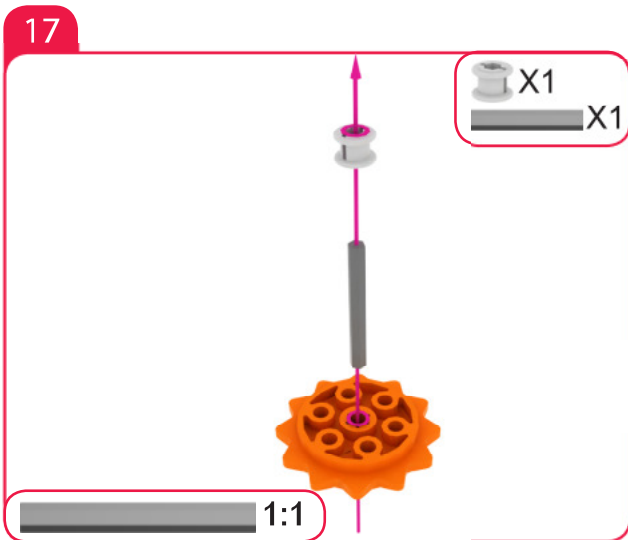
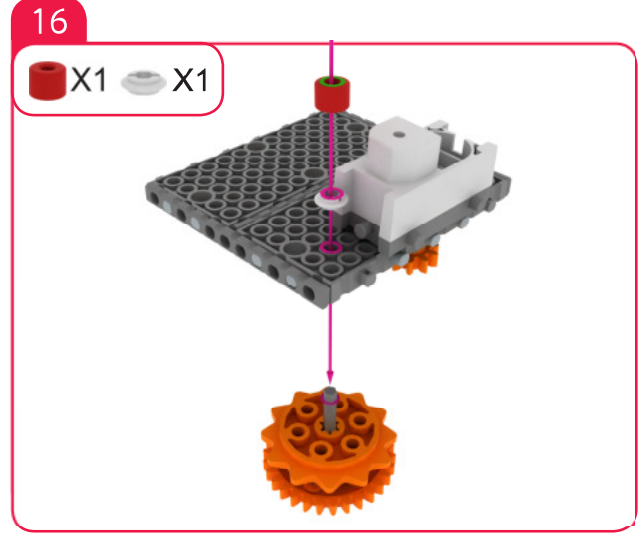
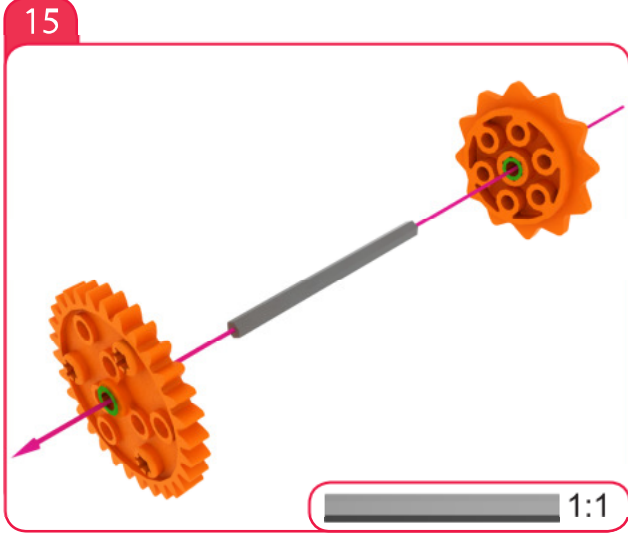

21

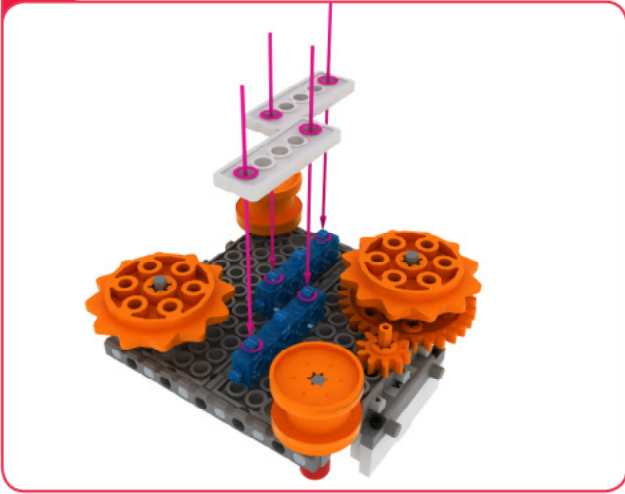

22

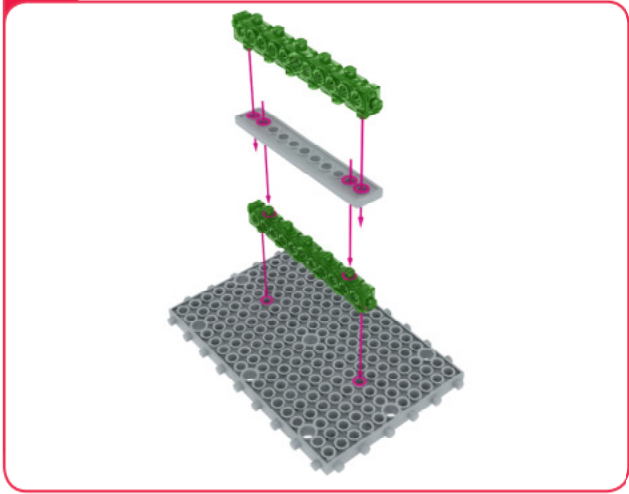

23

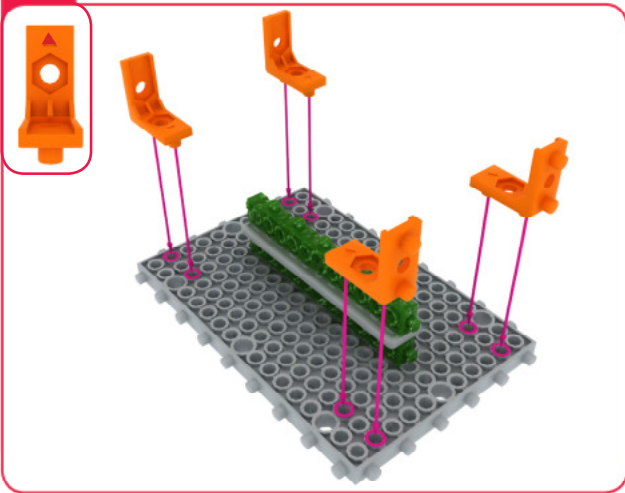

24

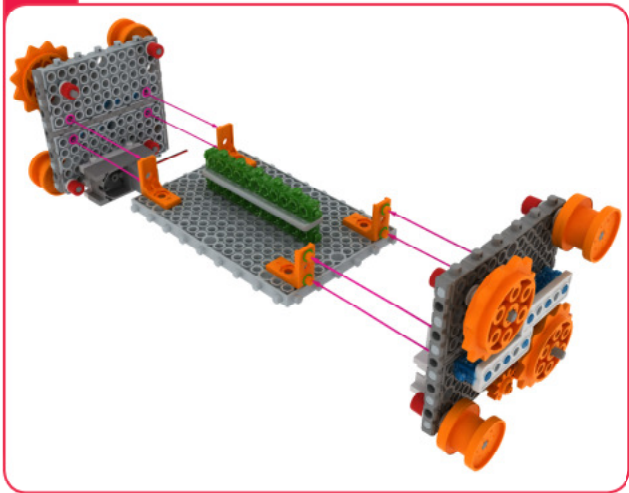

25

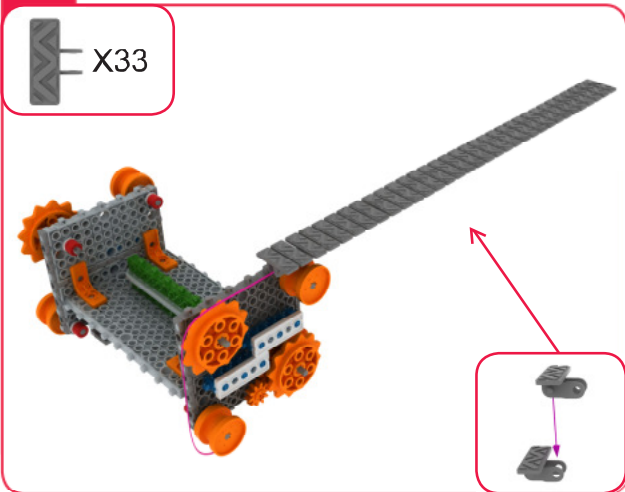

26

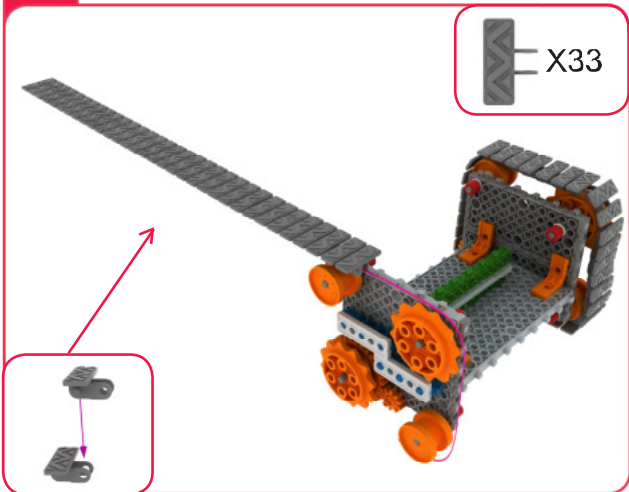

MY ROBOT TIME

27

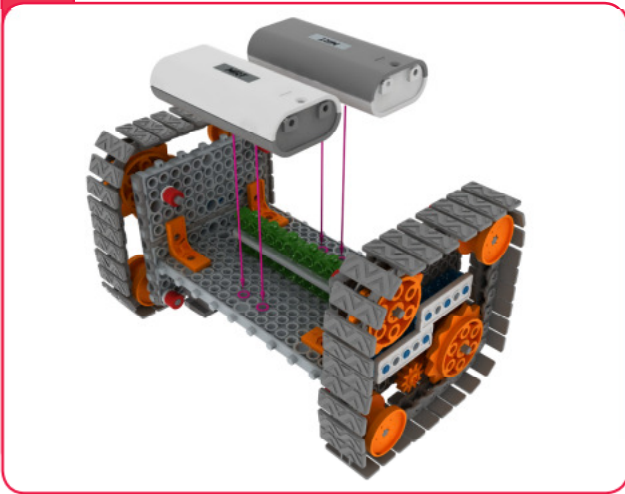

28

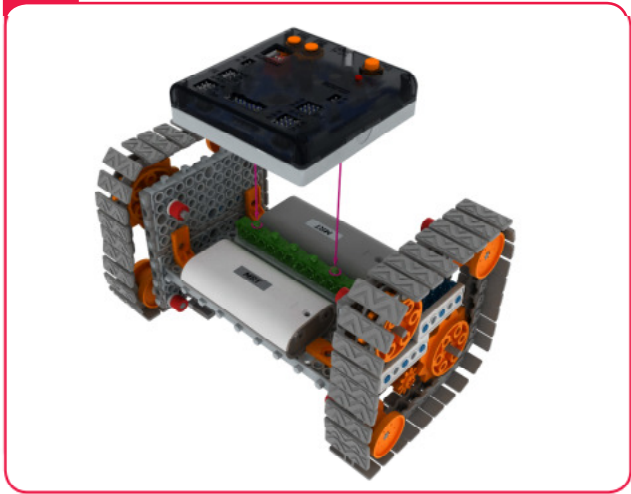

29



30

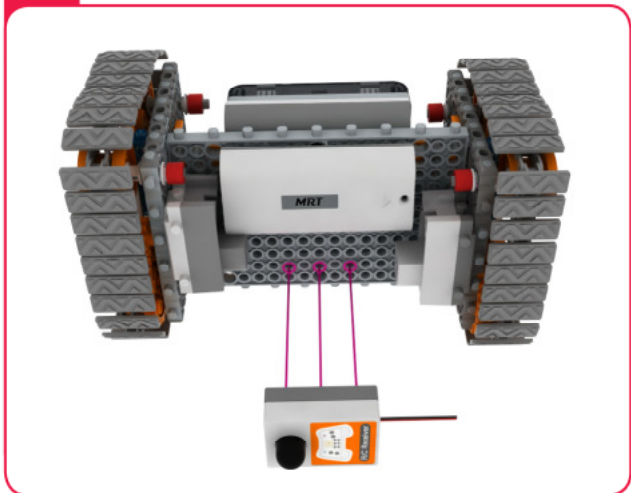

End

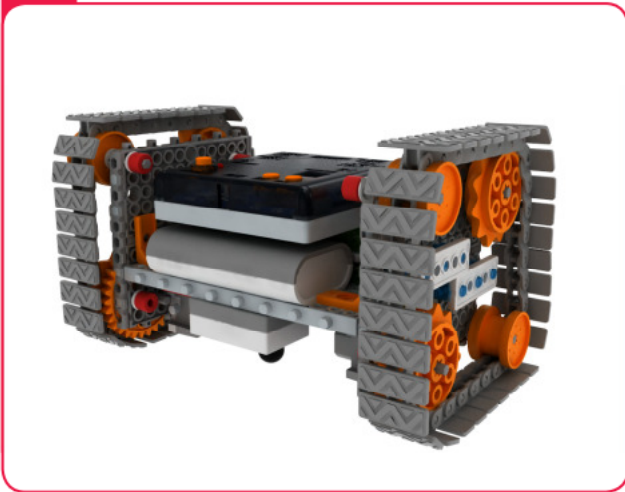

 How to operate the Square robot

Connecting the main board

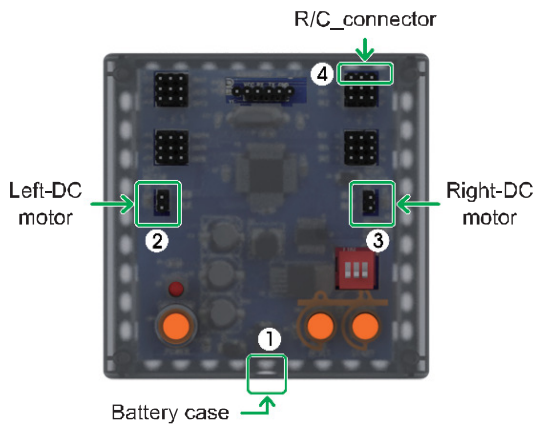

Connect in this order.

1. Connect Battery Cases to Power connector.
2. Connect Left-DC motor to Left-motor connector.
3. Connect Right-DC motor to Right-motor connector.
4. Connect RC receiver board to R/C connector.

Motion Pattern/Program

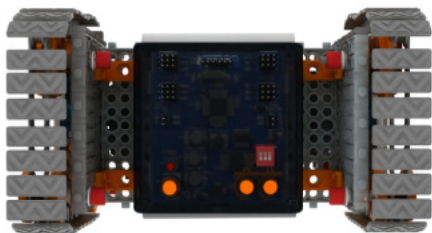

Remocon key	Left Motor	Right Motor
Up	Backward	Backward
Down	Forward	Forward
Left	Forward	Backward
Up + Left	Stop	Backward
Right	Backward	Forward
Up + Right	Backward	Stop
KEY OFF	Stop	Stop

※ Using the motion patterns as reference, let's write the program.

Program Download

1. Write the program.
2. Make sure Power / DC Motor connector and sensor's connector are well connected.
3. Check the power OFF state, then insert the download cable.
4. 'SAVE' and click the 'DOWNLOAD' button on the program window.
5. Turn on the power when 'DOWNLOAD' window opens. (Power ON)
6. Once the download is completed, remove the download cable and then turn the power off and on.
(Power OFF → Power ON)

Program Example

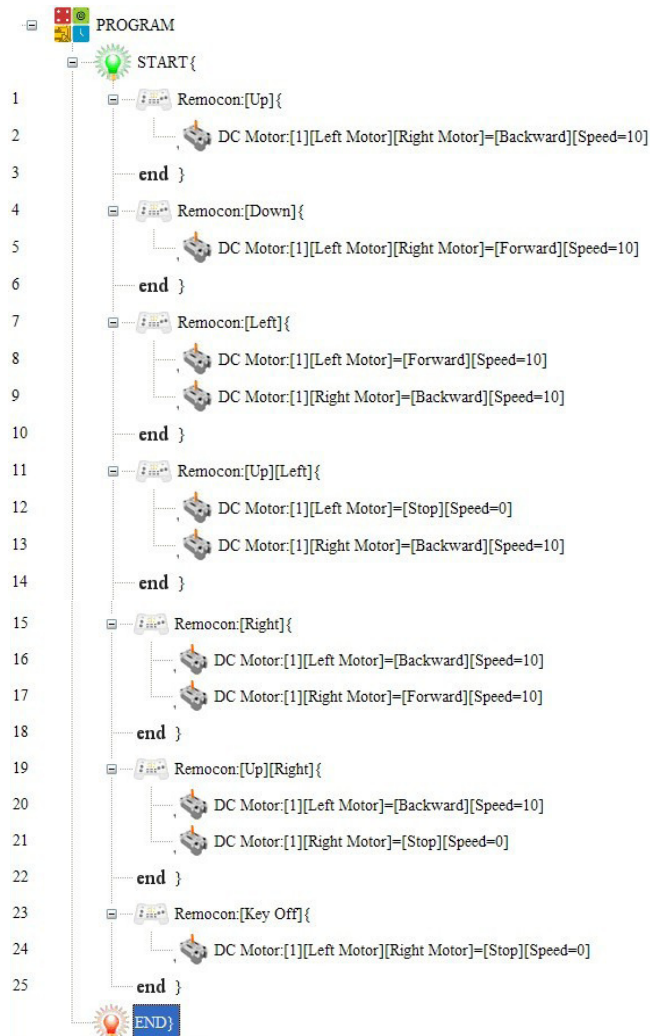

 **Art Square Robot Mission Competition**

Obstacles

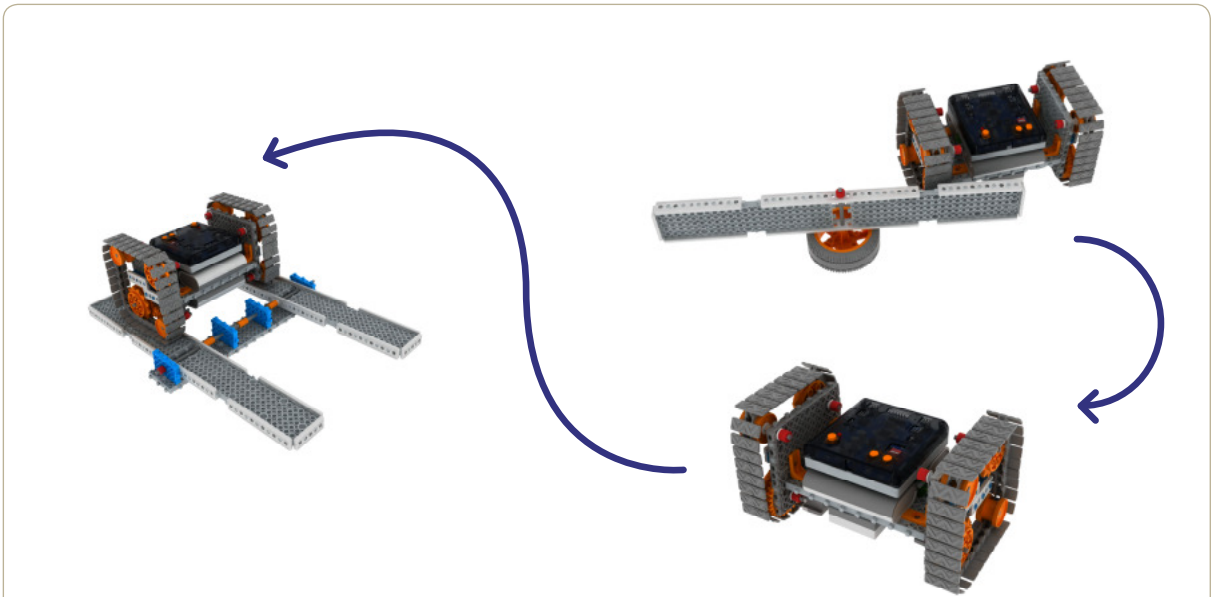
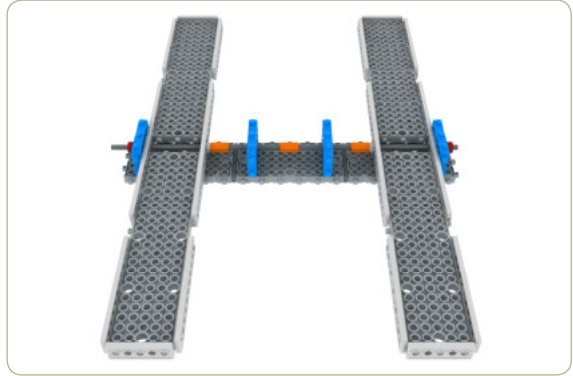
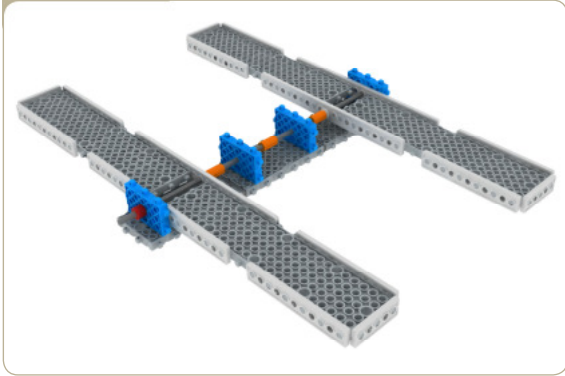

※ After making obstacles with rest of blocks, Let's play avoiding obstacles game with your friends.



Science

Technology

STEM 4. I feel dizzy when I keep on turning and turning- Cams

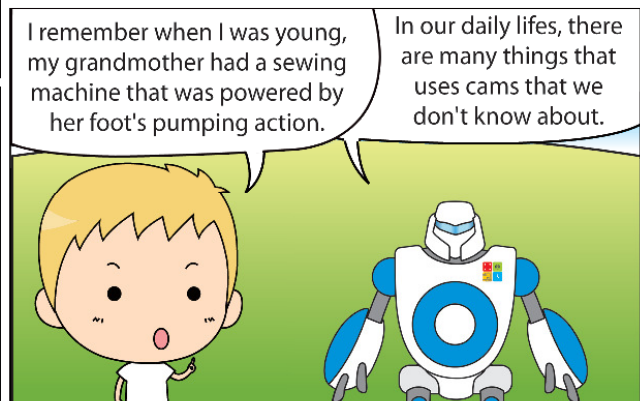
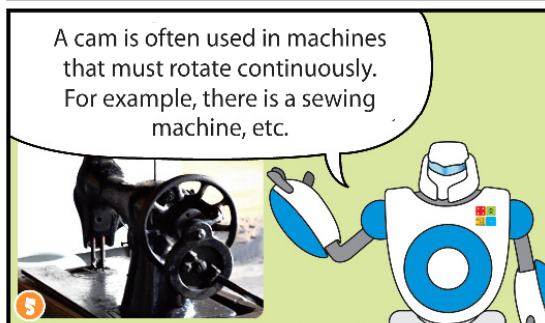
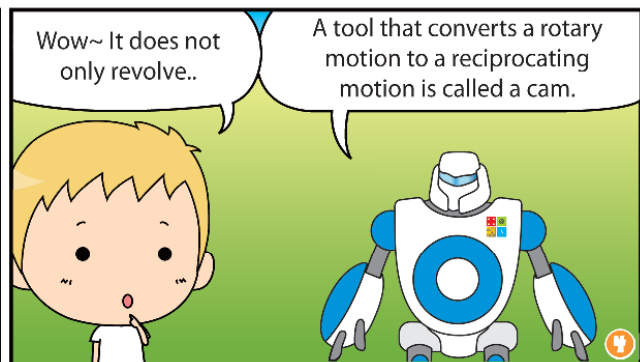
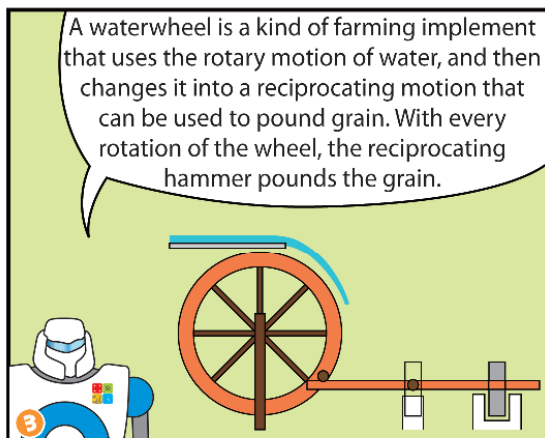
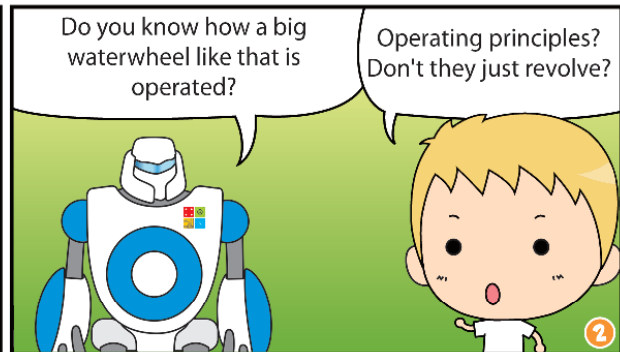
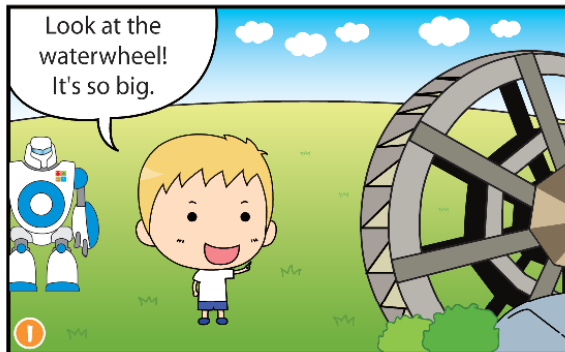

T Technology **M** Mathematics **STEM 5. You can't move anything without me! - Gear**

1 Huna, I can't move my bicycle.
Let me see... oh! It's got a broken gear!

2 A gear? I've heard of it before, but I don't know exactly what it is.
Gears are important units that deliver rotational energy for moving machine.

3 So, if my bike's gears are broken, no matter how hard I pedal, nothing will happen? right?
Gears are installed in many kinds of machinery. And gears are often used because of its incredible power delivery efficiency and long lifespan.

4 Yeah, If your bicycle can't transfer your power to the wheels, it can't move. And when a bicycle climbs a hill, did you know that if it is put in a lower gear, it will require even less power?

5 A bicycle connects a couple of gears in the front with the gears of the back wheel.
Ah~! Come to think of it, I heard my bicycle has 21(3x7) gears!!

6 This number of gear is different according to use. When you go an uphill road or a downhill road, if you control a gear well, It'll make the bicycle easier to pedal.
A car has gears, too. A car is equipped with a couple of gear in the transmission in order to make the best use of rotational power.

7 A gear of a bicycle or a car exist in order to make the best use of power. Then I'm going to ride my bicycle after repairing the gears.

 **Engineering Art** **Robot Making3-Golf Robot**

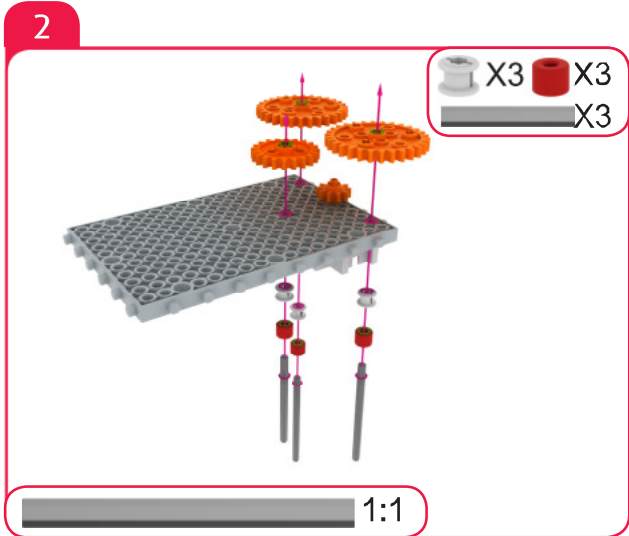
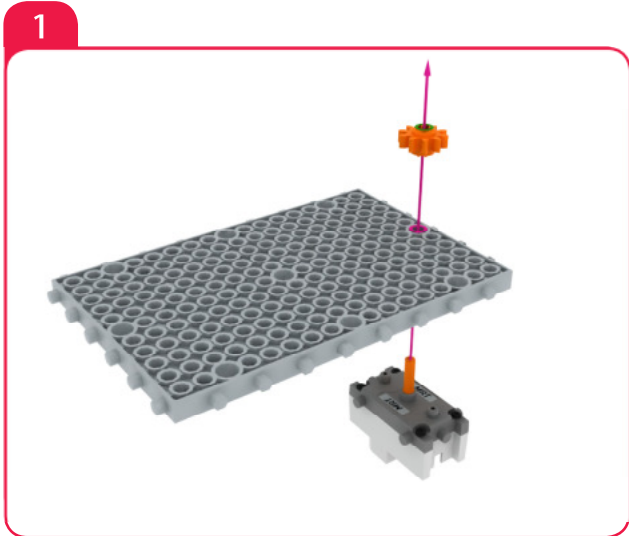

3

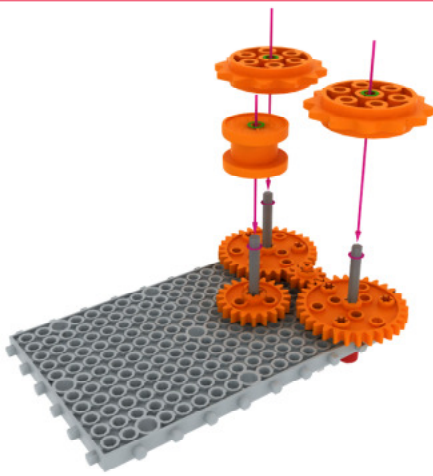

4

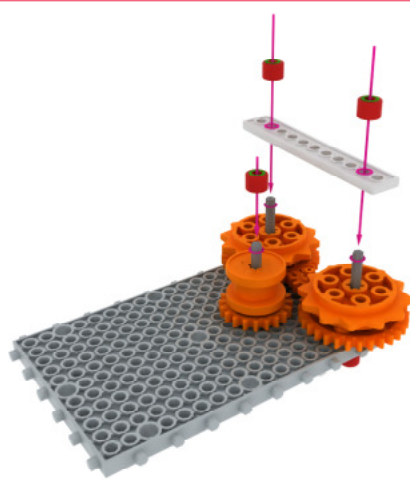

X3

5

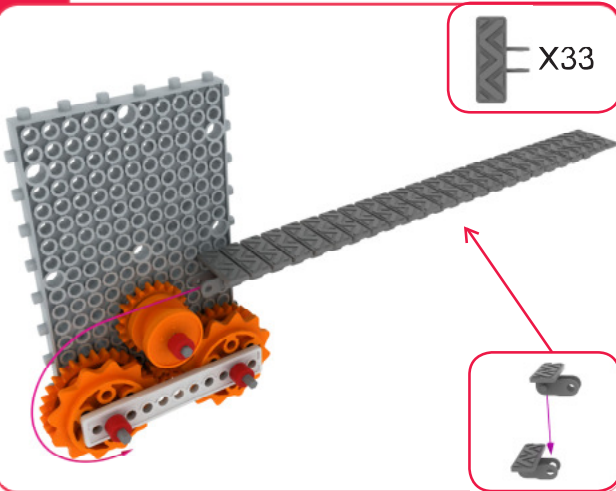

X33

6

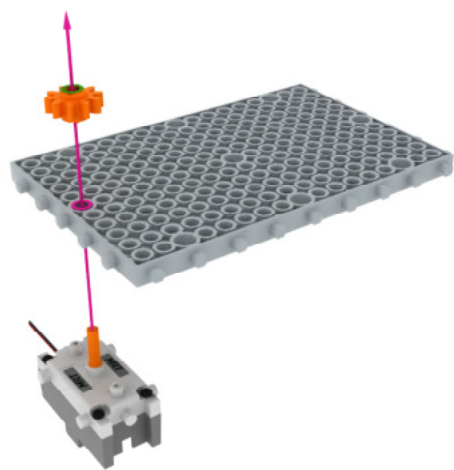

7

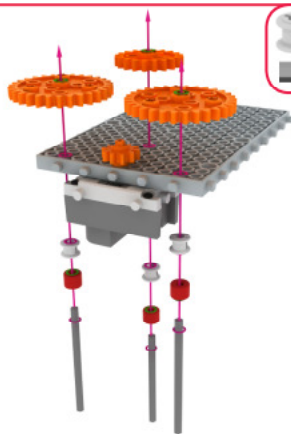

X3 X3 X3

1:1

8

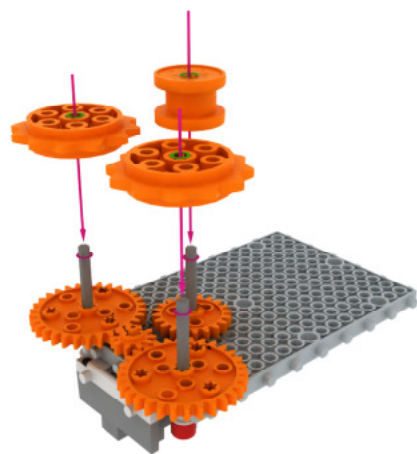

9

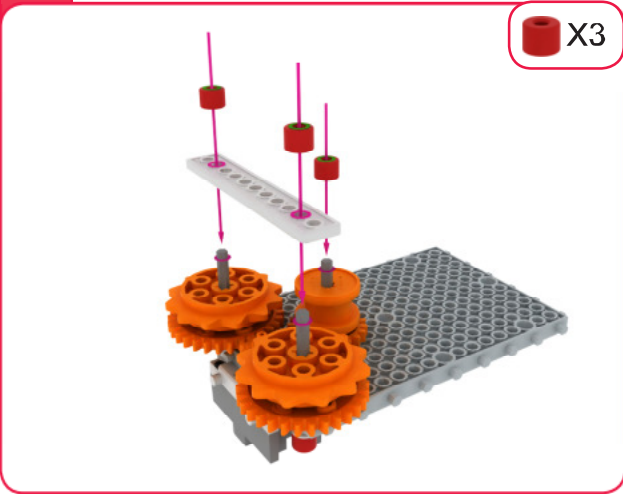

10

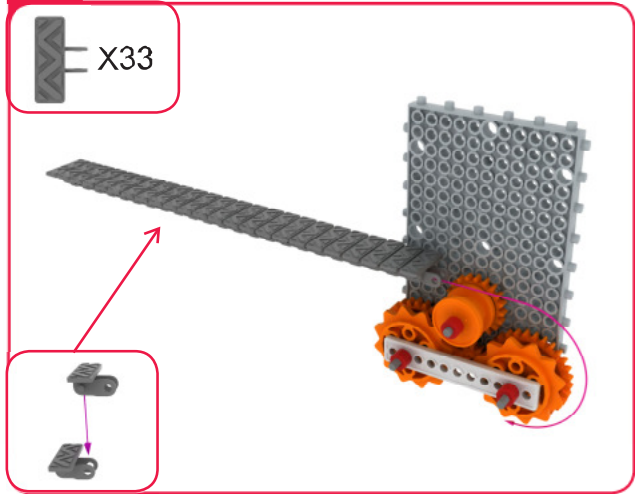

11

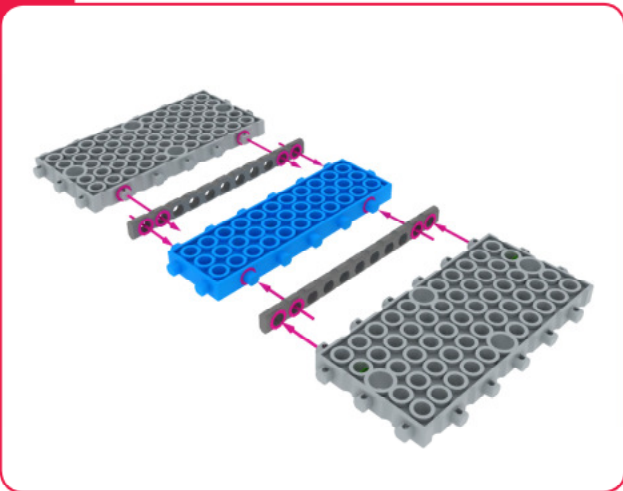

12

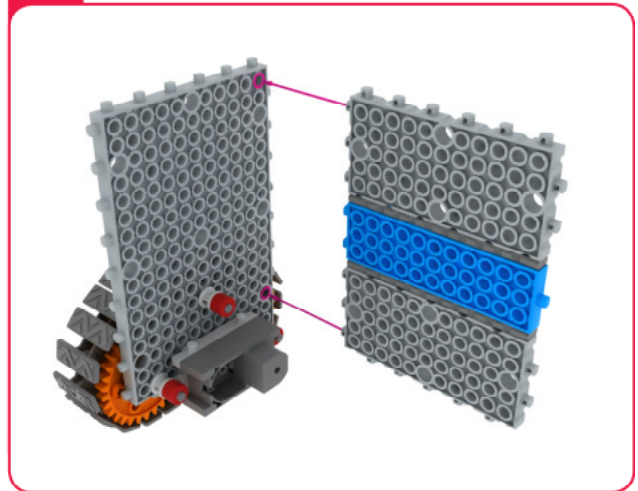

13

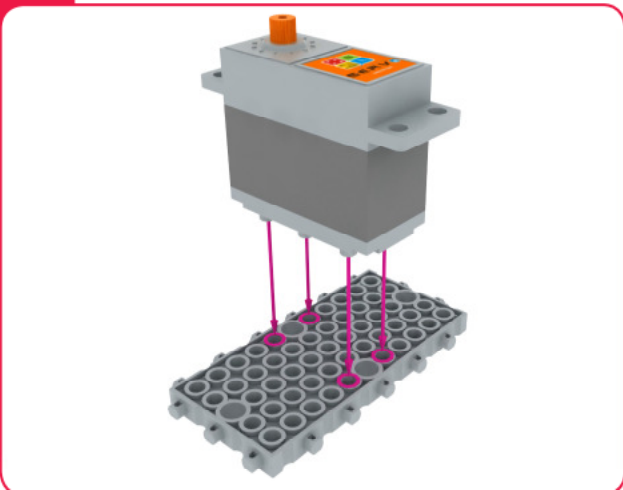

14

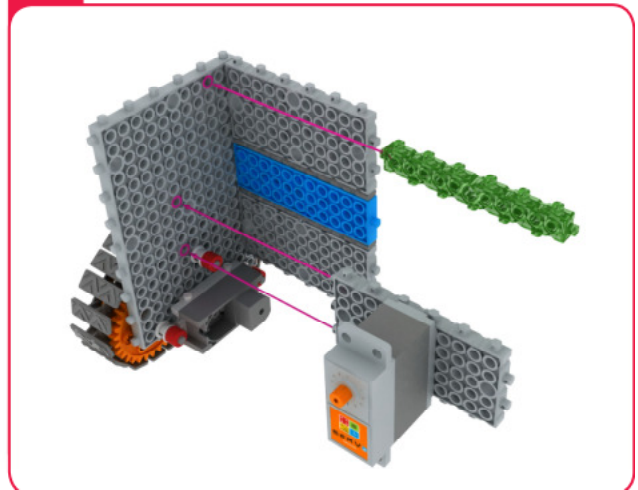

15

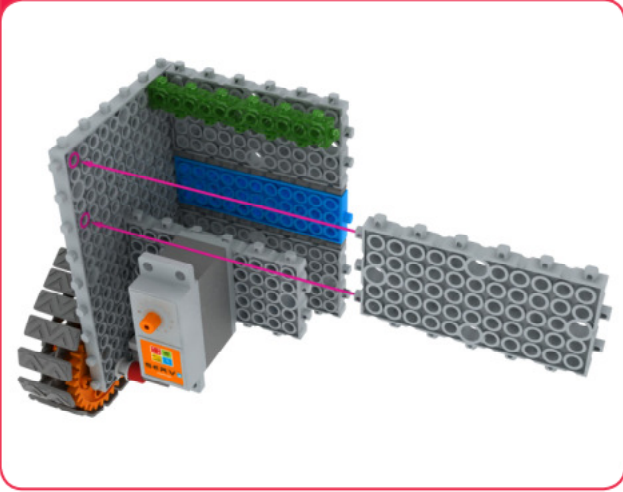

16

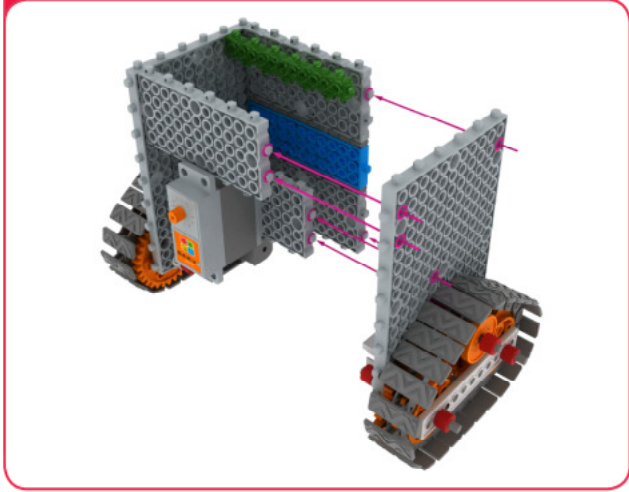

17

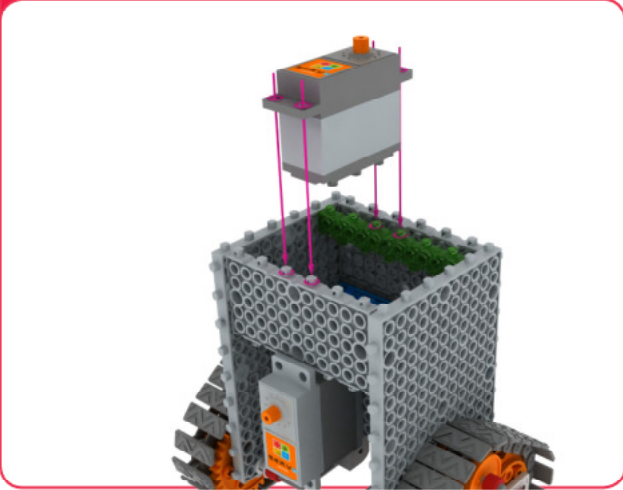

18

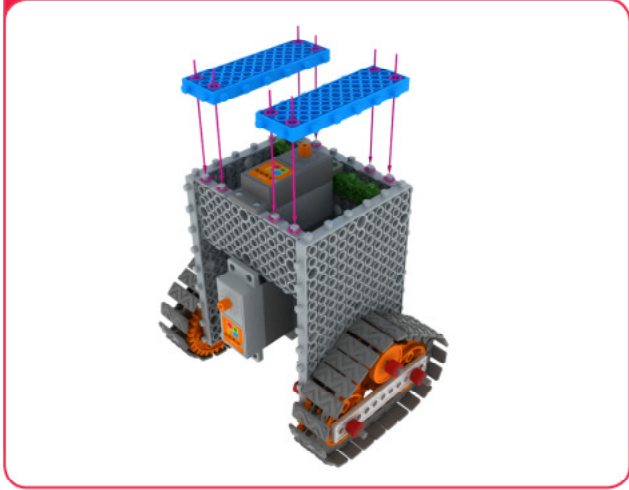

19

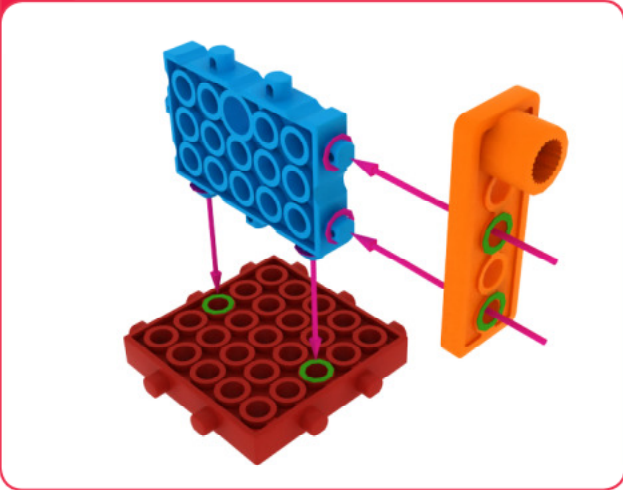

20

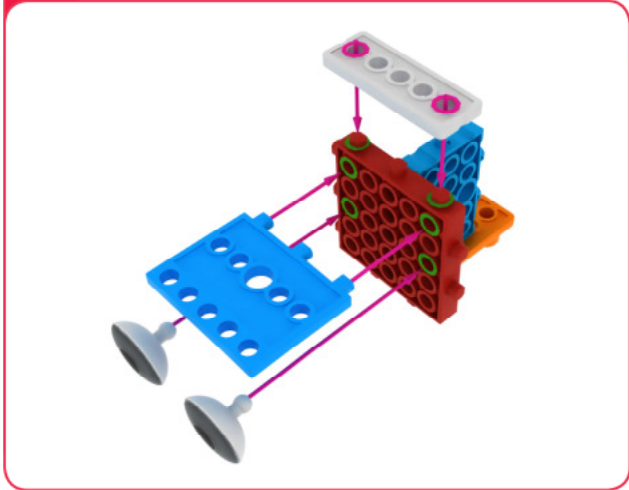

21

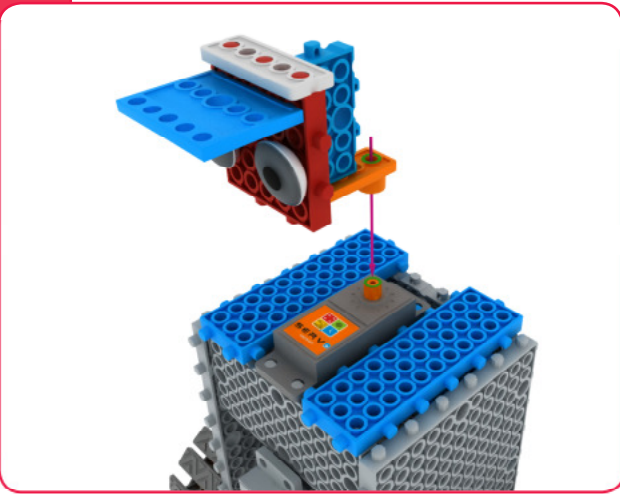

Servo Motor-Zero Point Adjustment

1. Connect the servo motor to the mainboard. You can write the program in the following way.

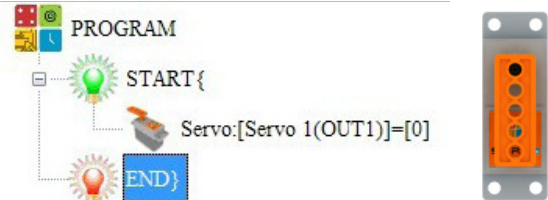

2. After downloading the program, power off and on again.
3. Fix servo motor horn to the servo motor with a small servo bolt as illustrated in the picture .

22

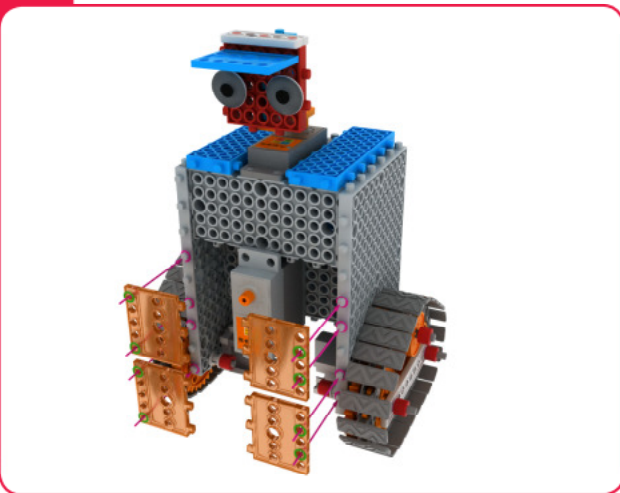

23

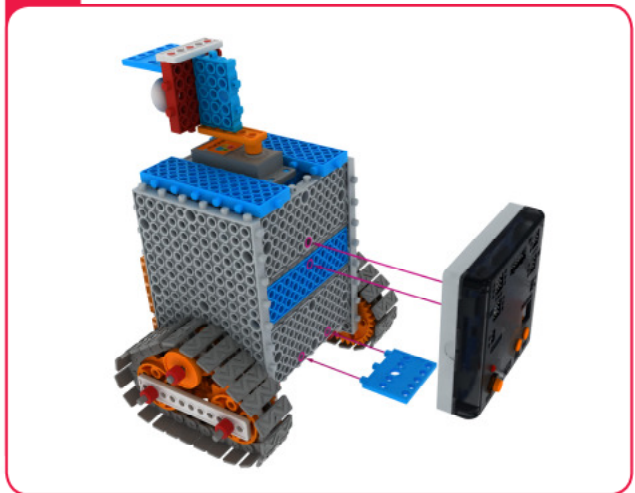

24

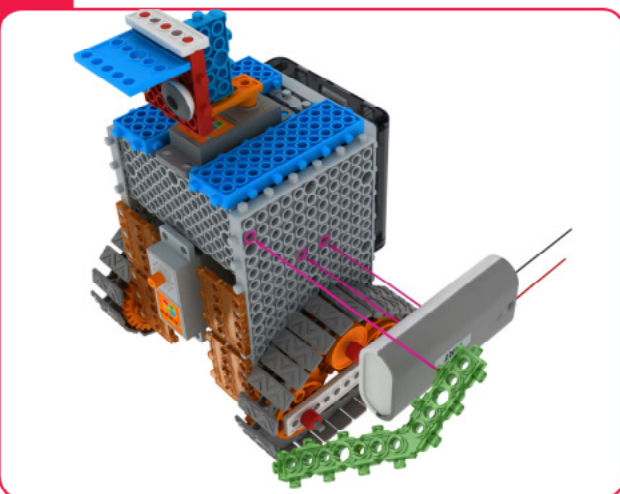

25

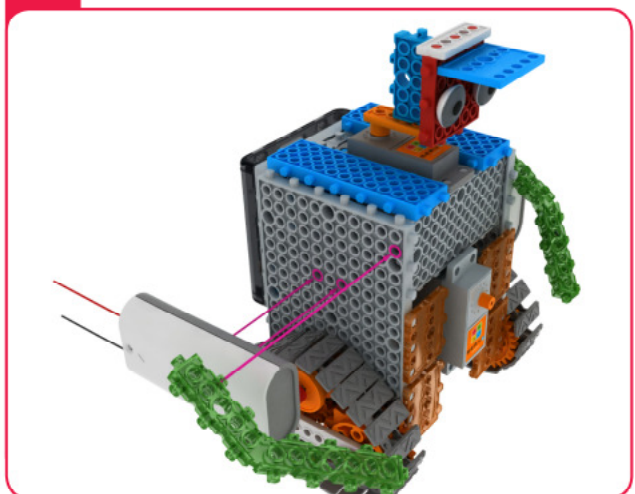

26

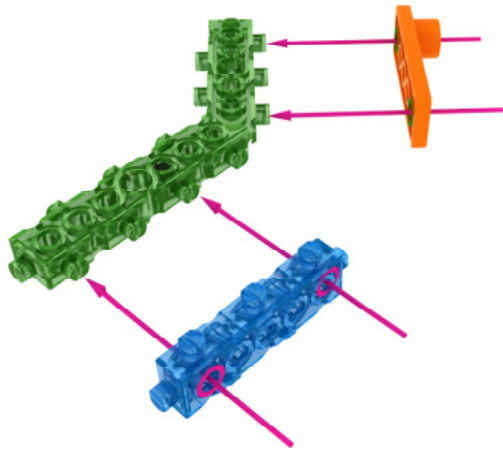

27

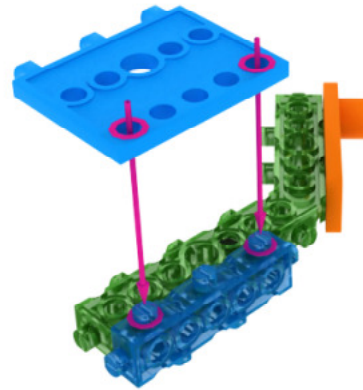

28



Servo Motor-Zero Point Adjustment

1. Connect the servo motor to the mainboard. You can write the program in the following way.

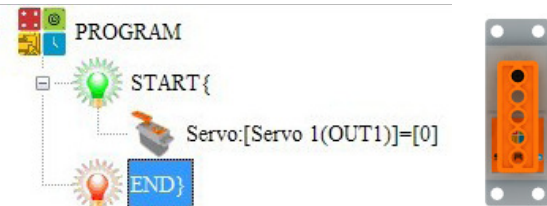

2. After downloading the program, power off and on again.
3. Fix servo motor horn to the servo motor with a small servo bolt as illustrated in the picture .

29

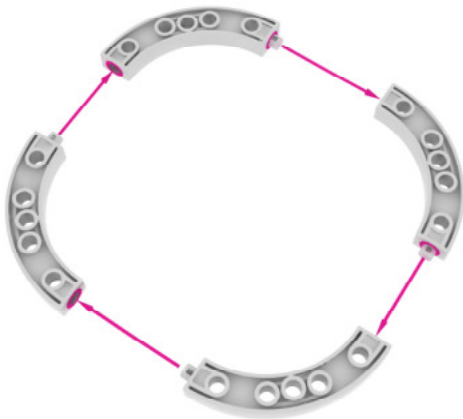

30

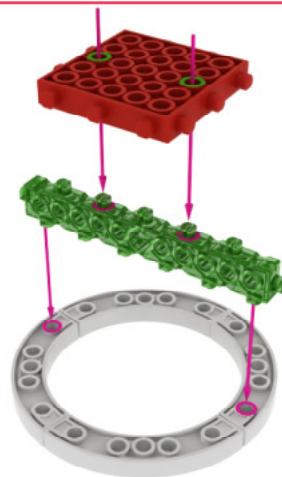

37-1

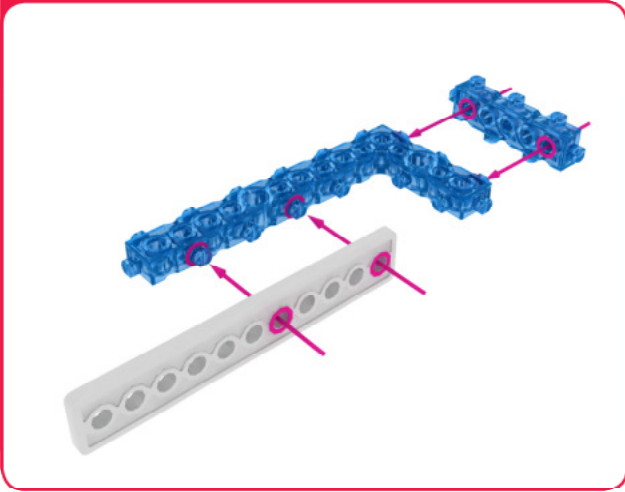

37-2

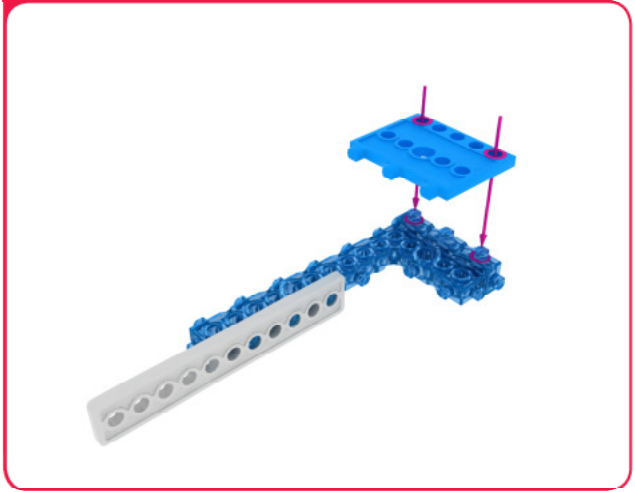

38

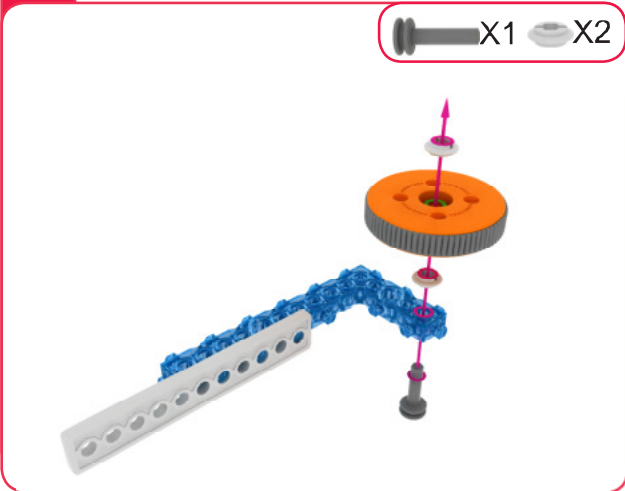

39

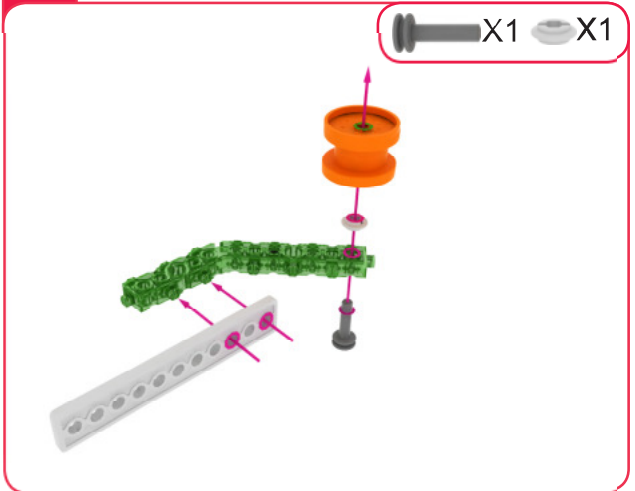

40-1

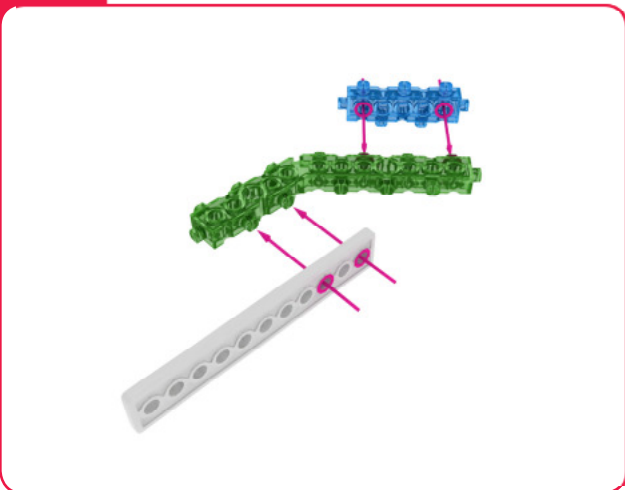

40-2

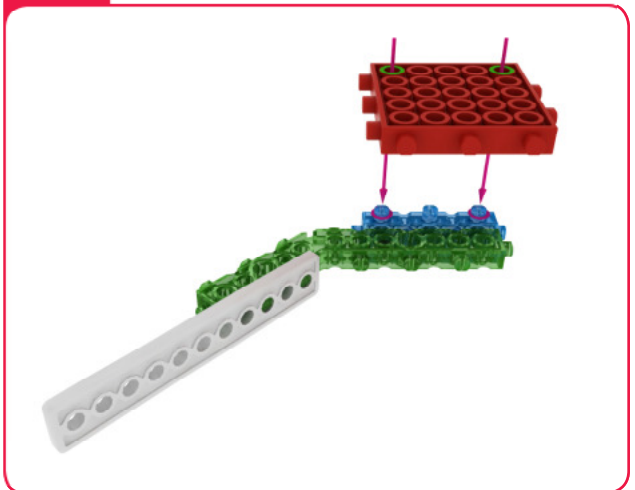

41



42



43



End





How to operate the Golf robot

Connecting the main board

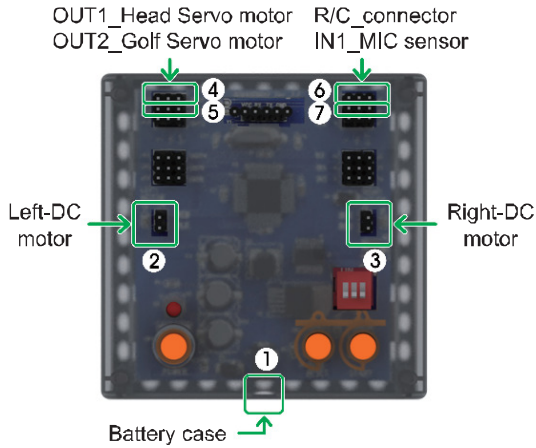

Connect in this order.

1. Connect Battery Cases to Power connector.
2. Connect Left-DC motor to Left-motor connector.
3. Connect Right-DC motor to Right-motor connector.
4. Connect Head Servo motor to OUT1 of OUTPUT connector.
5. Connect Golf Servo motor to OUT2 of OUTPUT connector.
6. Connect RC receiver board to R/C connector.
7. Connect MIC sensor to IN1 of INPUT connector.

Motion Pattern/Program

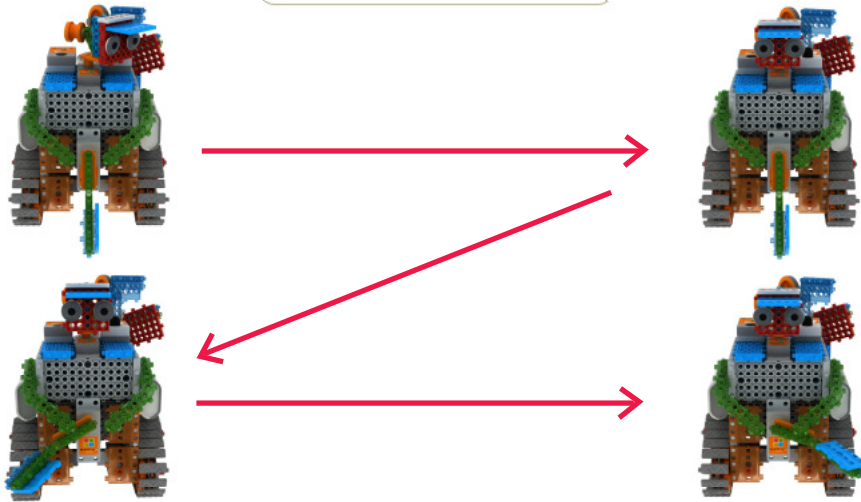

HINT1: After press F1 key and making some sound(applause), within 3 sec the robot will played putting.
(Mic sensor received the sounds as input signal.)

Program Download

1. Write the program.
2. Make sure Power / DC Motor connector and sensor's connector are well connected.
3. Check the power OFF state, then insert the download cable.
4. 'SAVE' and click the 'DOWNLOAD' button on the program window.
5. Turn on the power when 'DOWNLOAD' window opens. (Power ON)
6. Once the download is completed, remove the download cable and then turn the power off and on.
(Power OFF → Power ON)

Program Example

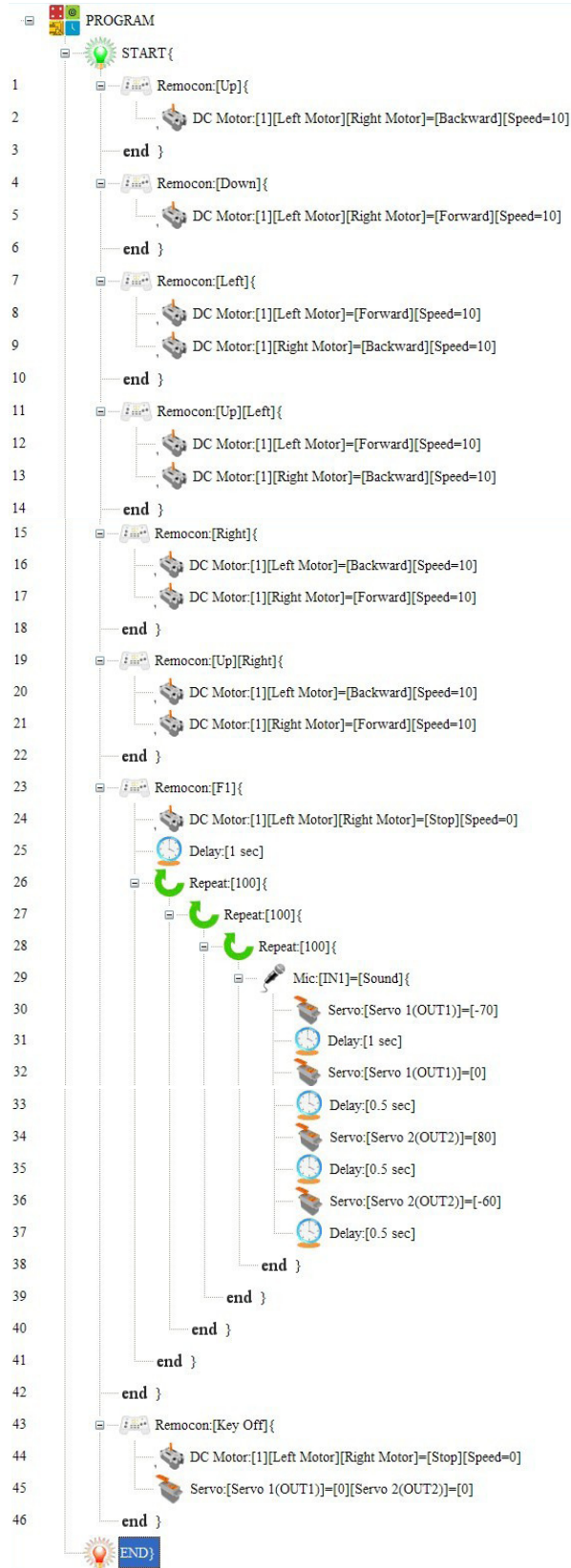

 **Art** *Let's play golf with your friends*

Beginner Course

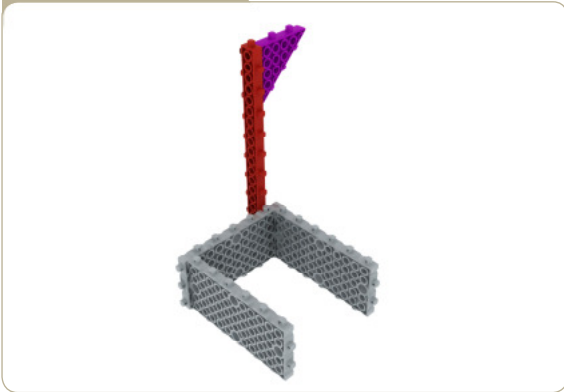

Advanced Course

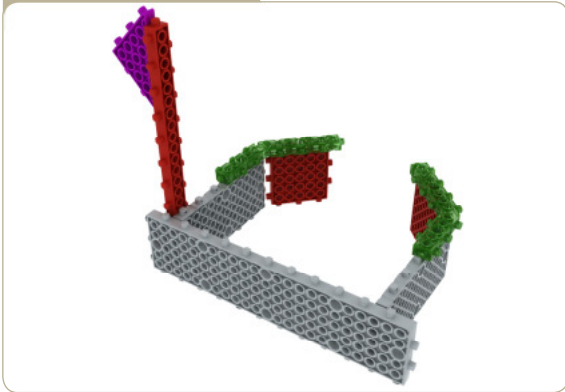

Hazard(obstacle)

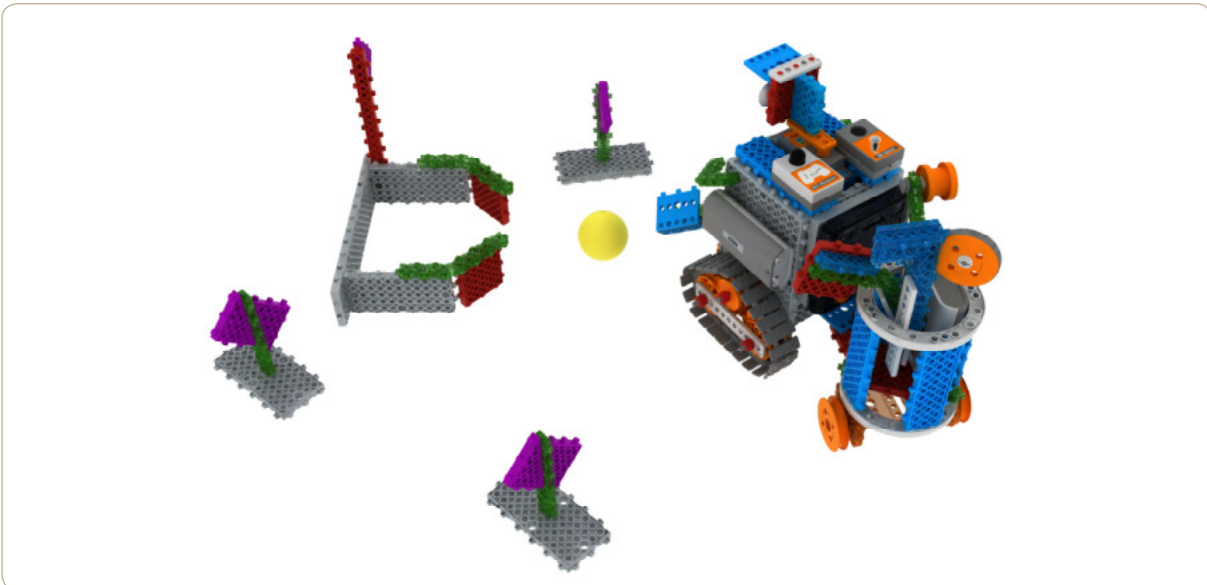
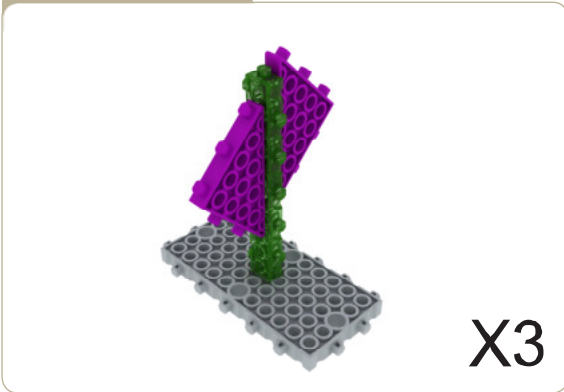

※ Make a holecup and obstacles with the rest blocks, Let's play golf with a ping-pong ball.



Technology
Engineering

STEM 6. The Ear of Robot—Sound Sensor (MIC)

Oh no, Huna! I bought a robot. But the robot is moving by itself!

Huh? oh! it might be broken?

Really? But it's brand new! How did it break?

Haha, just kidding! The manual says that the robot's movement were caused by the sound sensor.

Sobbing

Sound sensor? Does it cause movement when it perceives sound?

Yeah, that's right! Literally, the sound sensor perceives the sound and causes movement.

Does this sound make it move? That's pretty amazing!

Umm! It perceives sound by changing it into electric energy. This electric energy gives the robot ability to move.

Wow, I think the sound sensors can be very useful for a lot of things. Can it even perceive me speaking or the clapping of my hands?

Of course! These days, sound sensors are even used to treat snoring people.

A cure for snoring!!

Yeah! As soon as the sound sensor pajamas perceive snoring, it inflates.

That's amazing! I'll make other robots that will use sound sensors to activate and do creative new things!



Science

STEM 7. Oh my God, Hot!
Thermal energy

Panel 1: A boy with blonde hair sits at a table with a plate of blue ice cubes. A speech bubble says: "Ice melts quickly in the summer... But, why does ice change to water?"

Panel 2: A blue and white robot with a circular logo on its chest responds: "Because of the thermal energy."

Panel 3: The robot explains: "It can occur in two ways. First, when objects are heated. Second, when objects emit heat!"

Panel 4: The boy asks: "Because ice accepts thermal energy from air, it becomes water." The robot replies: "Because water emit a thermal energy, it becomes ice."

Panel 5: The robot asks: "Peter~ Let me ask you a question." Below, a kettle is shown with steam rising from it. A speech bubble says: "When water boils, why does it generate steam?"

Panel 6: The boy explains: "Because water accepts thermal energy. The reason why beads of water form after it was boiled is because the steam lost it's heat energy."



Technology
Engineering

Robot Making4-Bulldozer



1

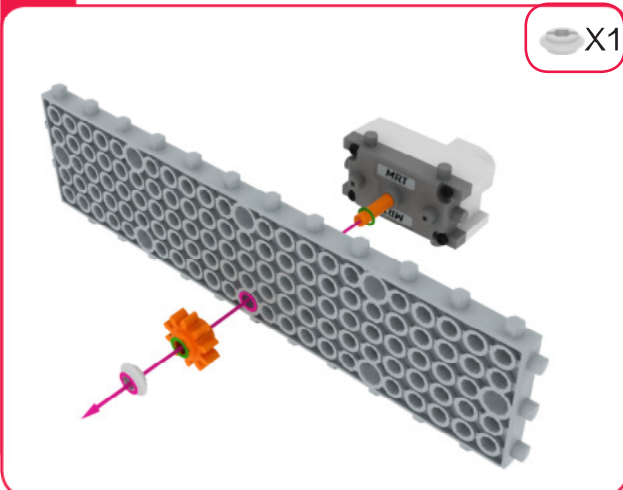

2

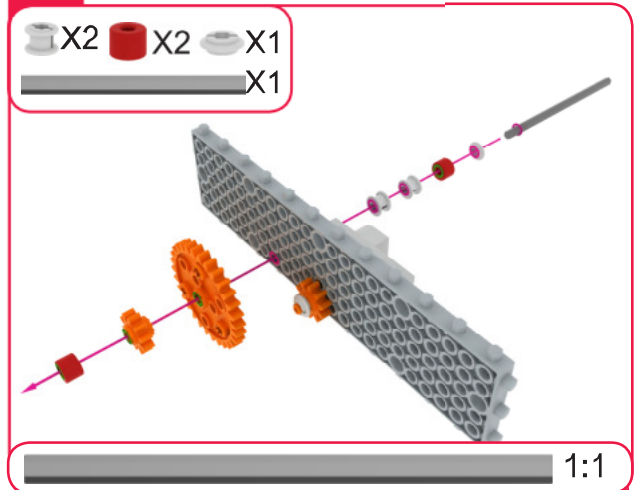

Advanced Level

3

X1 X2 X1

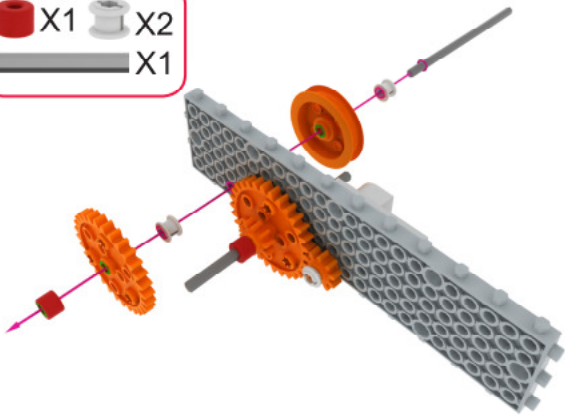

1:1

4

X1 X1 X1 X1

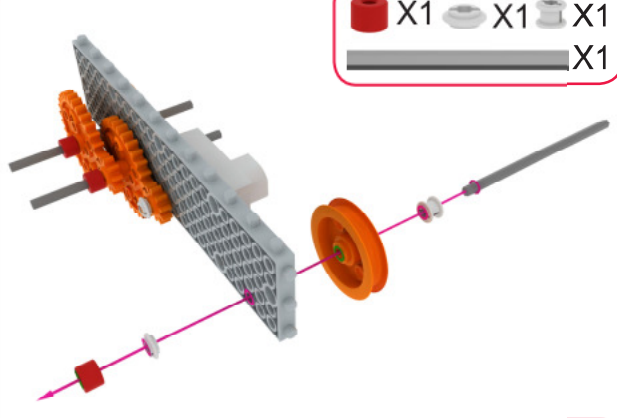

1:1

5

X2 X1

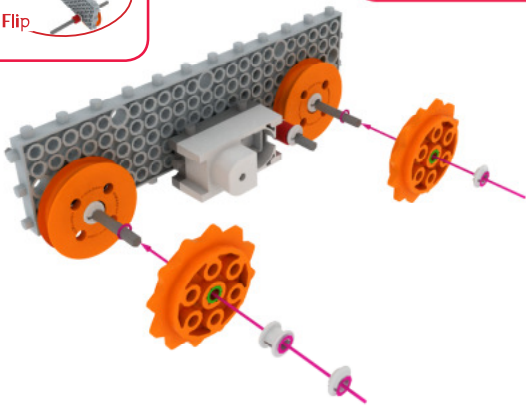
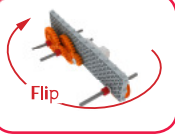

6

X2

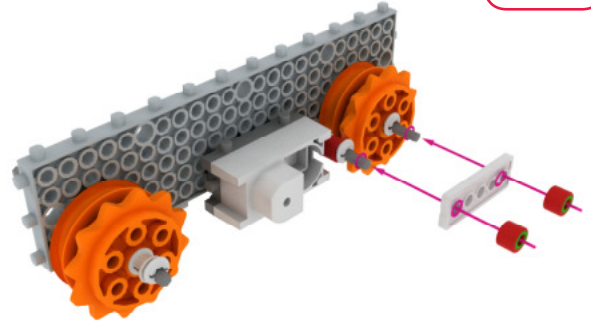

7

X1

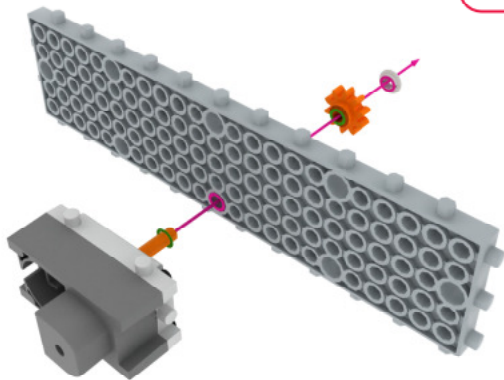

8

X2 X1 X2 X1

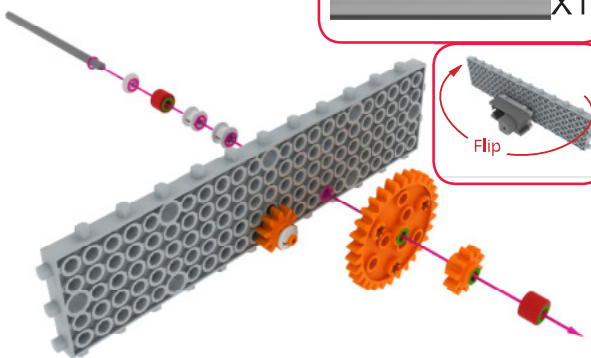
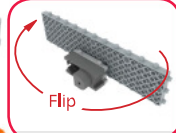

1:1

15

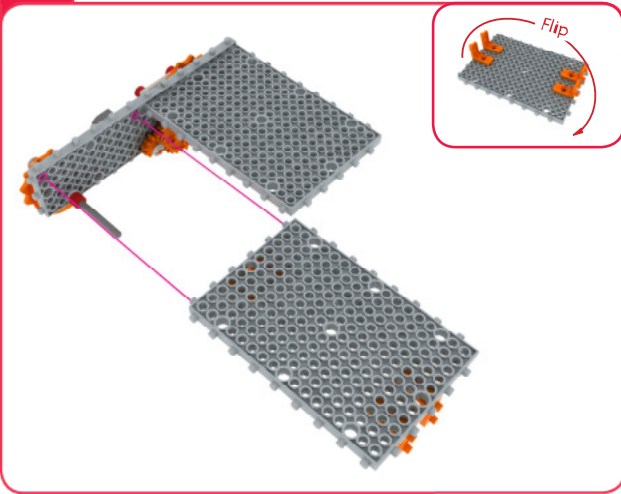

16

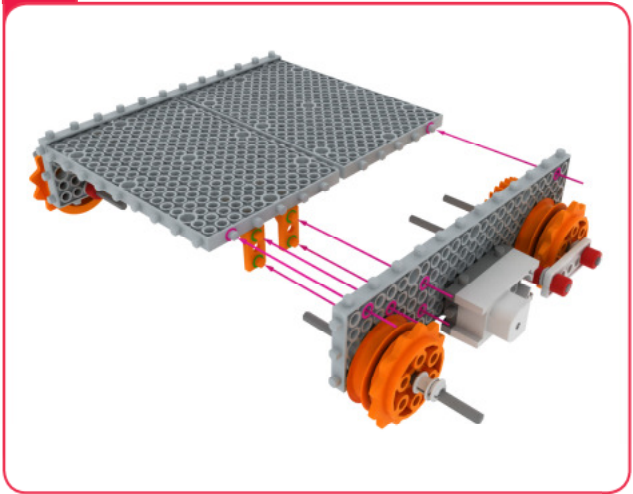

17

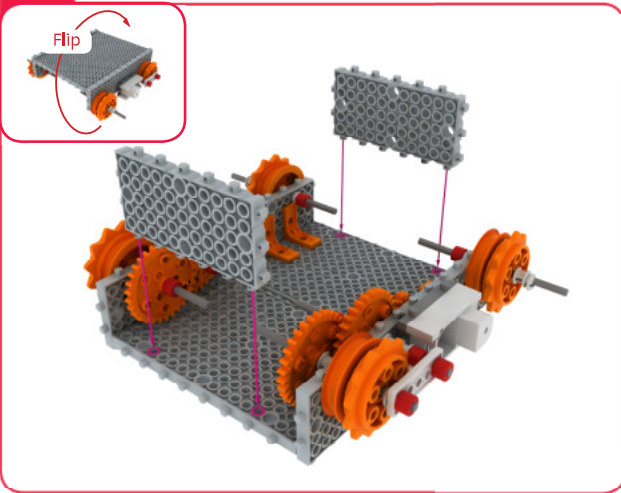

18

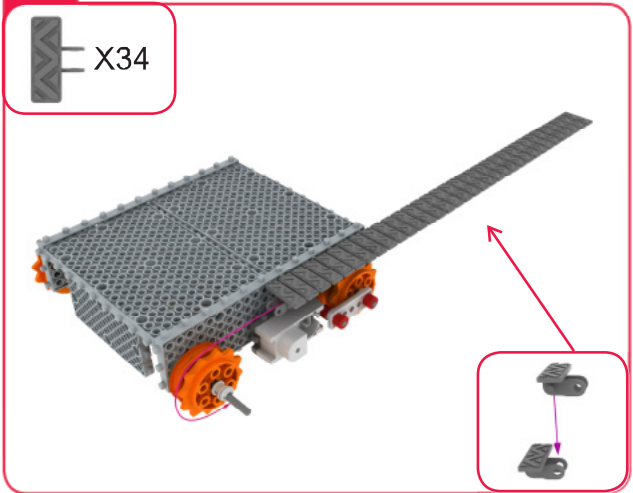

19

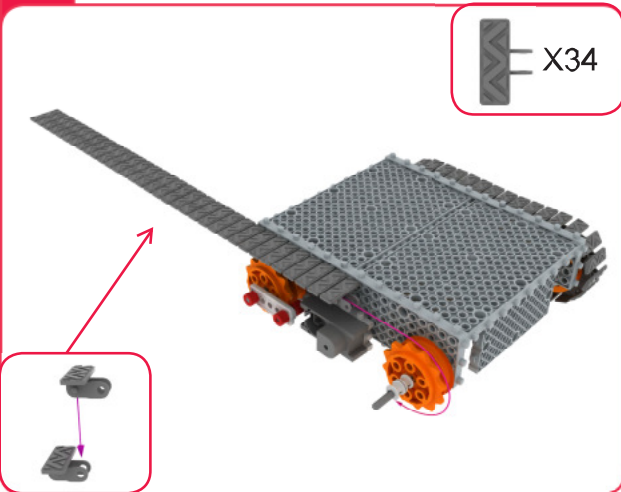

20

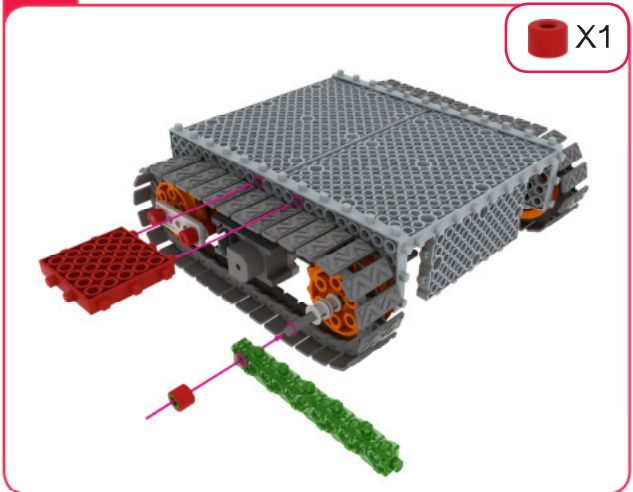

27

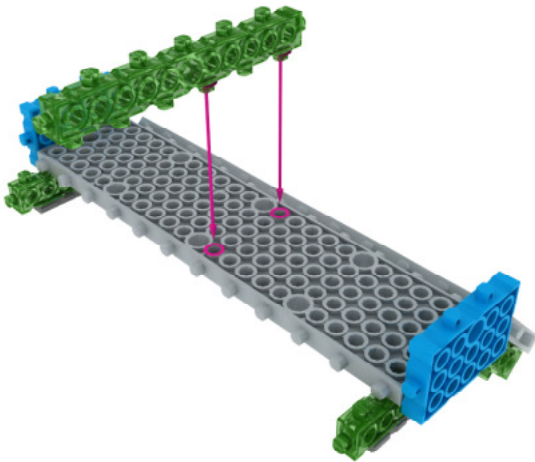



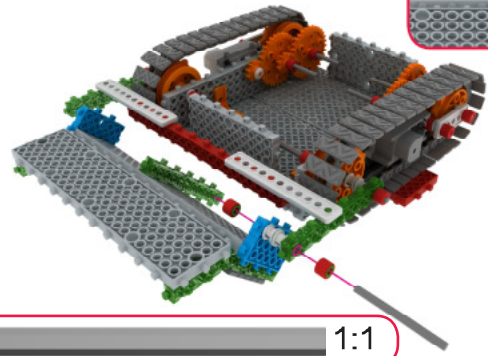

28

-  X2
-  X2
-  X1



29

-  X2
-  X1
-  X1
-  X1

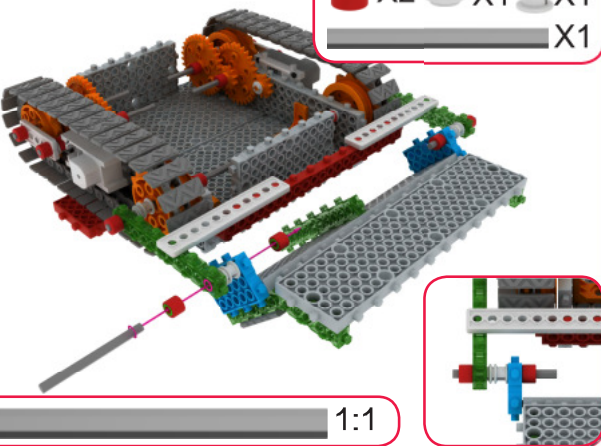

30

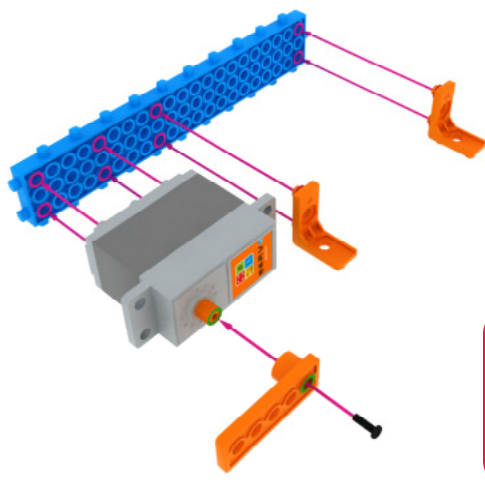

Servo Motor-Zero Point Adjustment

1. Connect the servo motor to the mainboard. You can write the program in the following way.

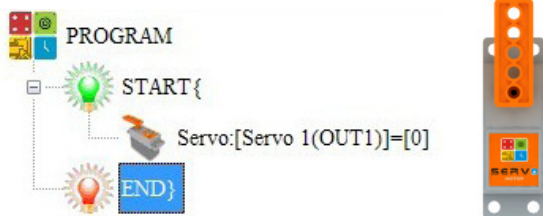

2. After downloading the program, power off and on again.
3. Fix servo motor horn to the servo motor with a small servo bolt as illustrated in the picture .

31

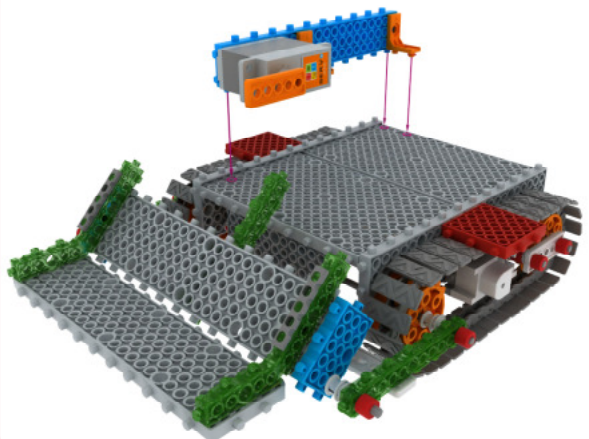

32

X1 X1

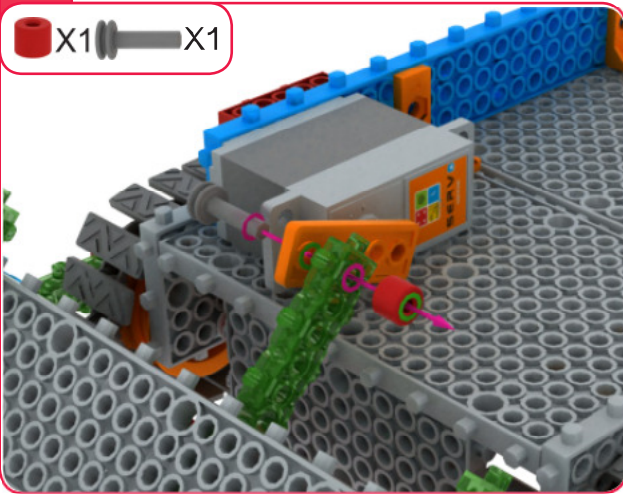

33

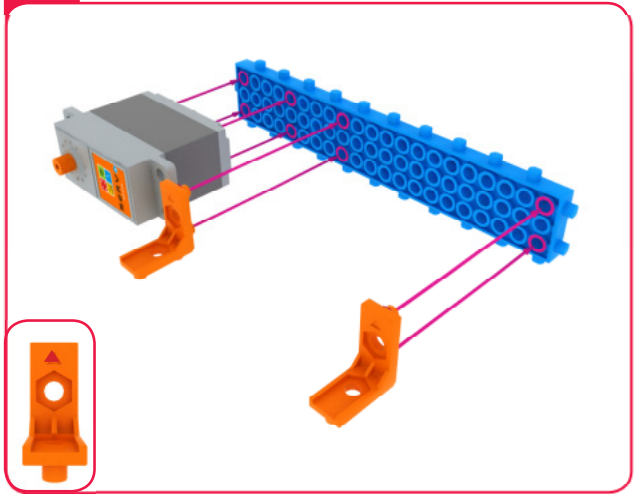

34

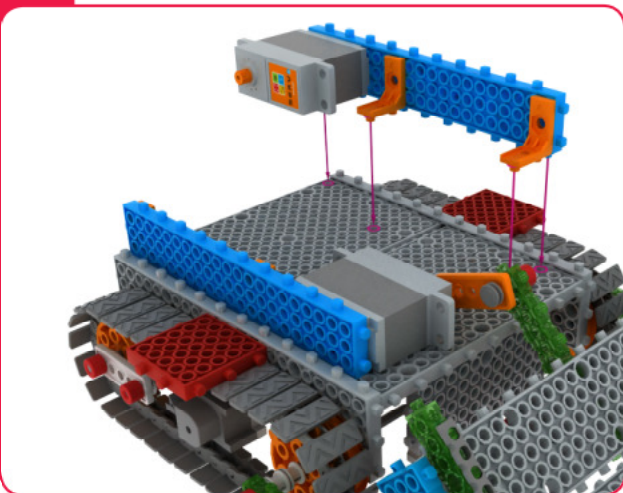

35

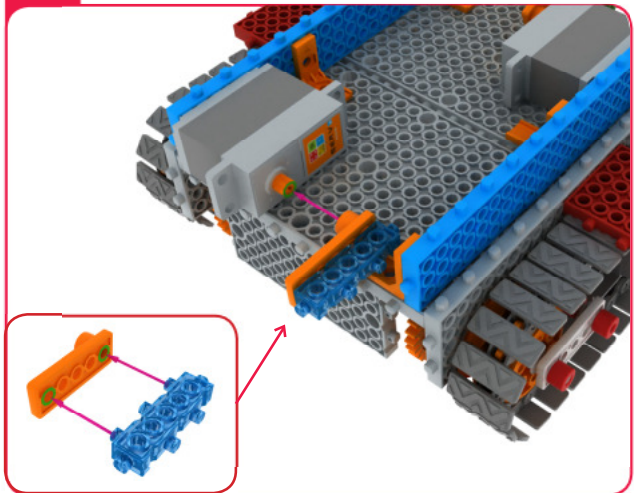

Servo Motor-Zero Point Adjustment

1. Connect the servo motor to the mainboard. You can write the program in the following way.

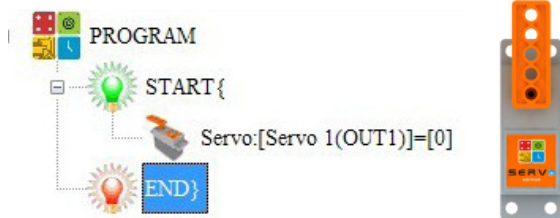

2. After downloading the program, power off and on again.
3. Fix servo motor horn to the servo motor with a small servo bolt as illustrated in the picture .

36

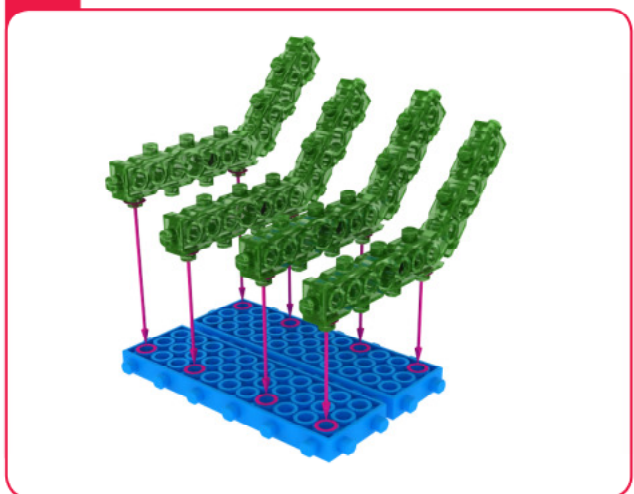

37

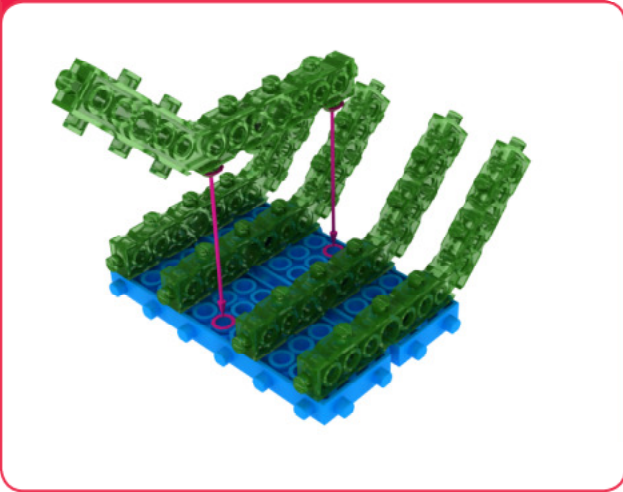

38

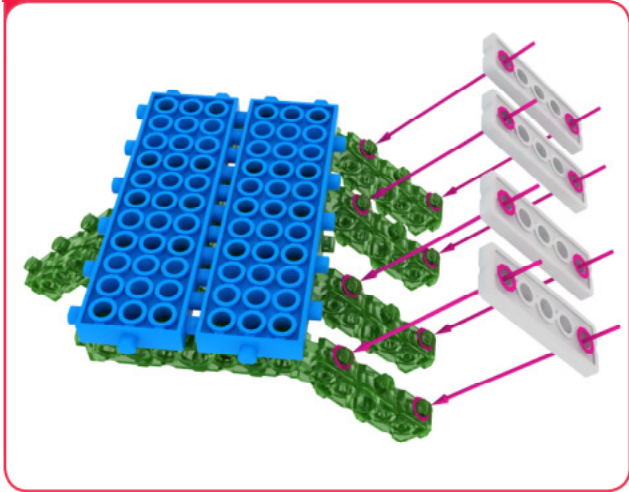

39

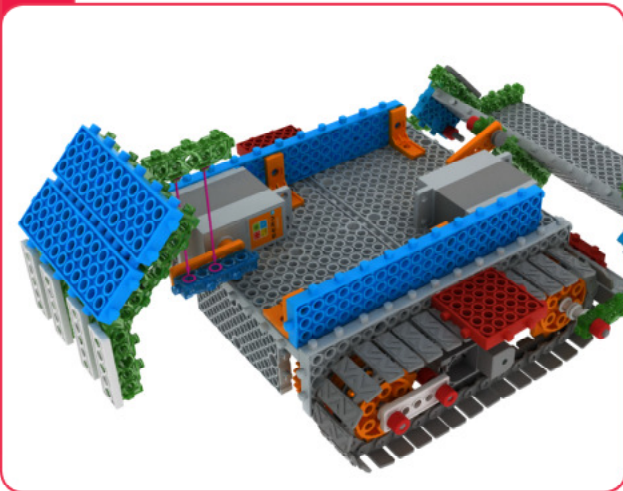

40

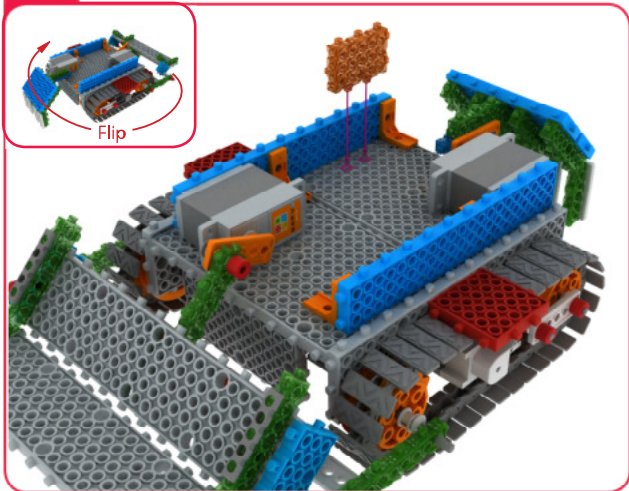

41

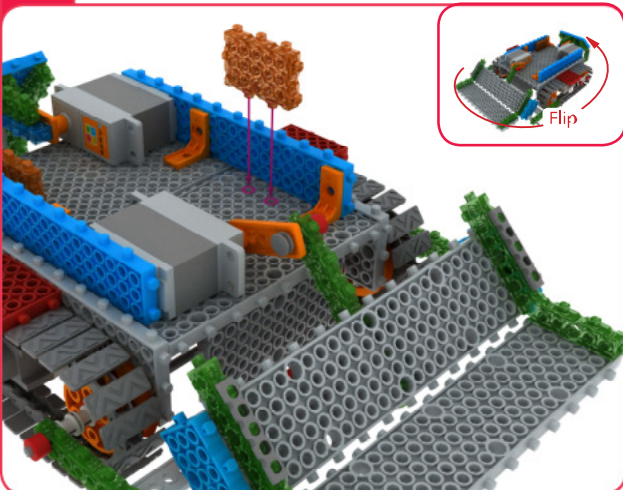

42

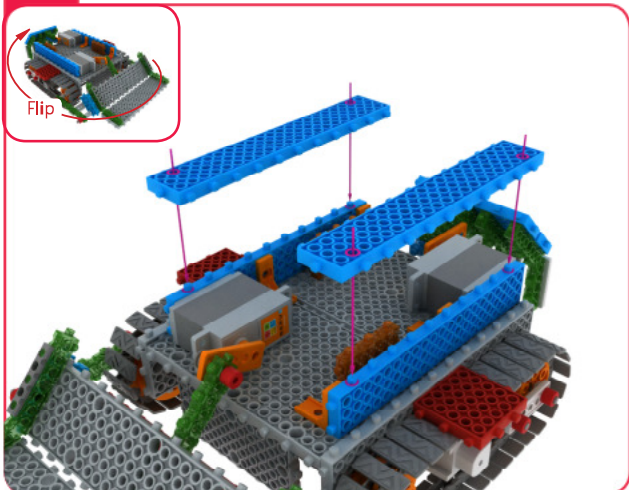

43

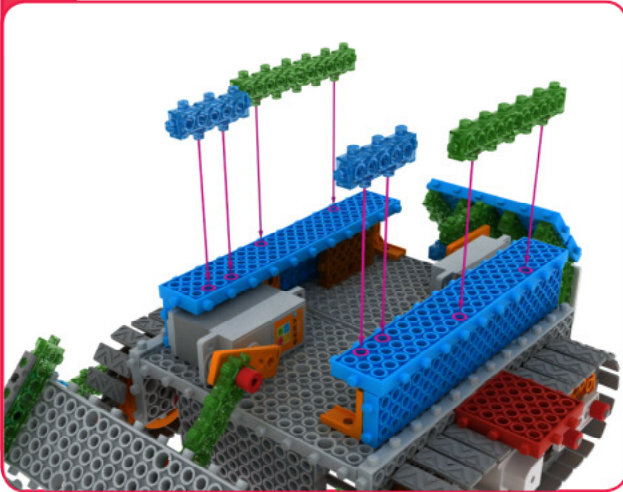

44

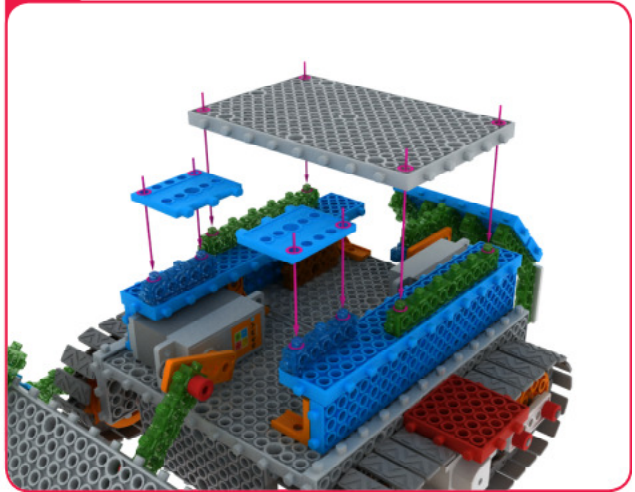

45

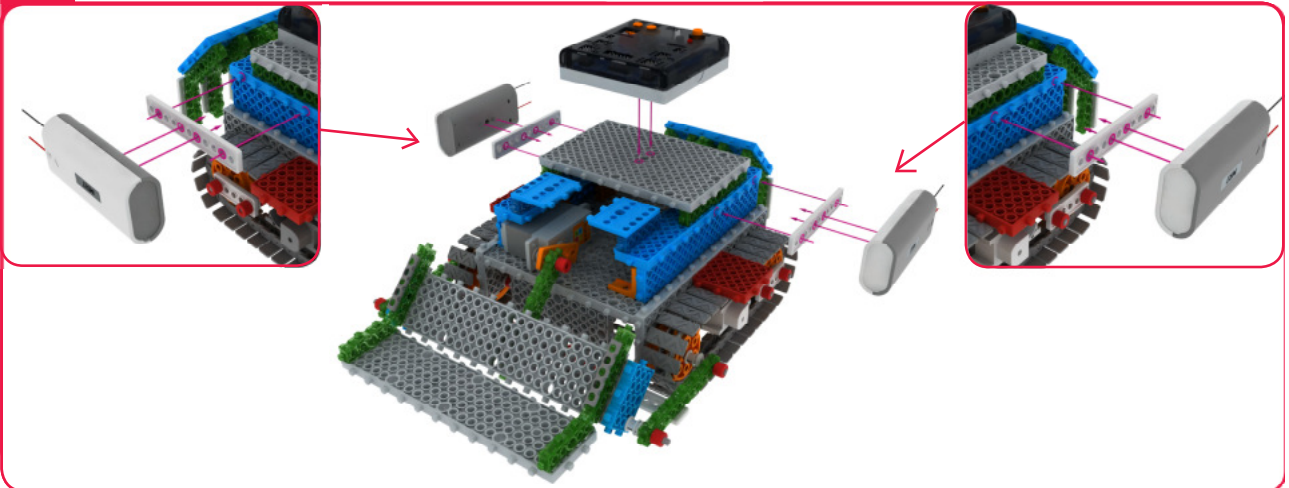

46

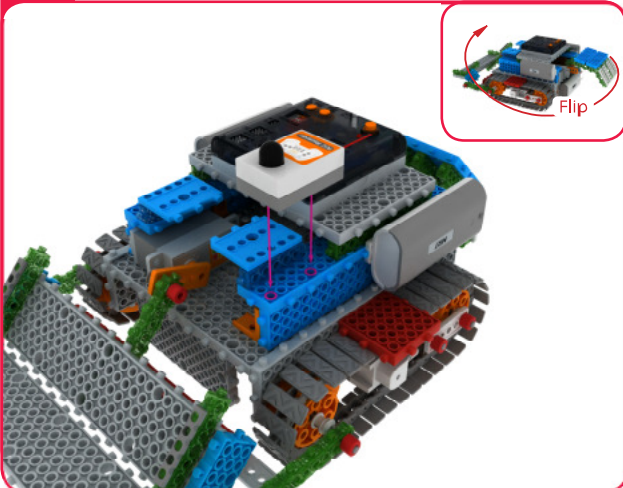

End

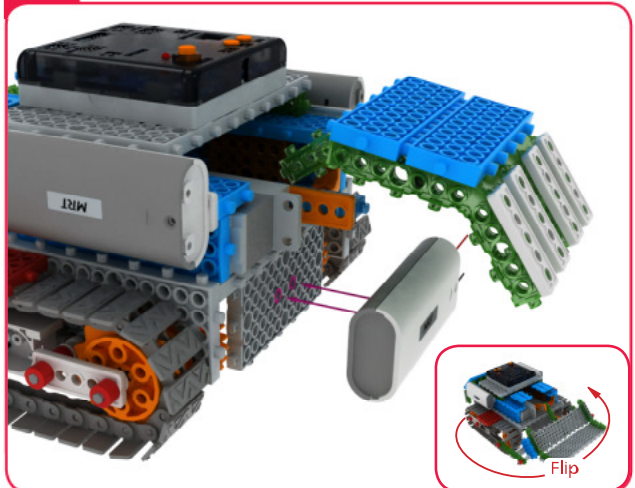



How to operate the Bulldozer

Connecting the main board

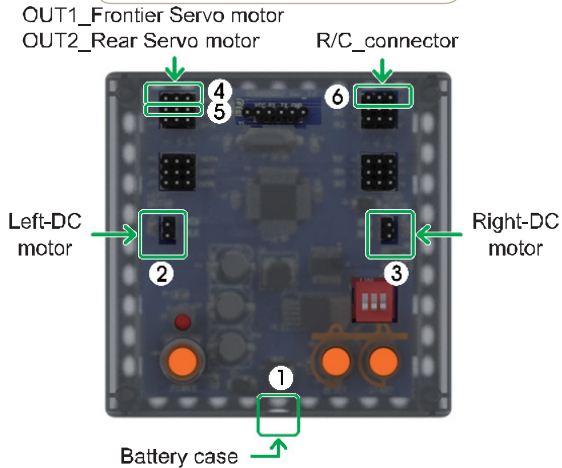

Connect in this order.

1. Connect Battery Cases to Power connector.
2. Connect Left-DC motor to Left-motor connector.
3. Connect Right-DC motor to Right-motor connector.
4. Connect Frontier Servo motor to OUT1 of OUTPUT connector.
5. Connect Rear Servo motor to OUT2 of OUTPUT connector.
6. Connect RC receiver board to R/C connector.

Motion Pattern/Program

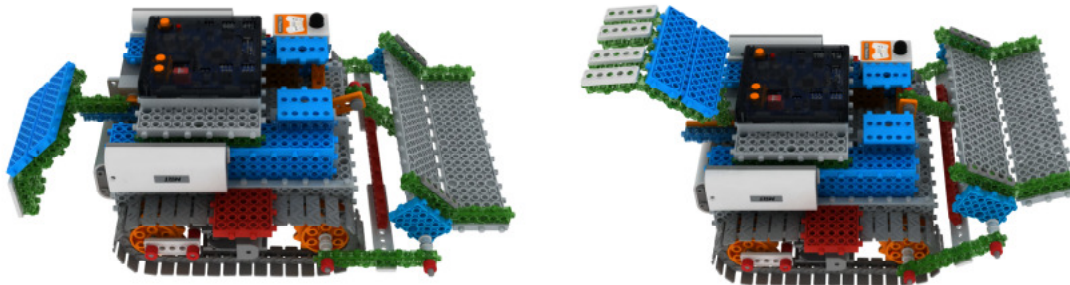

HINT1 : F1&F4 key controls the frontier blade.

HINT2 : F3&F6 key controls the rear blade.

Program Download

1. Write the program.
2. Make sure Power / DC Motor connector and sensor's connector are well connected.
3. Check the power OFF state, then insert the download cable.
4. 'SAVE' and click the 'DOWNLOAD' button on the program window.
5. Turn on the power when 'DOWNLOAD' window opens. (Power ON)
6. Once the download is completed, remove the download cable and then turn the power off and on.
(Power OFF → Power ON)

Program Example

```

PROGRAM
START {
1  Remocon:[Up]{
2      DC Motor:[1][Left Motor][Right Motor]=[Forward][Speed=10]
3  }
4  Remocon:[Down]{
5      DC Motor:[1][Left Motor][Right Motor]=[Stop][Speed=0]
6  }
7  Remocon:[Left]{
8      DC Motor:[1][Left Motor]=[Backward][Speed=10]
9      DC Motor:[1][Right Motor]=[Forward][Speed=10]
10 }
11 Remocon:[Up][Left]{
12     DC Motor:[1][Left Motor]=[Stop][Speed=0]
13     DC Motor:[1][Right Motor]=[Forward][Speed=10]
14 }
15 Remocon:[Right]{
16     DC Motor:[1][Left Motor]=[Forward][Speed=10]
17     DC Motor:[1][Right Motor]=[Backward][Speed=10]
18 }
19 Remocon:[Up][Right]{
20     DC Motor:[1][Left Motor]=[Forward][Speed=10]
21     DC Motor:[1][Right Motor]=[Stop][Speed=0]
22 }
23 Remocon:[F1]{
24     Servo:[Servo 1(OUT1)]=[60]
25 }
26 Remocon:[F4]{
27     Servo:[Servo 1(OUT1)]=[0]
28 }
29 Remocon:[F3]{
30     Servo:[Servo 2(OUT2)]=[60]
31 }
32 Remocon:[F6]{
33     Servo:[Servo 2(OUT2)]=[0]
34 }
35 Remocon:[Key Off]{
36     DC Motor:[1][Left Motor][Right Motor]=[Stop][Speed=0]
37 }
END}
    
```

Art
Mathematics *Enjoy various games with bulldozer robot*

Game1 : Collecting blocks



※ Who can collect more blocks will be the winner.

Game2 : Pushing out blocks

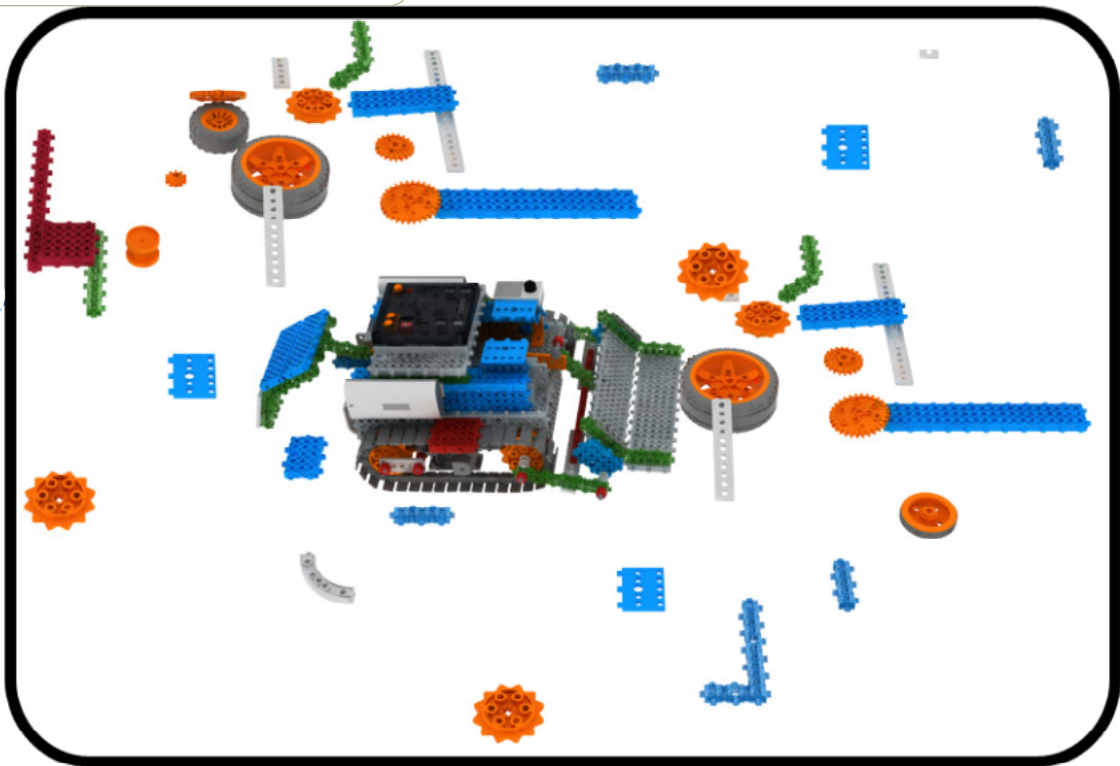







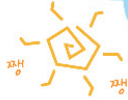
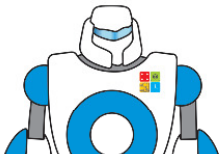
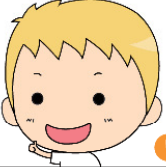

※ Who can push out more blocks in limited time will be the winner.

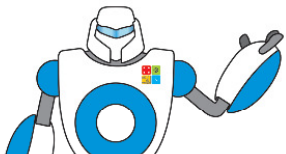
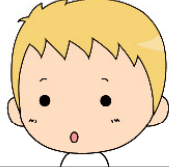
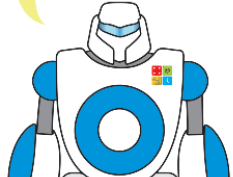
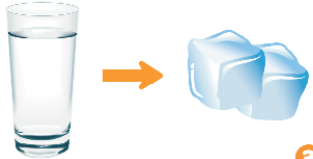

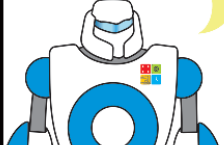
Science

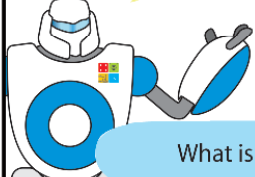
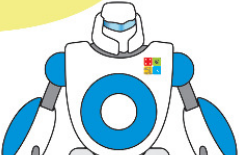
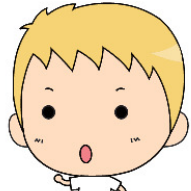
STEM 8. How can we use thermal energy?

<p>It's so hot because of the summer!!</p>    <p>In summer, ice is best!!</p>  <p>1</p>	<p>Yeah, ice is great~ Did you know that is made from using a thermal energy?</p>    <p>Really? How does cold ice use a warm thermal energy?</p> <p>2</p>	
<p>Just by emitting heat! Water becomes ice because it emits its heat to colder places.</p>  <p>So, if you want to change a liquid such as water to a solid object such as ice, you need to make it emit heat, then it will start coagulating.</p>  <p>3</p>	<p>Does the process of melting ice use thermal energy as well?</p>  <p>4</p>	
<p>Right! In warm places, ice melts because it accepts heat from warmer places. To go from a solid state to a liquid state is called melting.</p>  <p>5</p>	<p>It's amazing! Is there something else?</p>  <p>6</p>	<p>Of course! The gas in the air can become solid as well. In this case, it also emits heat.</p>  <p>What is that?</p>
<p>That is 'sublimation'. When a gas changes from a gas to a solid state, it is called sublimation.</p>  <p>Then, of course, gas can change to a liquid state as well. It can even change from liquid to gas.</p>  <p>8</p>	<p>When an object moves from a gas-like state to liquid state with the emission of heat, it is called liquefaction. To go from a liquid to a gas-like state is called evaporation. When water boils, the steam that moves into the air is evaporation.</p>  <p>9</p>	

S Science **STEM 9. I feel a twingel! My body is trembling—Electric Energy**

1 Hey, Huna!! It's so dark. The electricity is out. Let's go find a candle.

2 How could we have lived without the electricity that makes light shine brightly for us. It's not the electricity that gives us light, but light energy from the light bulb.

3 Wow! Are you saying that electric energy finally changes into light energy! Right! This electric energy can be seen as the power electricity possesses.

4 In that case, how do they generate electric energy?

5 Electricity is generated in a power plants.

6 There are several kinds of power plants. Hydroelectric power plants using water, wind power plants using wind, etc..

7 Fun facts?? Can you tell me more? Electric energy can be changed into various kind of energy! For instance ,electric energy can change into light energy using a light bulb.

8 Then... electric energy is magic! Amazing, right? Let's look for other devices that change electric energy into other kinds of energy.



Engineering
Art

Robot Making5-Mountain Motor bike



1

X1 X1

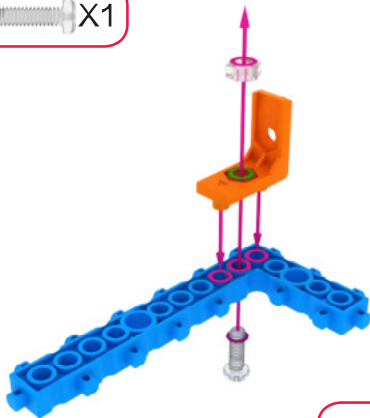

1:1

2

X1 X1

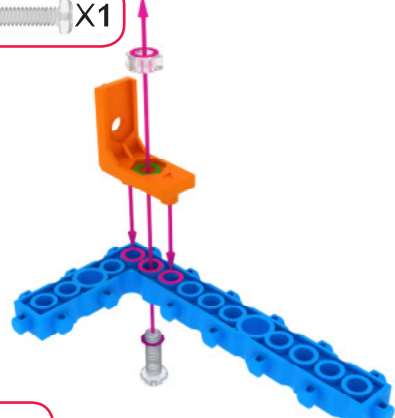

1:1

3

- X2
- X2

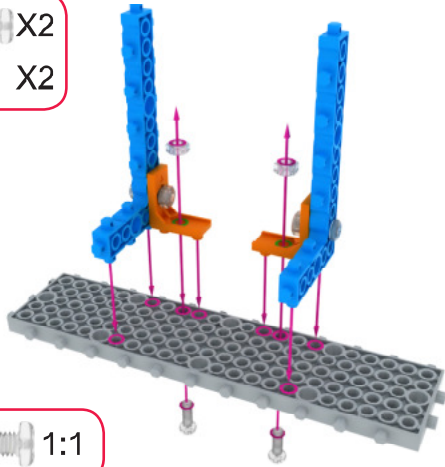

- 1:1

4

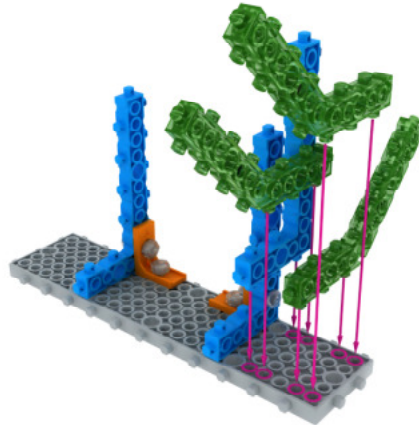

5

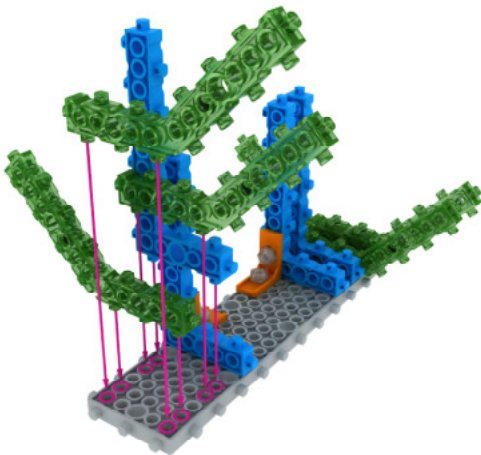

6

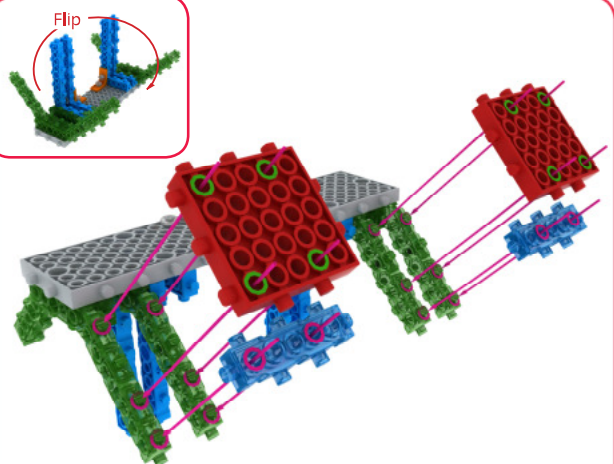

7

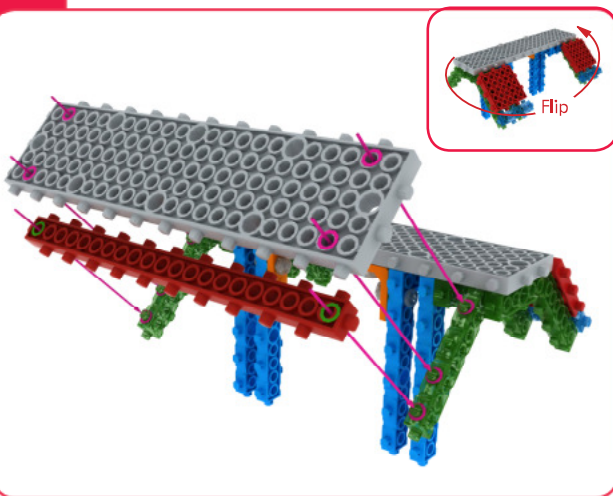

8

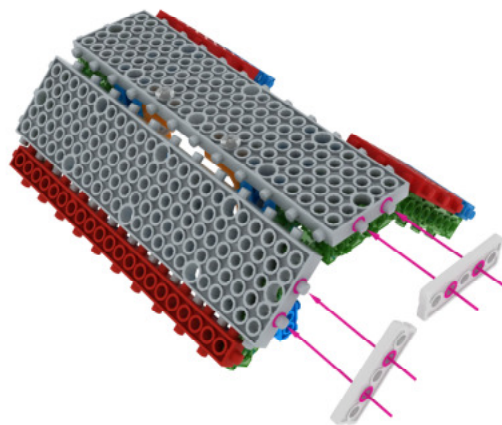

9

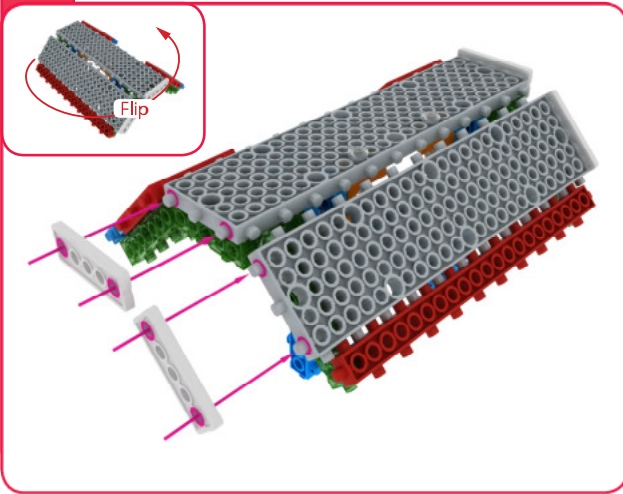

10

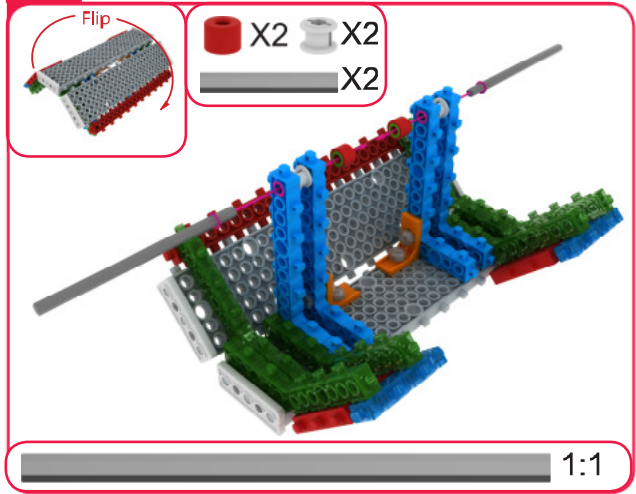

11

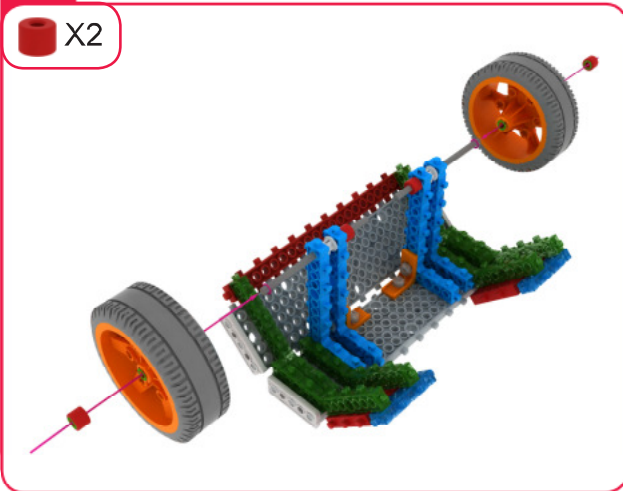

12

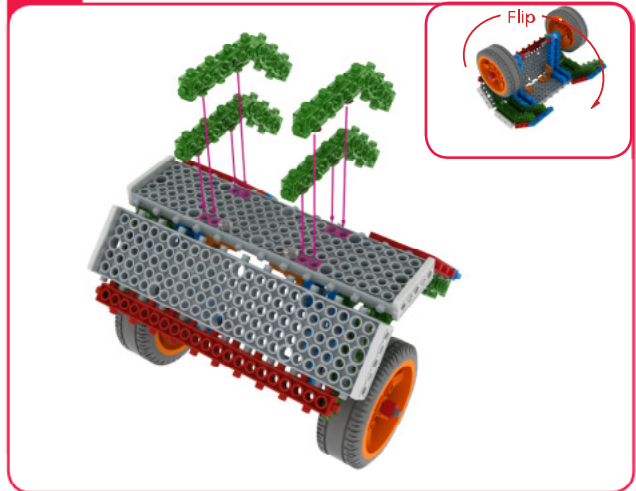

13

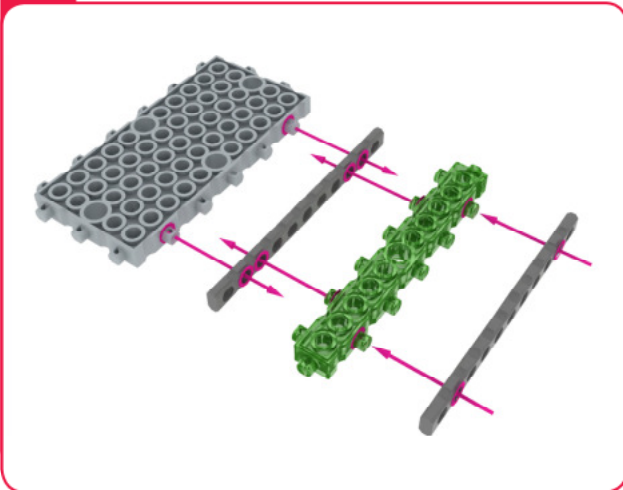

14

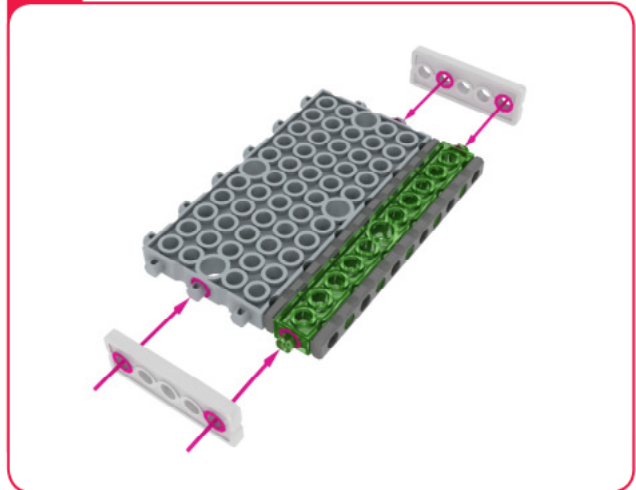

15

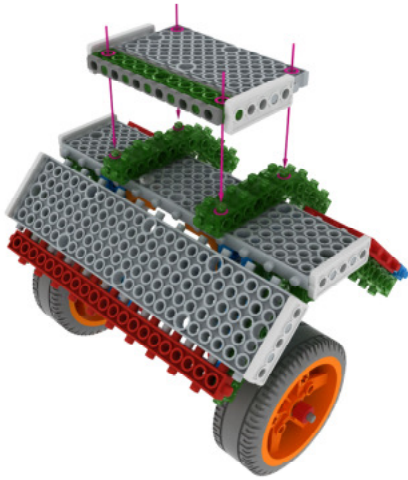

16



17

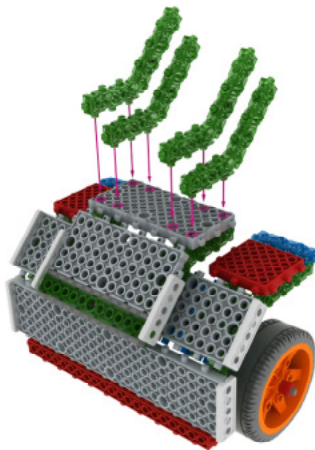

18

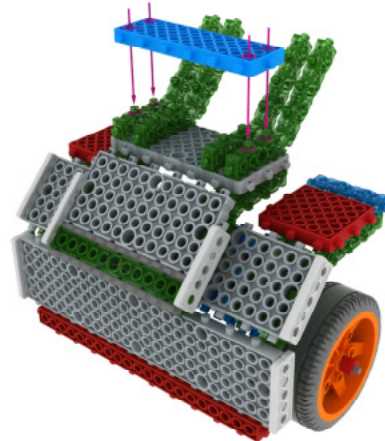

19

-  X2
-  X2

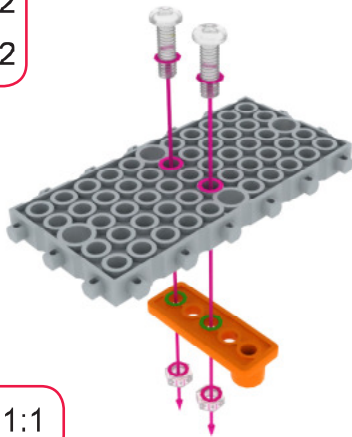

-  1:1

20

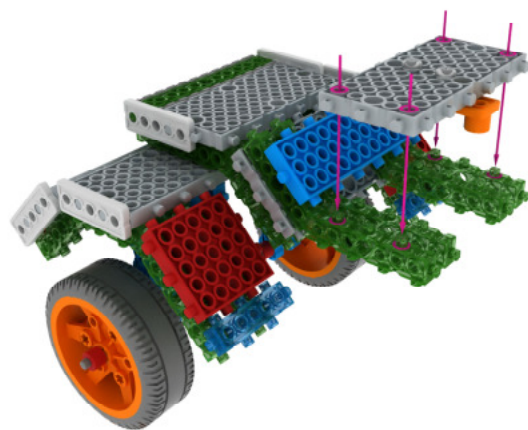

21

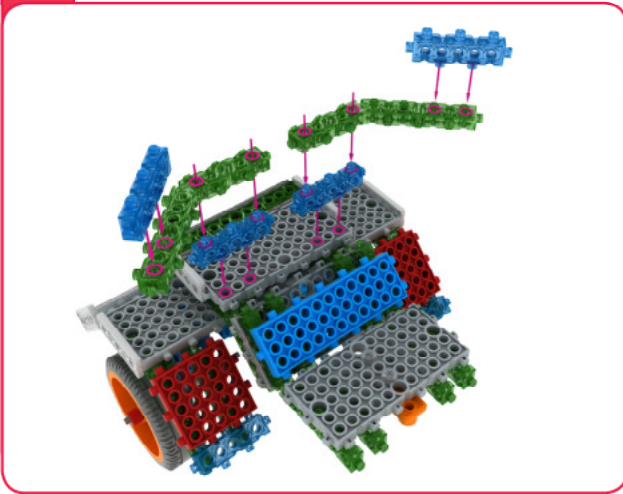

22

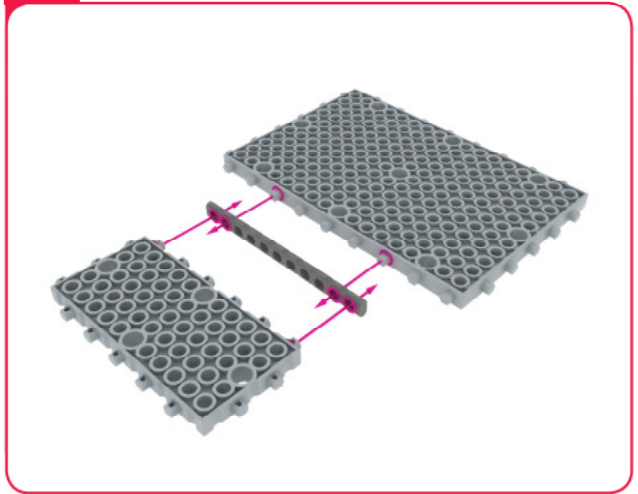

23

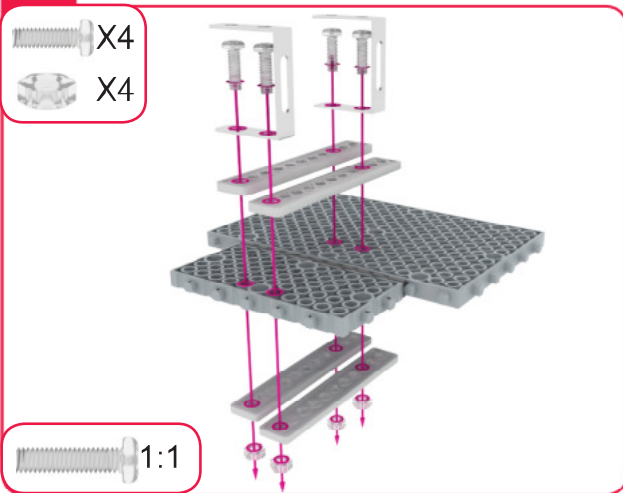

24

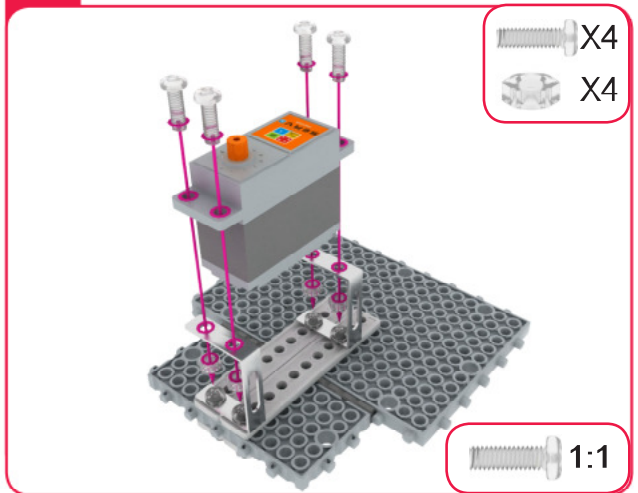

25

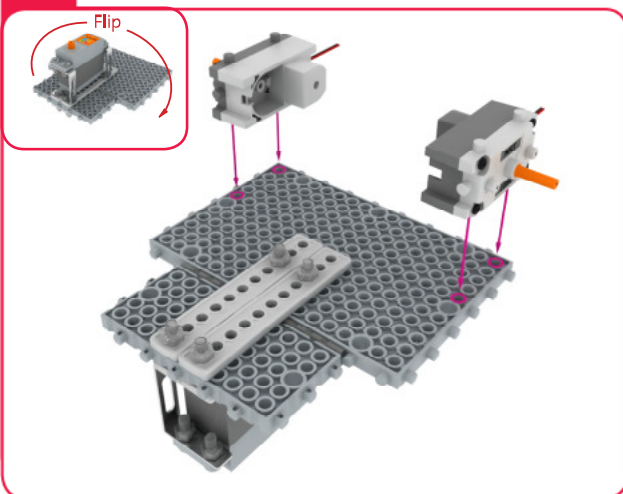

26

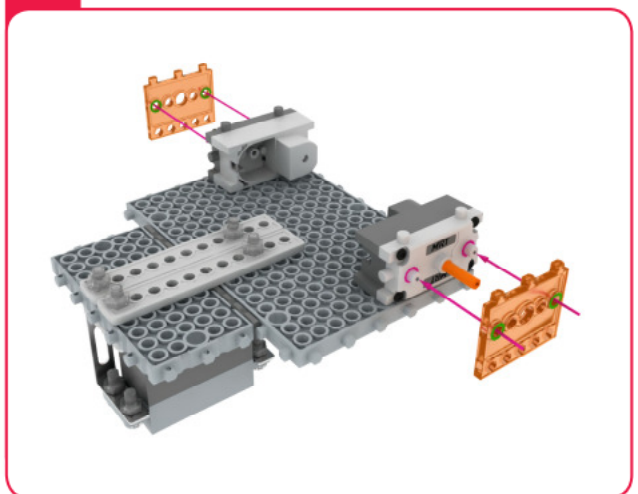

27

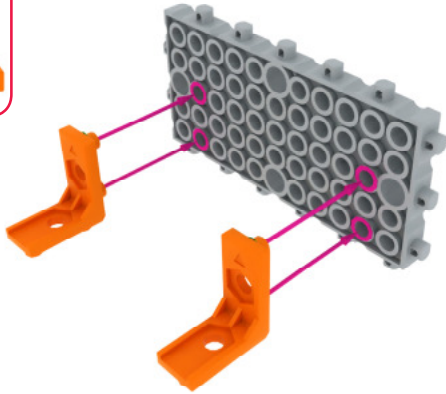

28

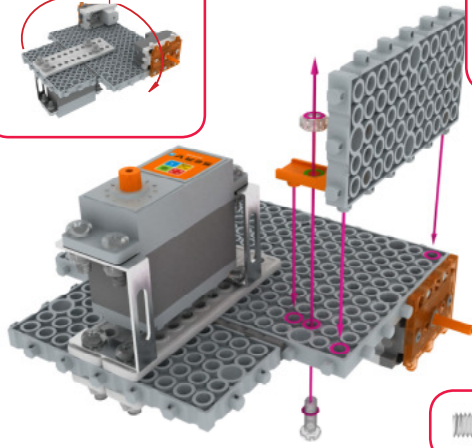
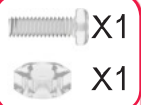
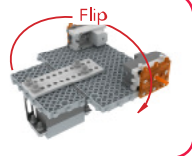

29

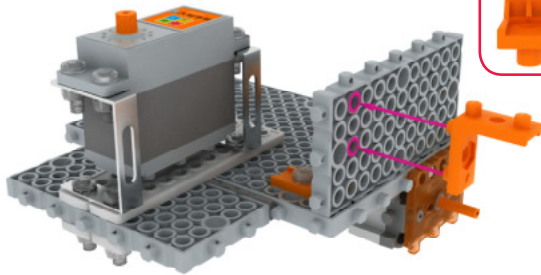

30

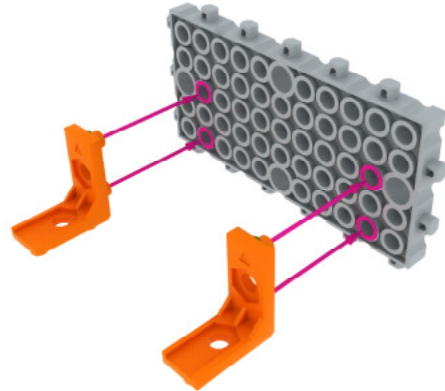

31

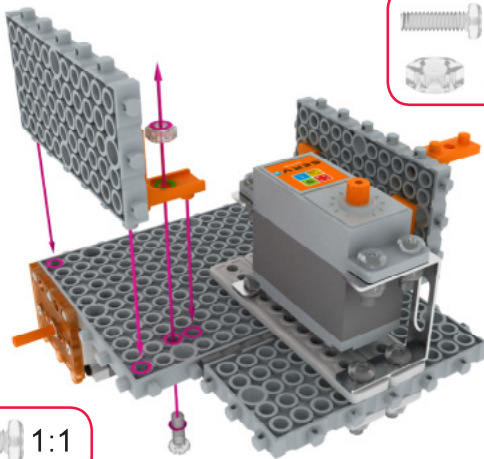
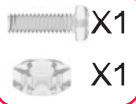

32

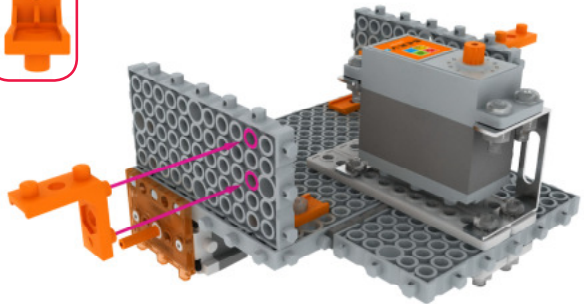

33

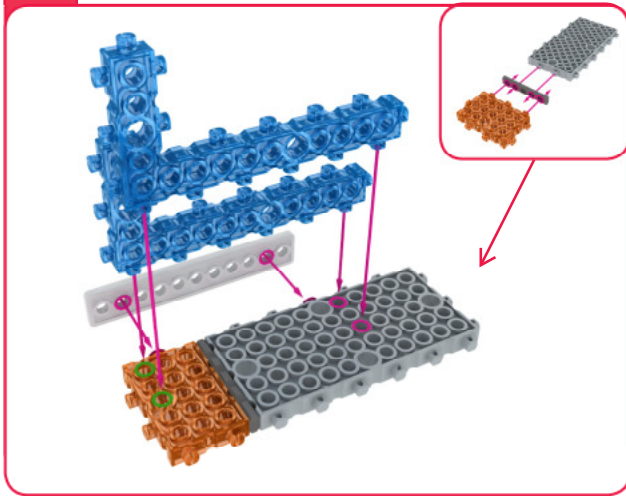

34

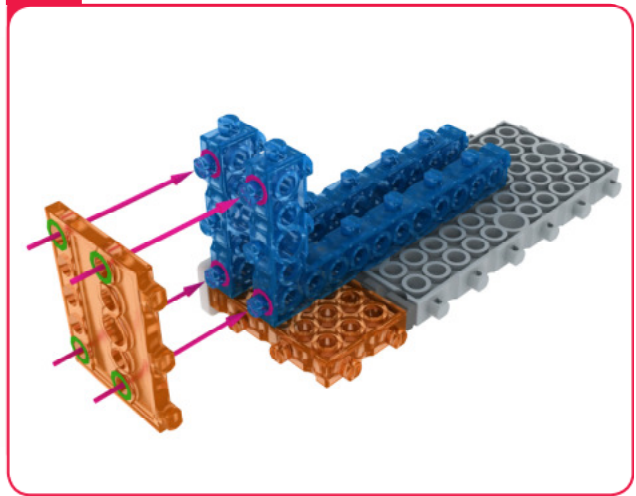

35

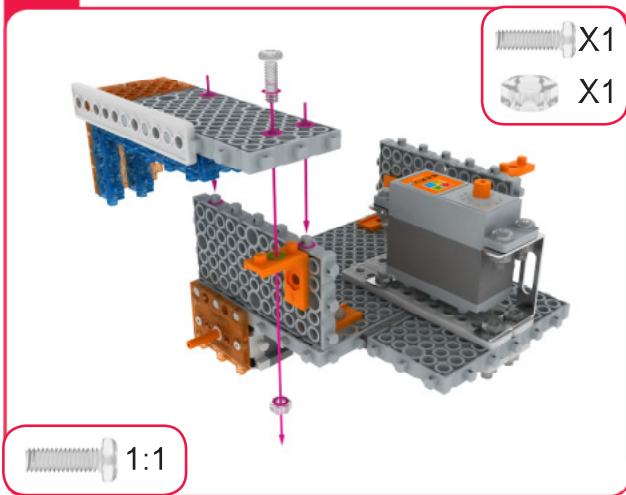

36

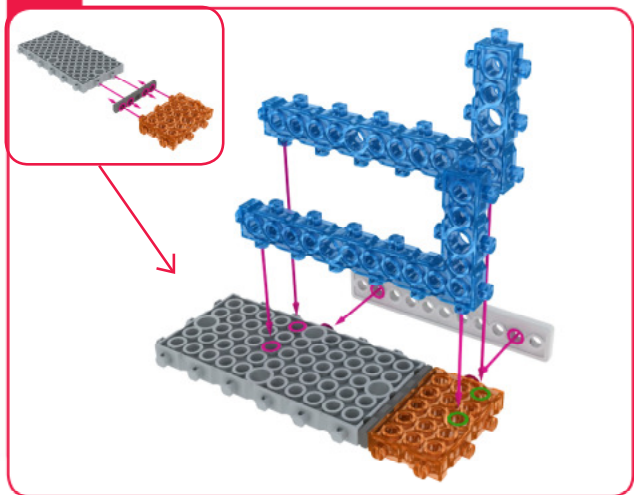

37

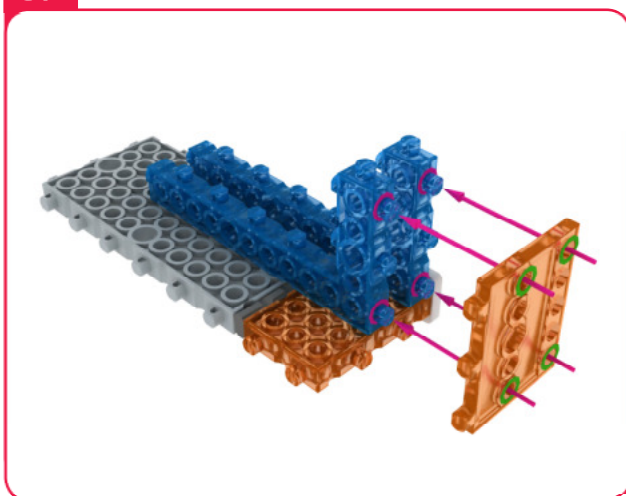

38

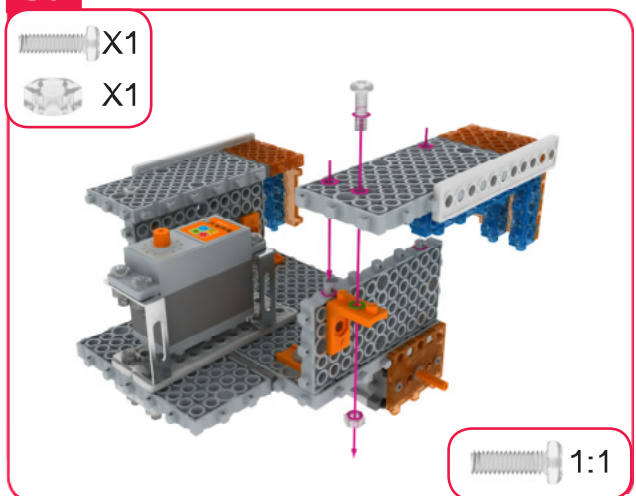

39

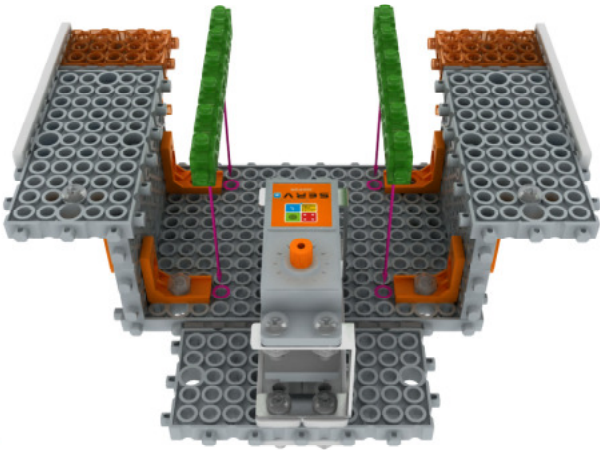

40



41

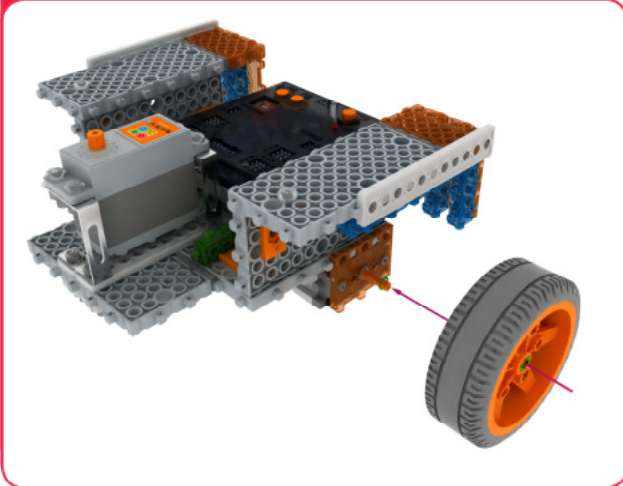

42

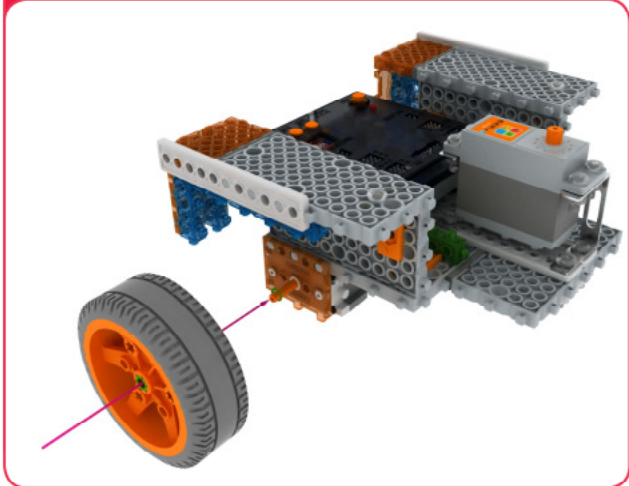

43

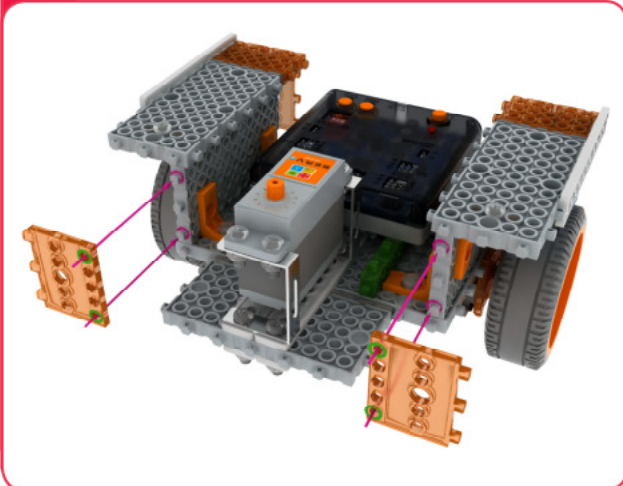

44

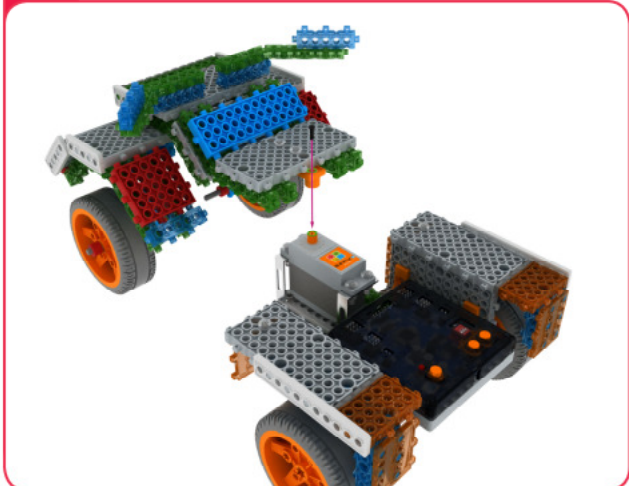

Servo Motor-Zero Point Adjustment

1. Connect the servo motor to the mainboard. You can write the program in the following way.

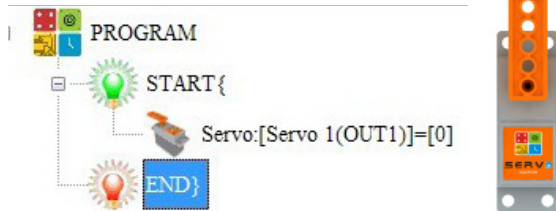

2. After downloading the program, power off and on again.
3. Fix servo motor horn to the servo motor with a small servo bolt as illustrated in the picture .

45

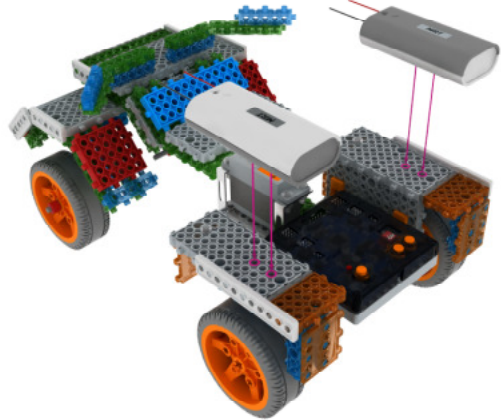

46

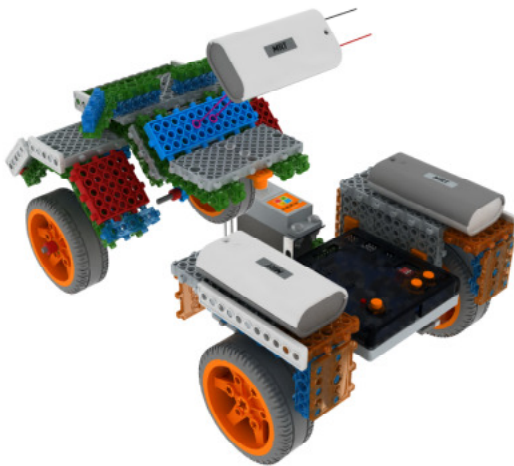

47

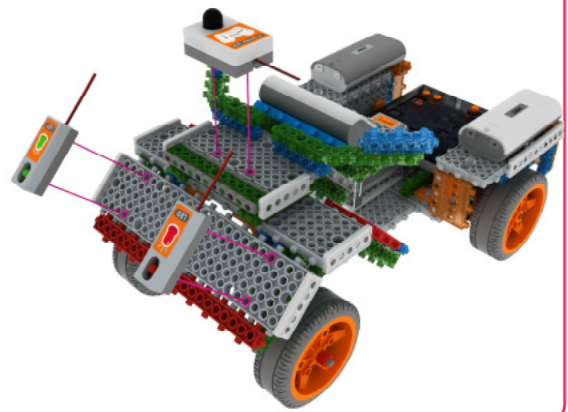

End

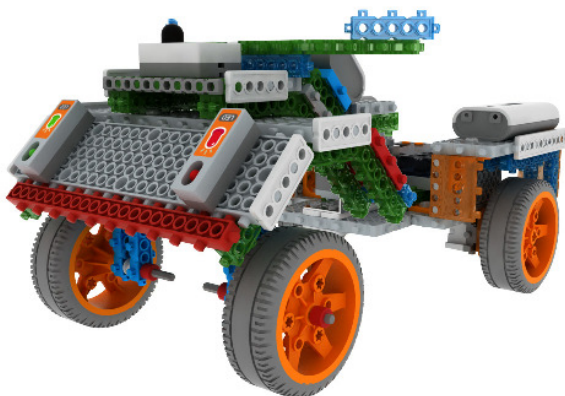

Mountain Motor bike

How to operate the Mountain Motor bike

Connecting the main board

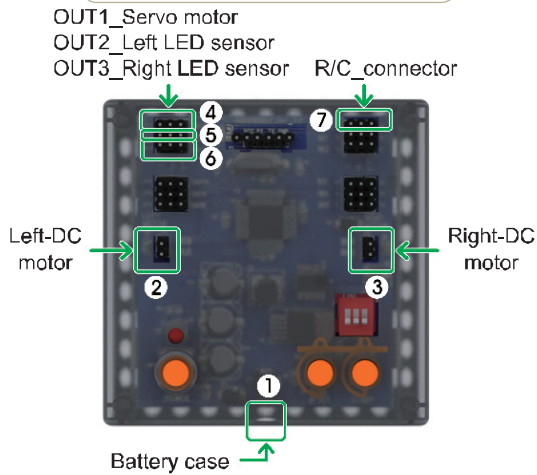

Connect in this order.

1. Connect Battery Cases to Power connector.
2. Connect Left-DC motor to Left-motor connector.
3. Connect Right-DC motor to Right-motor connector.
4. Connect Servo motor to OUT1 of OUTPUT connector.
5. Connect Left LED sensor to OUT2 of OUTPUT connector.
6. Connect Right LED sensor to OUT3 of OUTPUT connector.
7. Connect RC receiver board to R/C connector.

Motion Pattern/Program



※ Using the motion patterns as reference, let's write the program.

Program Download

1. Write the program.
2. Make sure Power / DC Motor connector and sensor's connector are well connected.
3. Check the power OFF state, then insert the download cable.
4. 'SAVE' and click the 'DOWNLOAD' button on the program window.
5. Turn on the power when 'DOWNLOAD' window opens. (Power ON)
6. Once the download is completed, remove the download cable and then turn the power off and on.
(Power OFF → Power ON)

Program Example

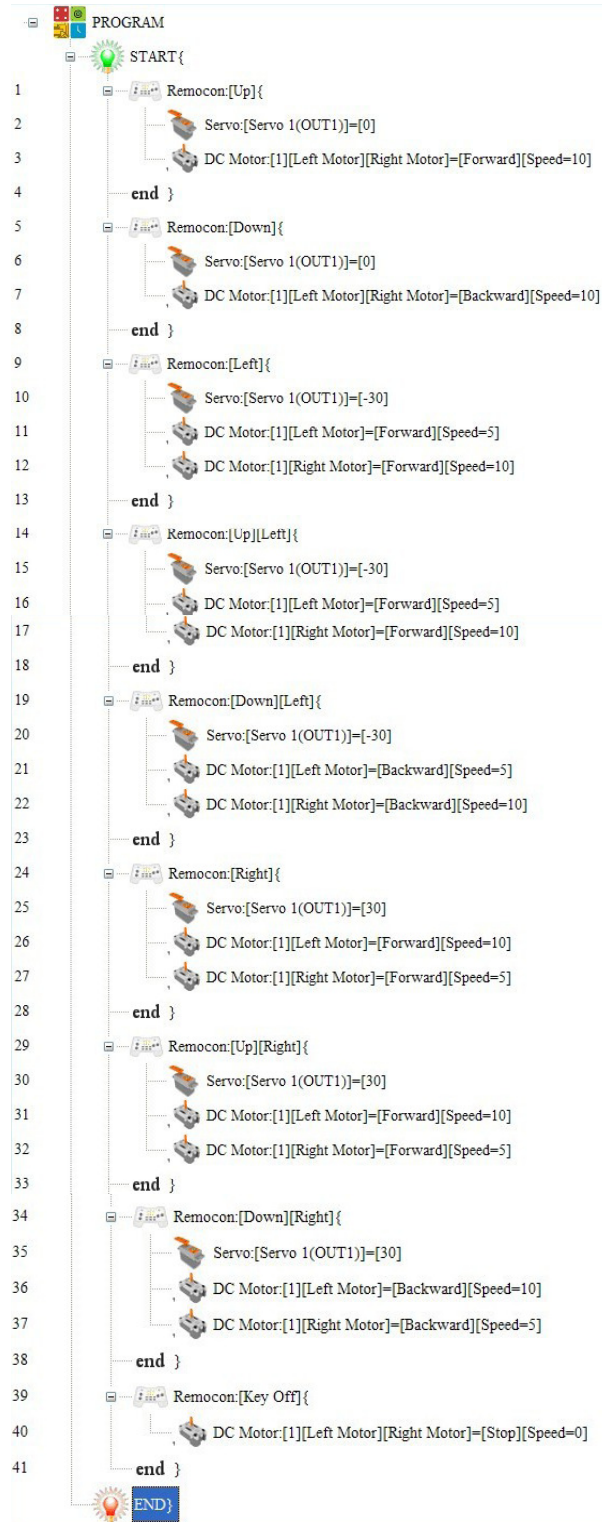



Science

**STEM 10. Transformation
magician—Electric Energy**

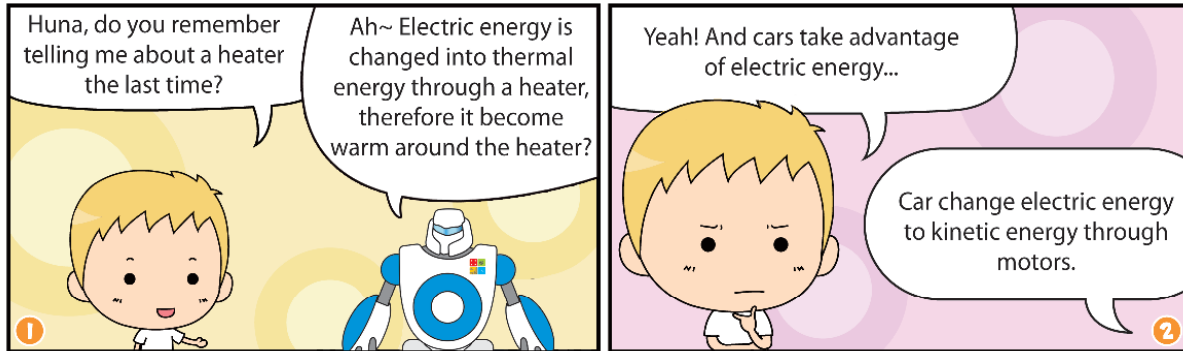

Go and take a look at things that changes electric energy to other kinds of energy.

Spiral notebook page with horizontal lines for writing.



Science

Technology

STEM 11. How a long slender thing can move a lot of things—Link

1 It's raining. I think it'll be good if we put on the windshield wipers.

2 I can see clearly now. By the way, do you know how windshield wipers work?

3 Isn't it just operated by the engine of the car as well?

4 Actually, it's not. The link in the car makes the windshield wipers work.

5 It changes rotary motion to reciprocating motion using connection links.

6 The rotary motion can be reciprocated to a horizontal motion of the windshield wipers.

7 Yeah~ These kinds of devices are used in many places.

8 I think I've also seen the link they use on trains. Is it the long thing that is connected to all of the train's wheels?

9 Oh~ Peter, all of a sudden you are interested in machinery. You're right, there's link at a train's wheel, too.

From now on, I'll pay more attention to machinery.



Engineering
Art

Robot Making6-Racing Car F1

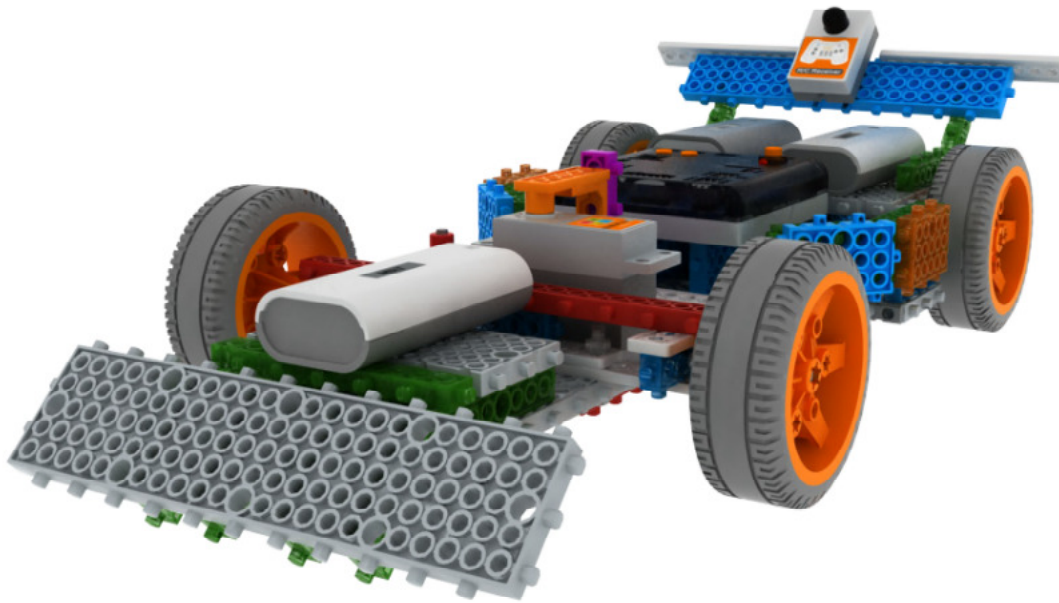

1

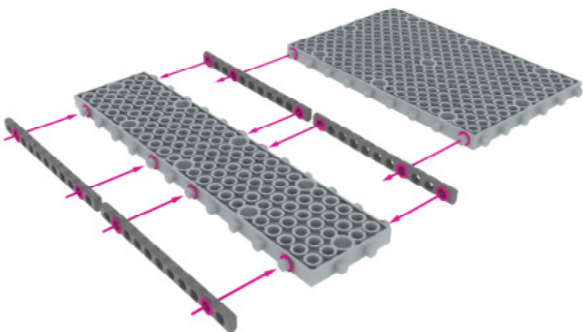

2

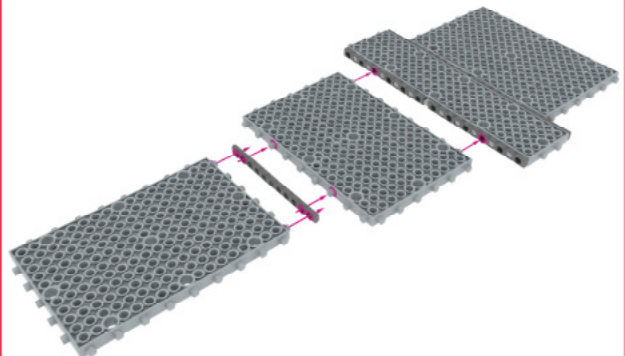

9

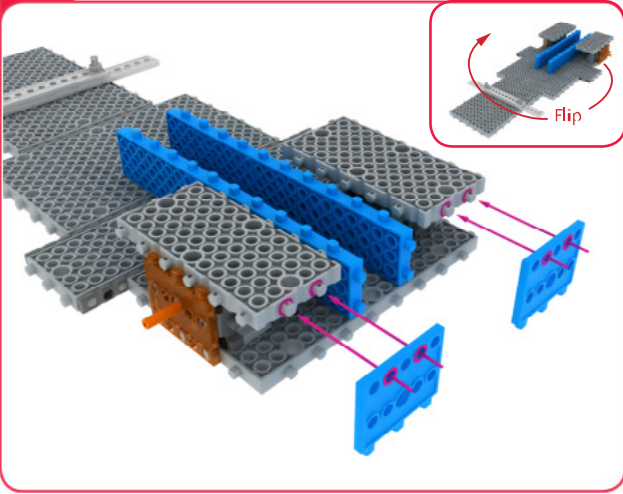

10

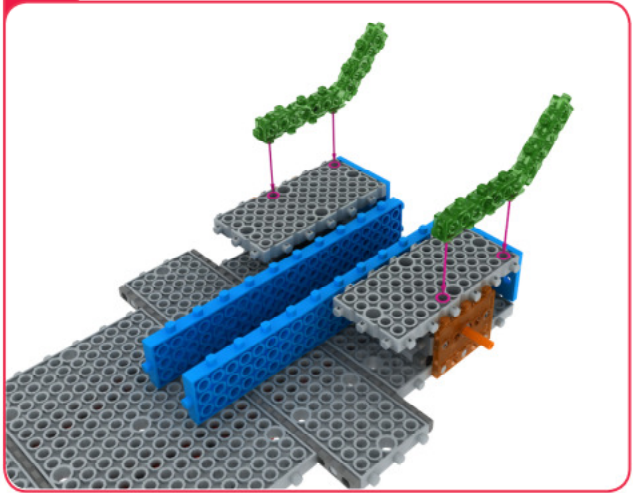

11

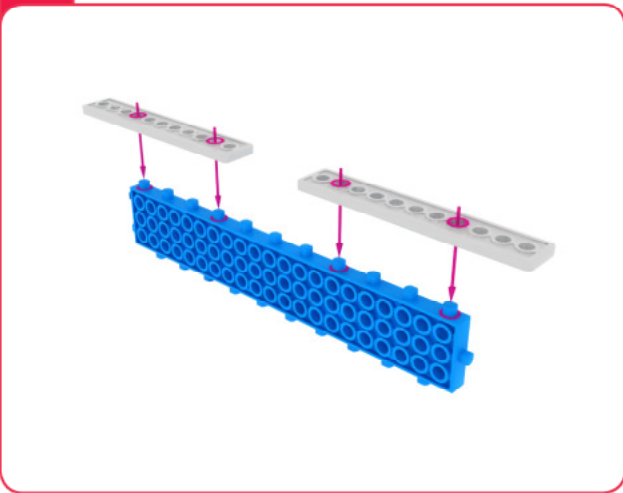

12

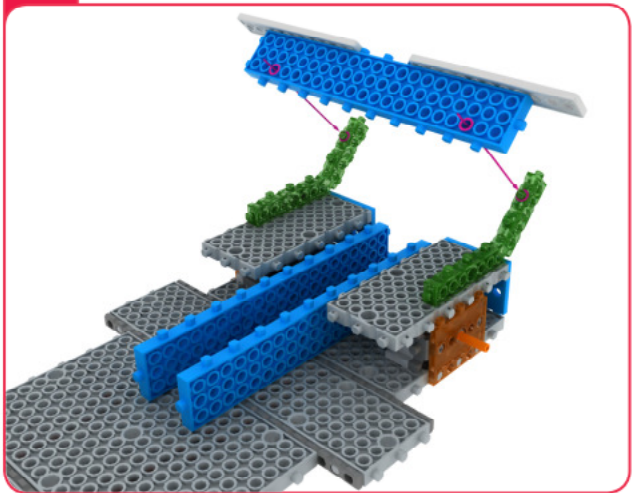

13

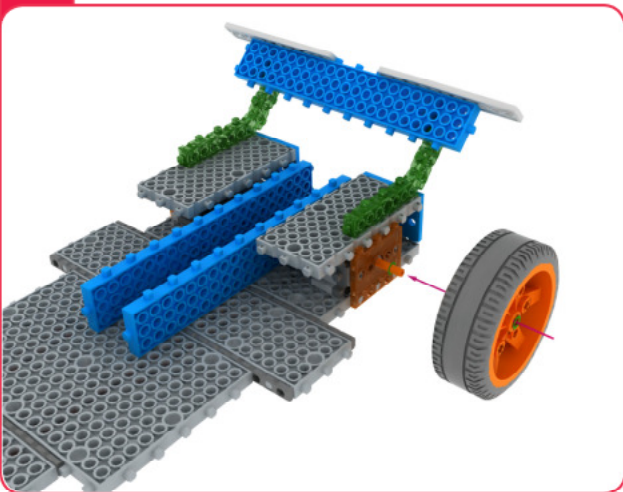

14

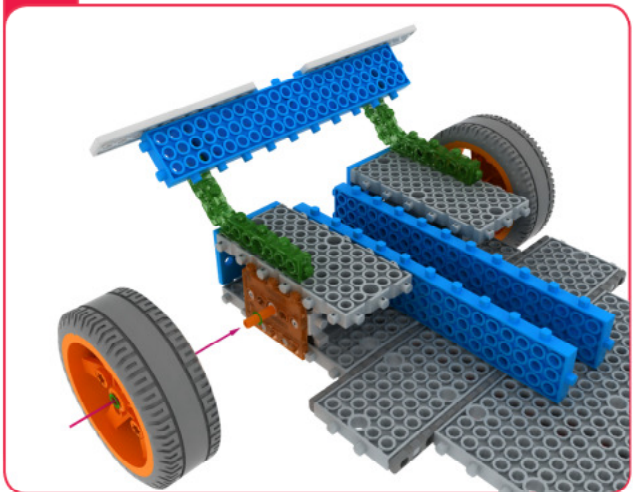

15

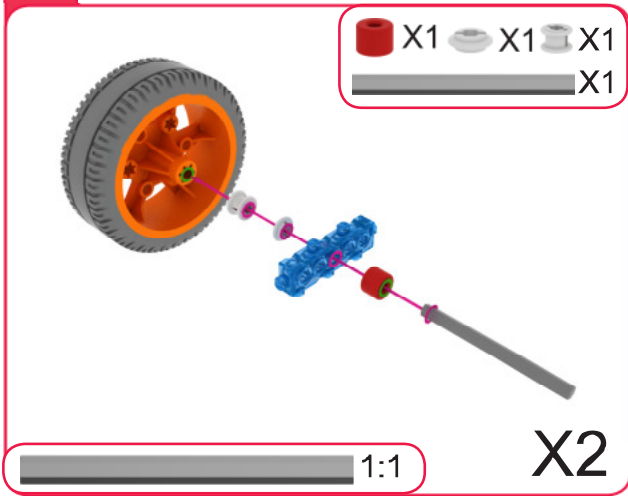

16

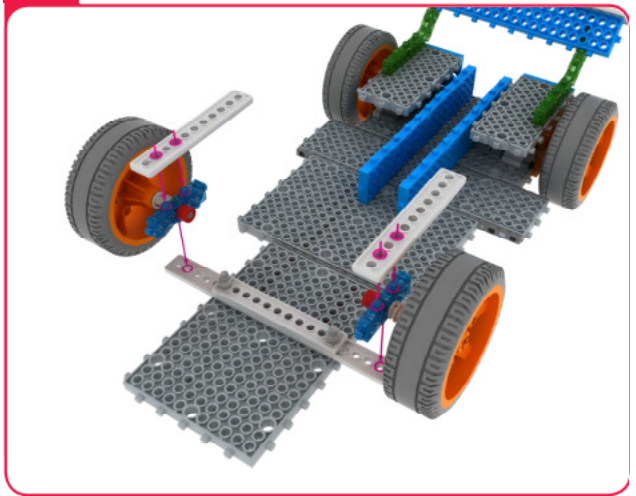

17

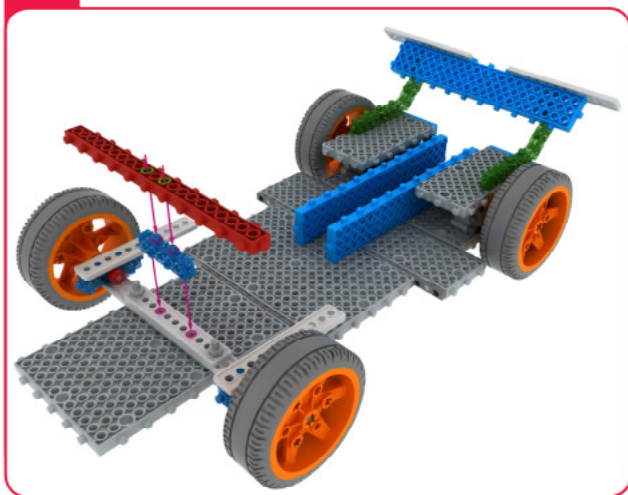

18

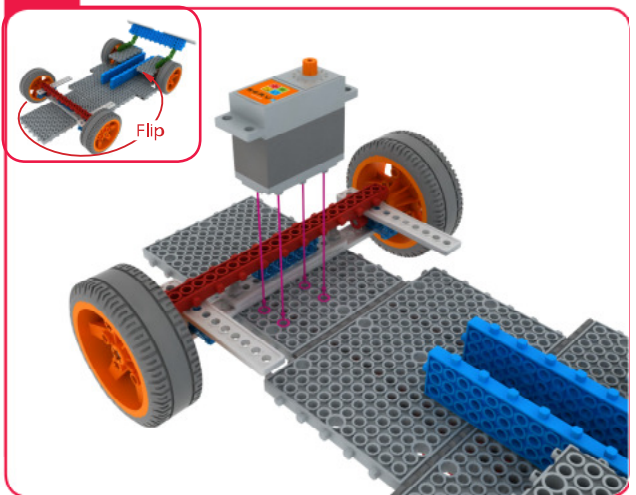

19

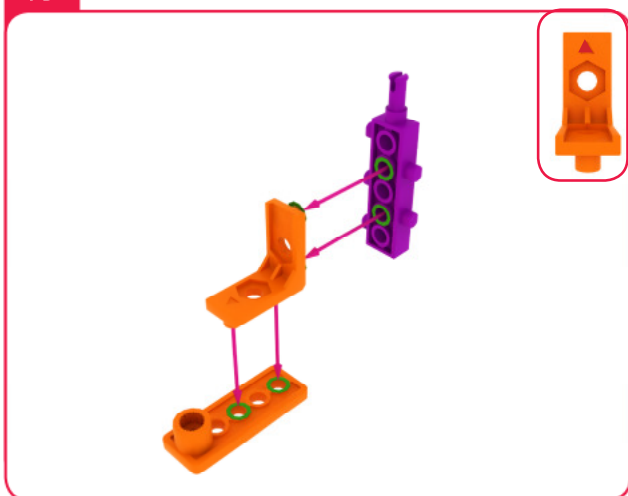

20

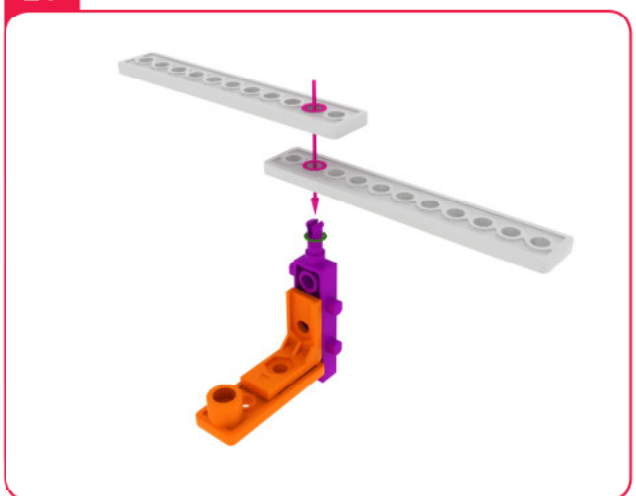

21

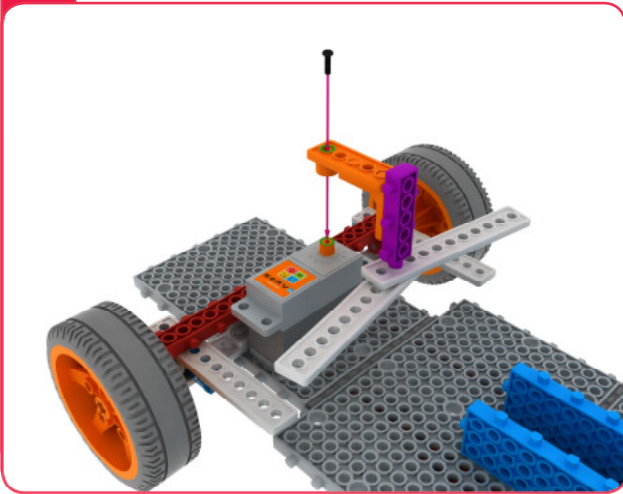

Servo Motor-Zero Point Adjustment

1. Connect the servo motor to the mainboard. You can write the program in the following way.

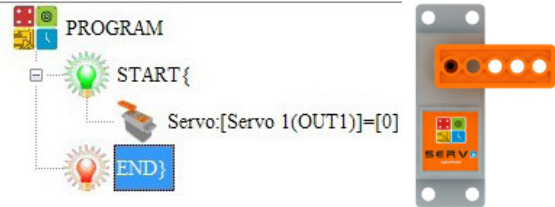

2. After downloading the program, power off and on again.
3. Fix servo motor horn to the servo motor with a small servo bolt as illustrated in the picture .

22

Red Technic Pin X1
Grey Servo Bolt X1

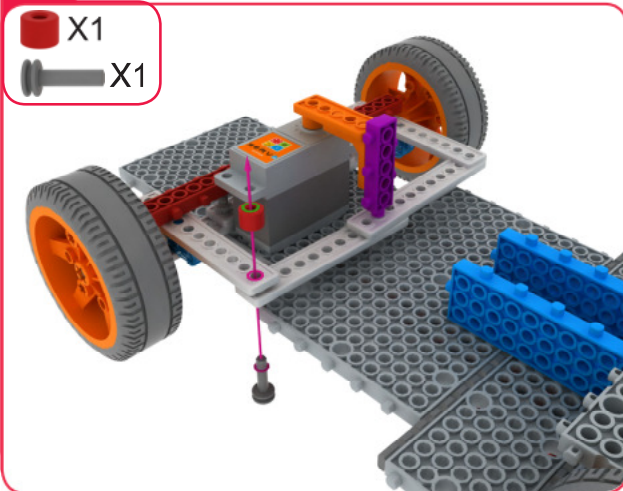

23

Red Technic Pin X1
Grey Servo Bolt X1

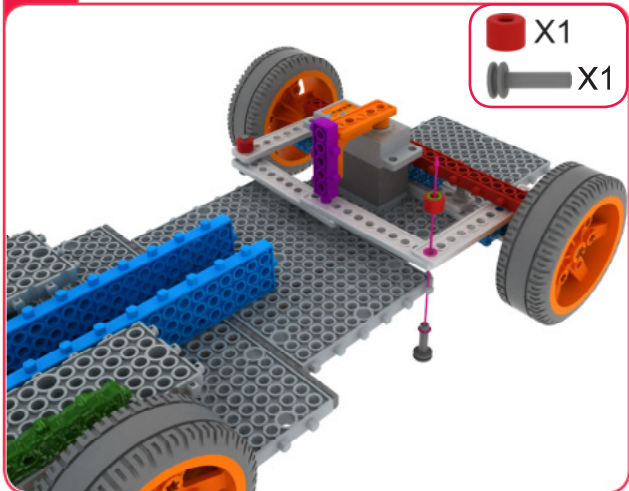

24

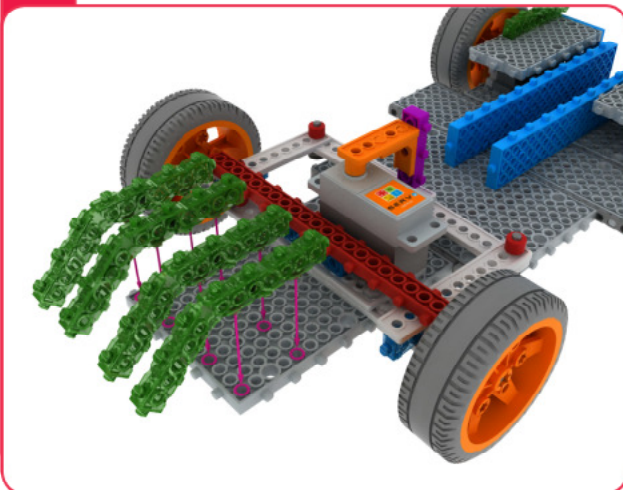

25

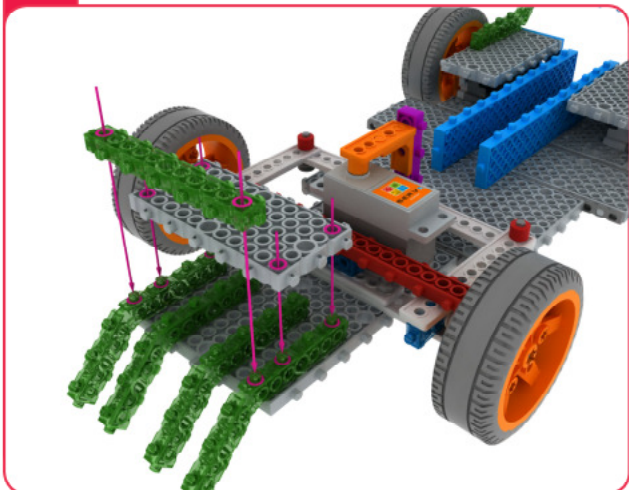

26

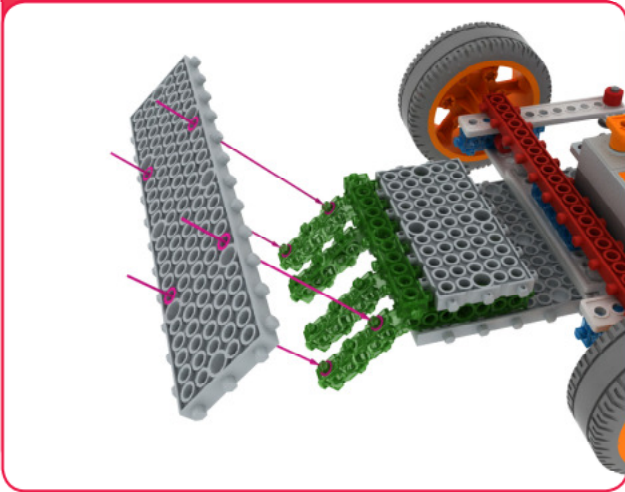

27

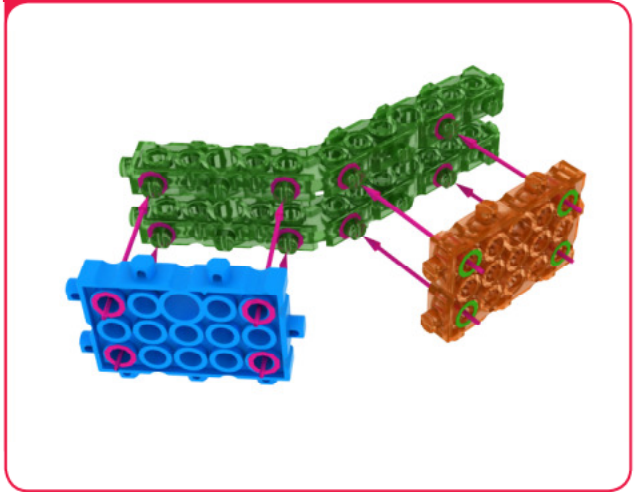

28

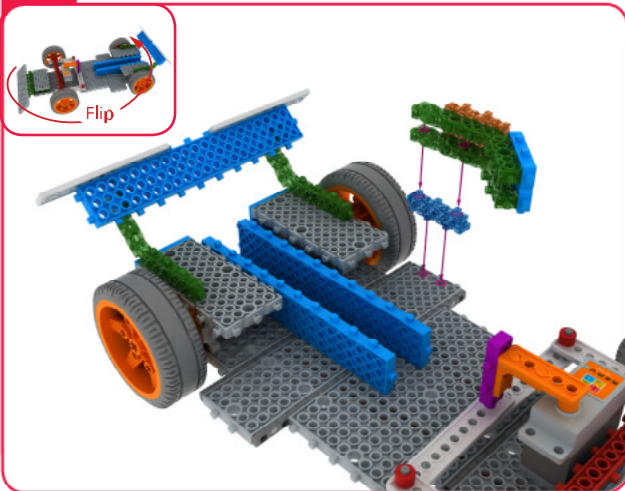

29

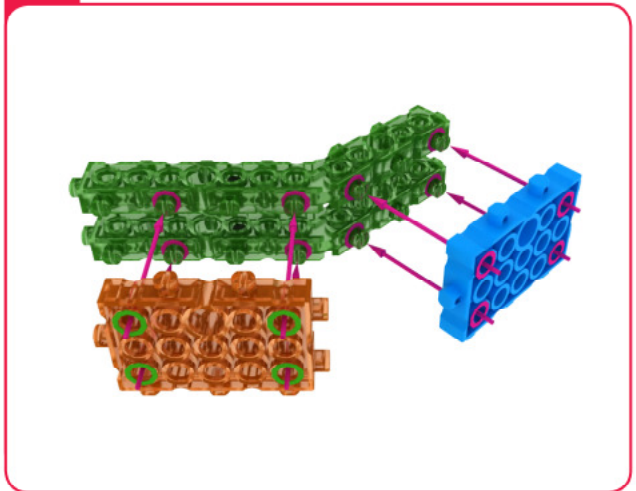

30

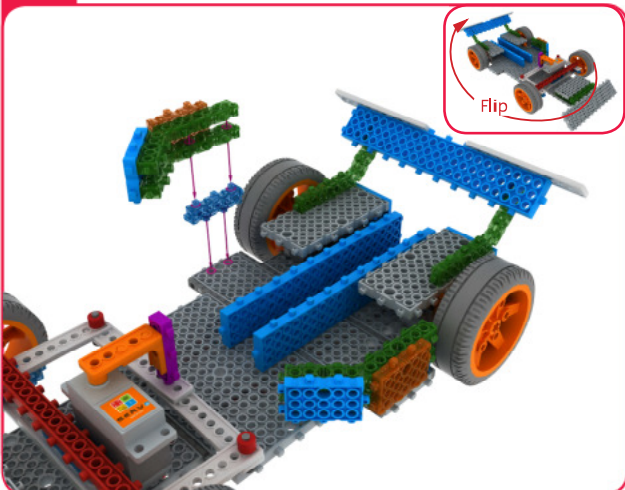

31

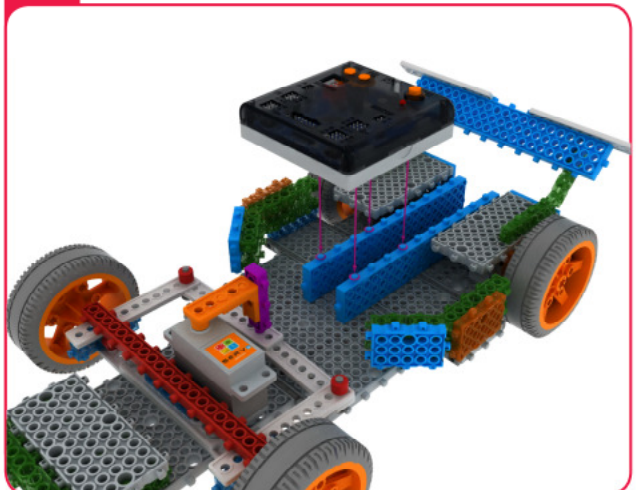

32

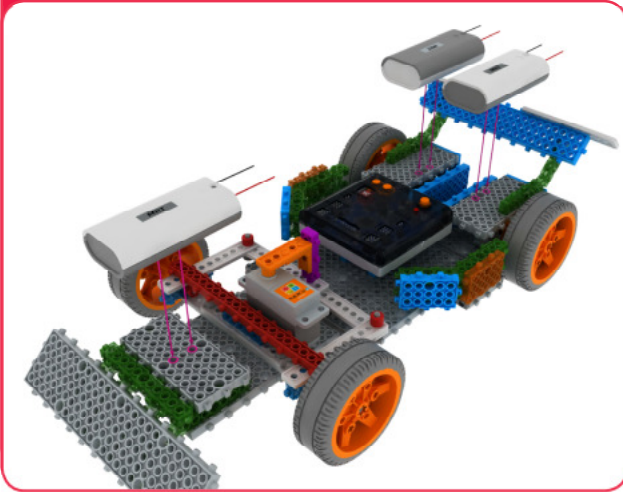

33



End





How to operate the Racing Car F1

Connecting the main board

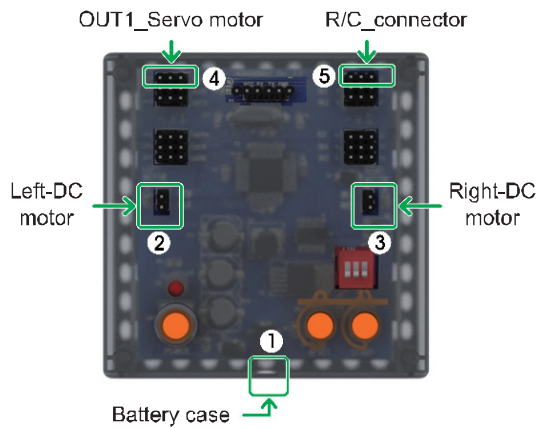

Connect in this order.

1. Connect Battery Cases to Power connector.
2. Connect Left-DC motor to Left-motor connector.
3. Connect Right-DC motor to Right-motor connector.
4. Connect Servo motor to OUT1 of OUTPUT connector.
5. Connect RC receiver board to R/C connector.

Motion Pattern/Program

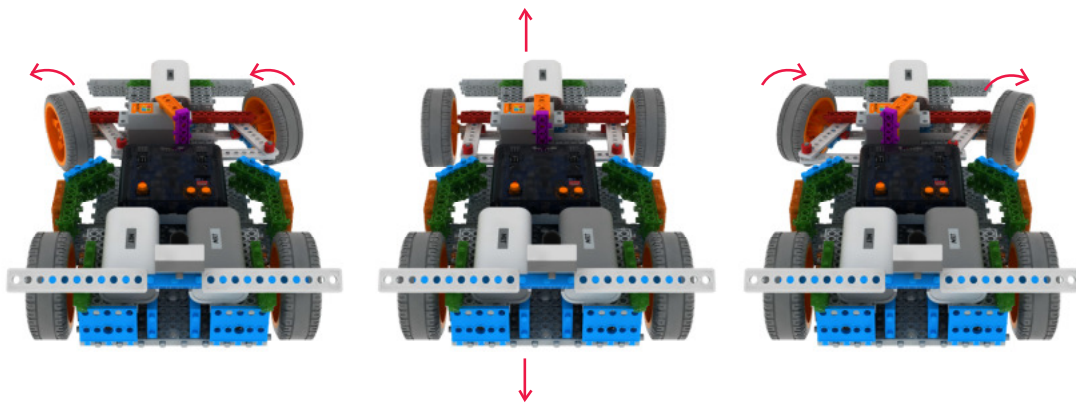

※ Using the motion patterns as reference, let's write the program.

Program Download

1. Write the program.
2. Make sure Power / DC Motor connector and sensor's connector are well connected.
3. Check the power OFF state, then insert the download cable.
4. 'SAVE' and click the 'DOWNLOAD' button on the program window.
5. Turn on the power when 'DOWNLOAD' window opens. (Power ON)
6. Once the download is completed, remove the download cable and then turn the power off and on.
(Power OFF → Power ON)

Program Example

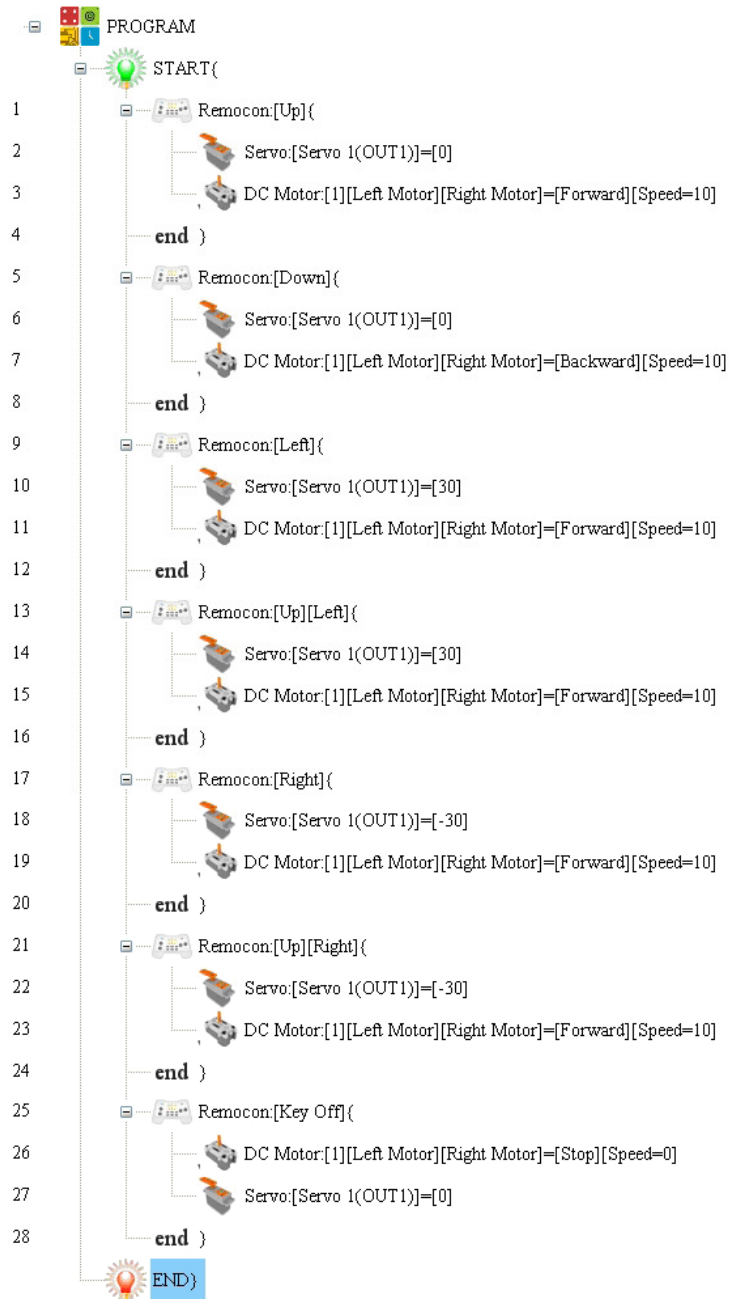



Technology
Art

STEM 12. Having a racing car race with your friends

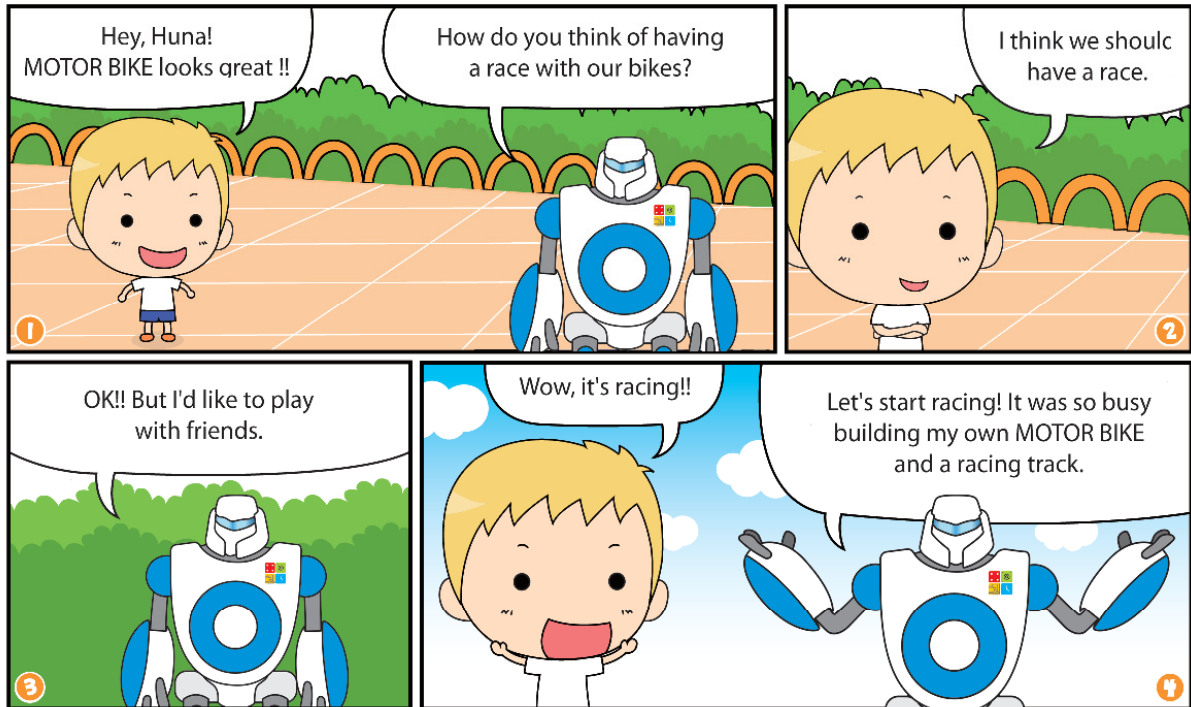

Spiral notebook page with horizontal lines for writing.



Technology

STEM 13. Intelligent robots acting like human—AI 1 (Artificial Intelligence)

1 Huna! Can you help me count these numbers?

This calculation is quite easy to perform using a computer program.

2 Can computer calculate? I play games only.

Sure! Computers have programs which have AI technology.

3 AI(artificial intelligence)? But only people can be intelligent?

Yes, but people made computer programs that works far more easier, all using human reasoning skills.

4 Wow, people can be smart as well! What a great development!

5 Robots can think like people, because they use the lessons we taught them. So they have the ability to learn.

Dose only computer have AI?

6 No~ Computer aren't the only technology using AI. How about surveillance cameras? They use AI to recognize people's faces. We can use this technology to catch criminals.

7 Wow! Great!

Isn't that amazing? AI is connected to different fields of science. It is quite helpful for scientific improvement. Another great thing is that AI can be used to prove mathematical theories.

Wow! AI is really helpful. It is amazing!



Robot Making 7-Folk lift

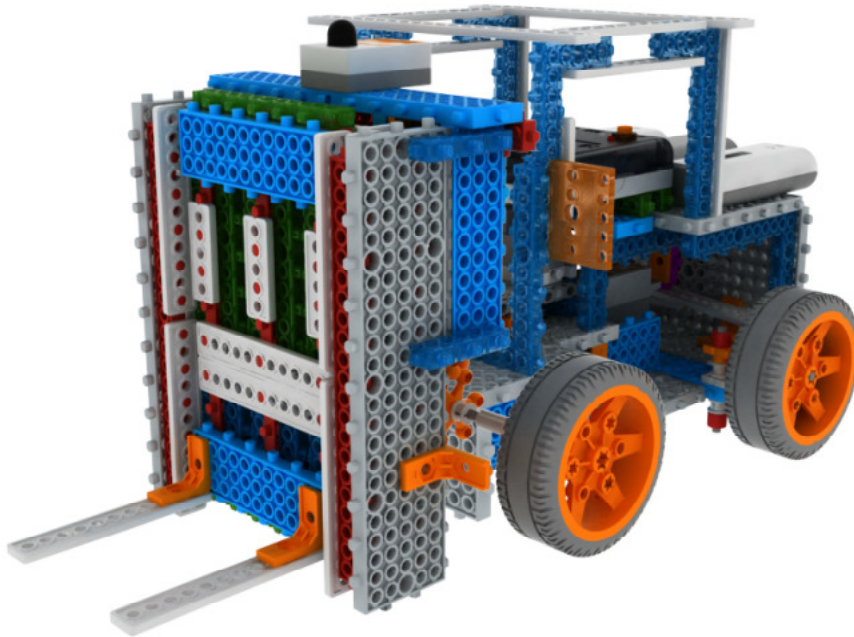

1

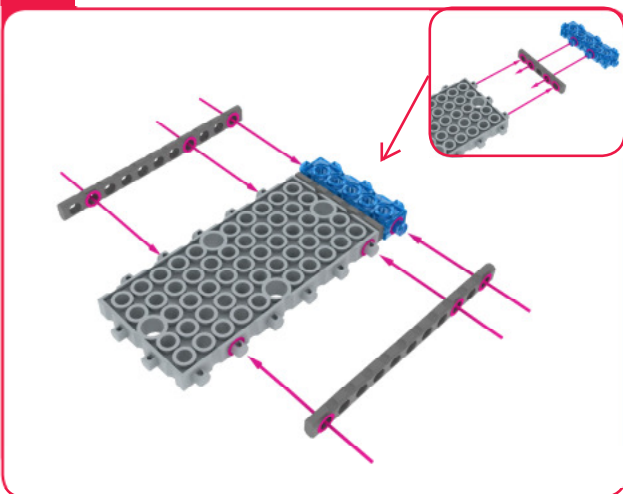

2

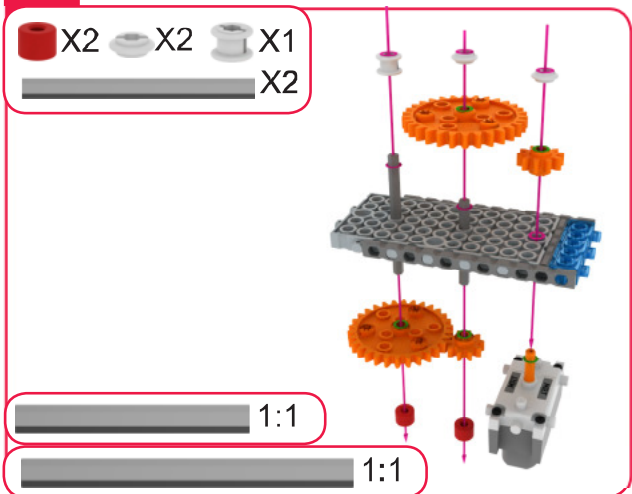

3

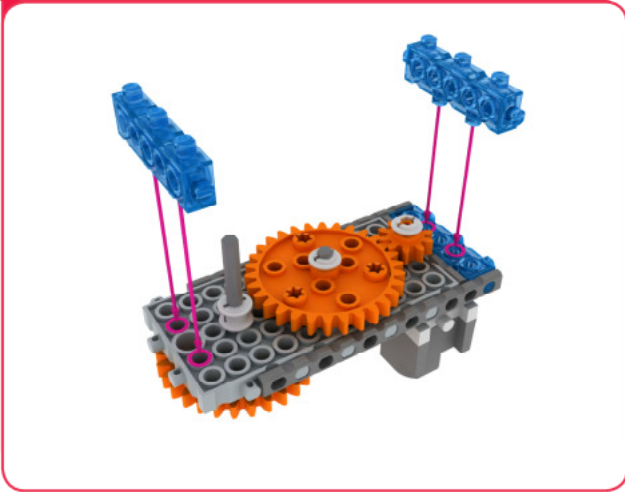

4

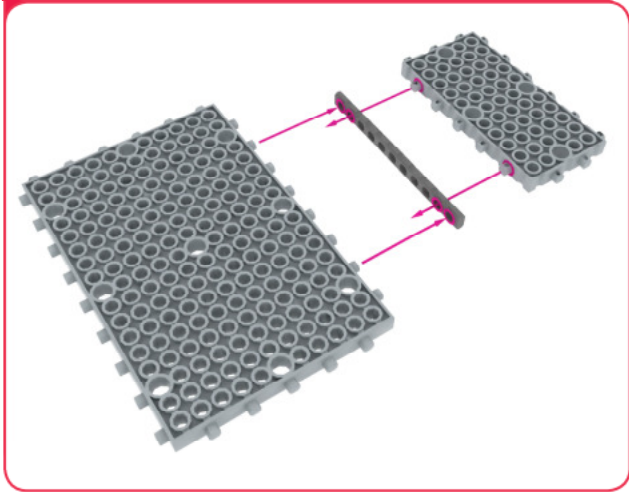

5

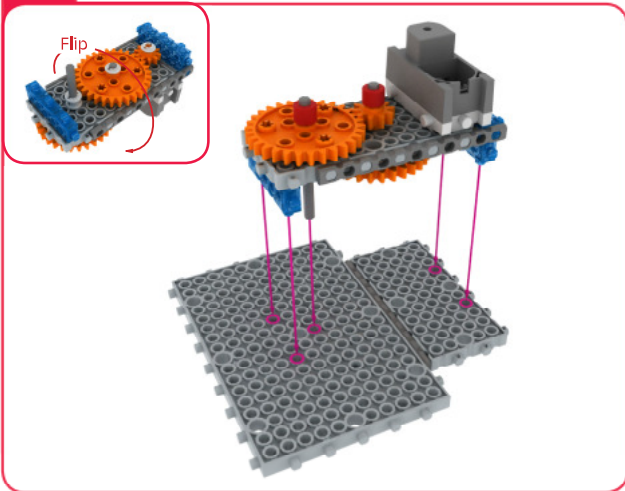

6

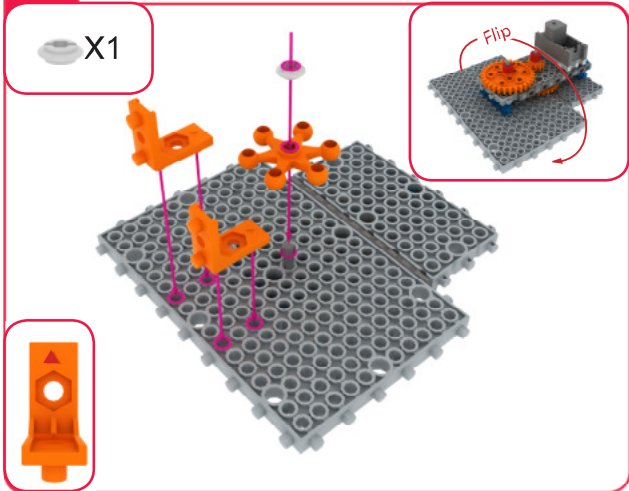

7

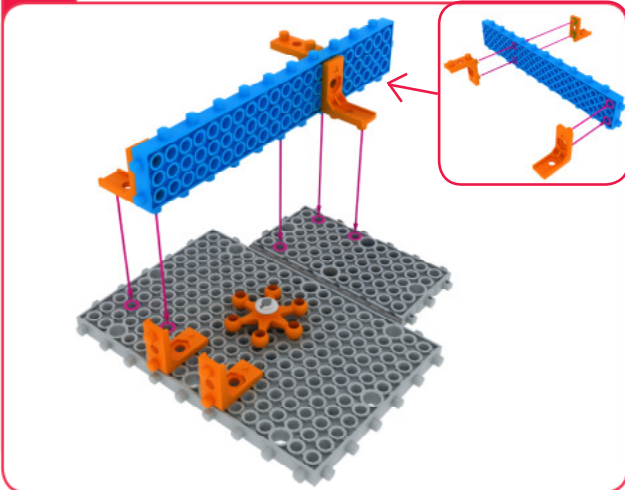

8

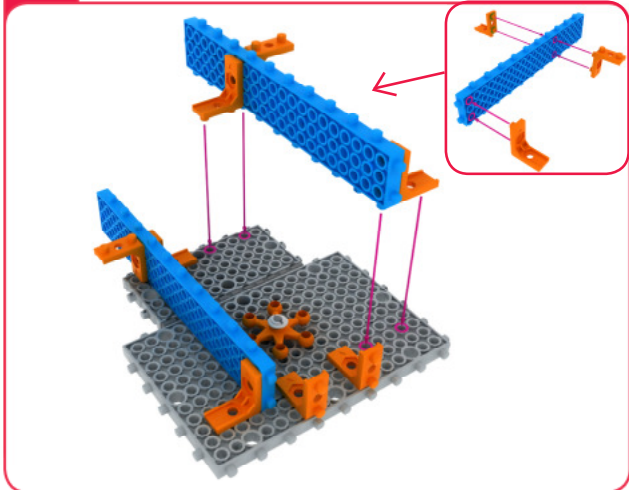

MY ROBOT TIME

9

X2 X2
X1

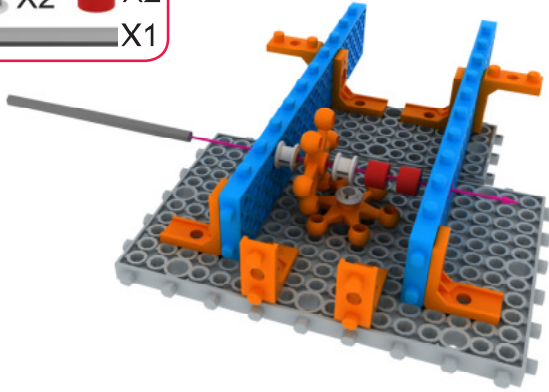

1:1

10

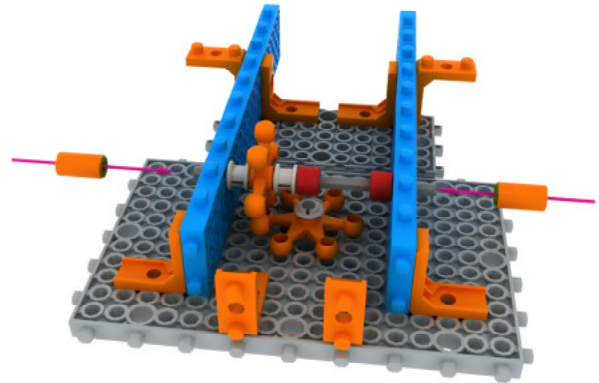

11

X4
X2

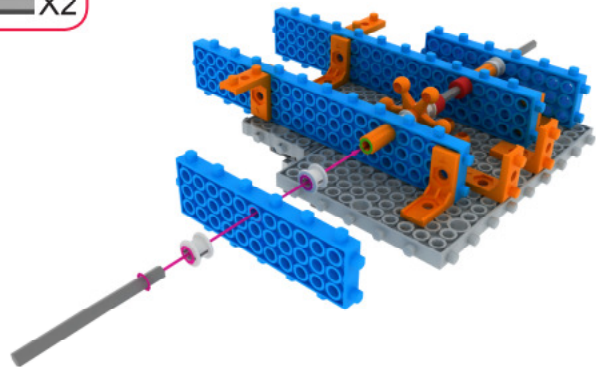
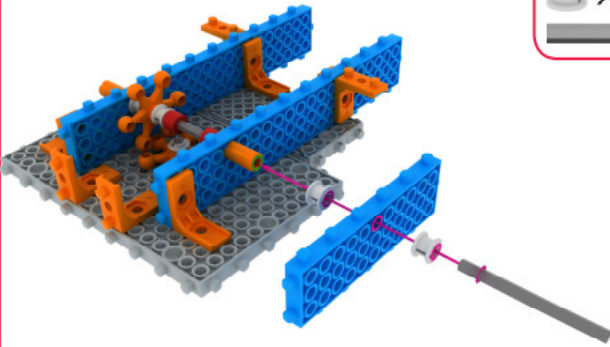

1:1

12

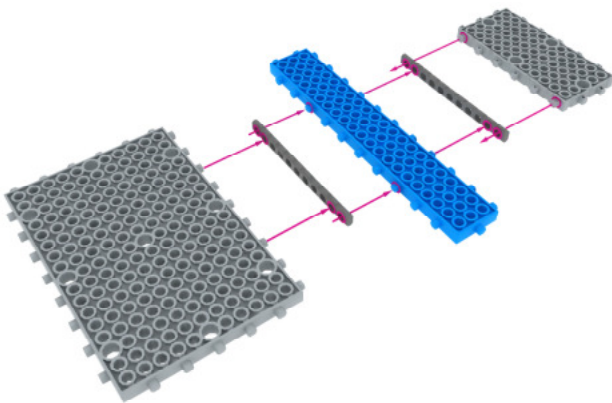

13

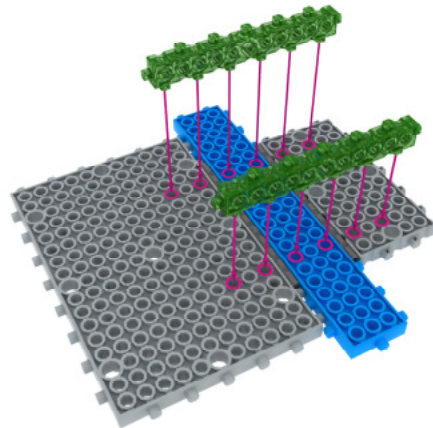

14

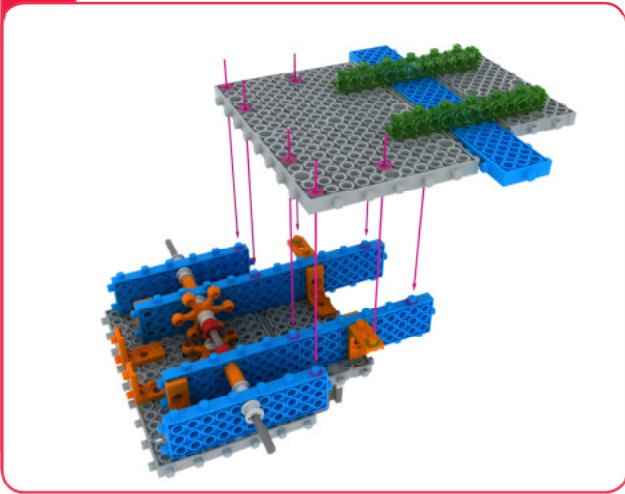

15

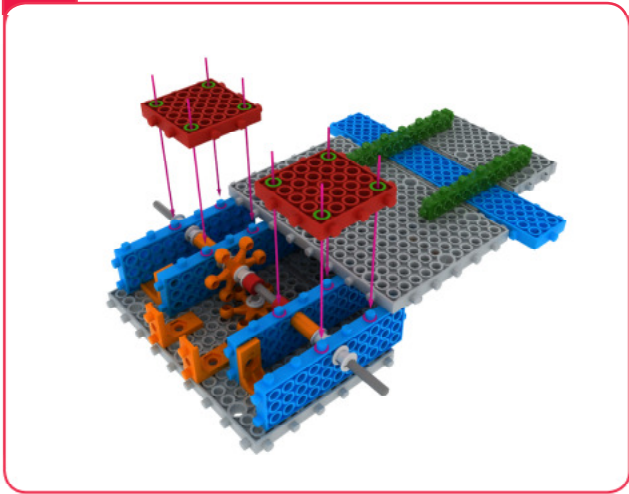

16

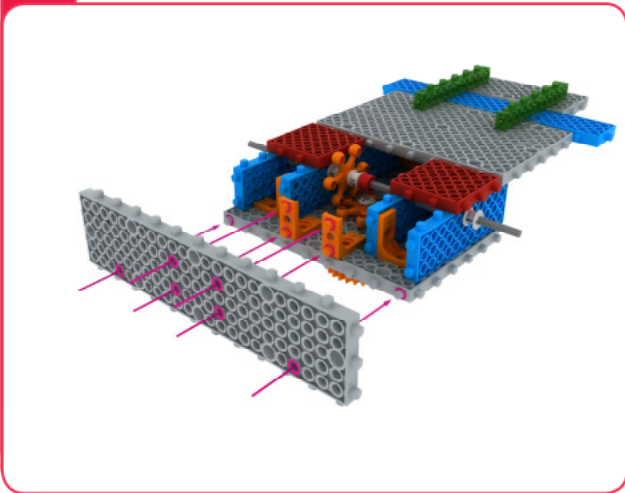

17

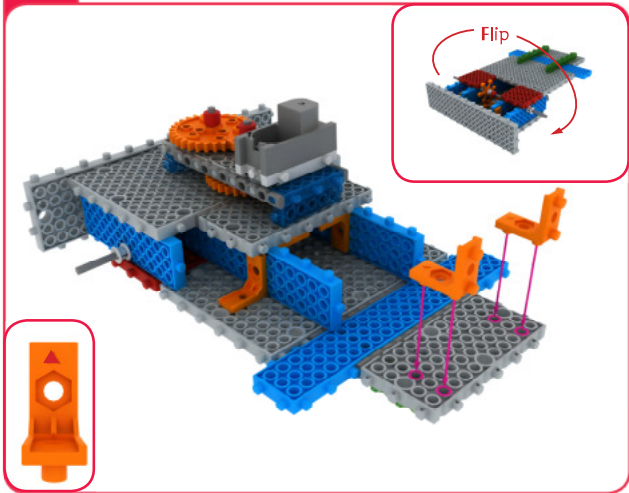

18

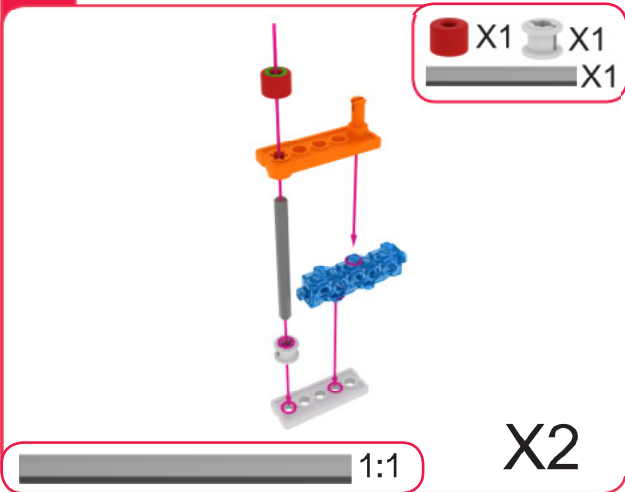

19

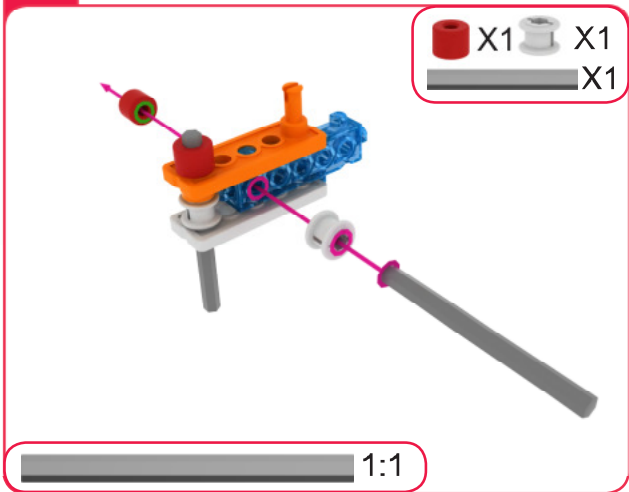

MY ROBOT TIME

20

X1 X1 X1



1:1

21

X1 X1

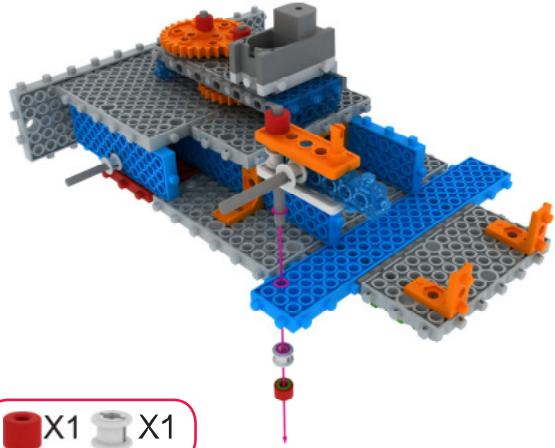

22

X1 X1

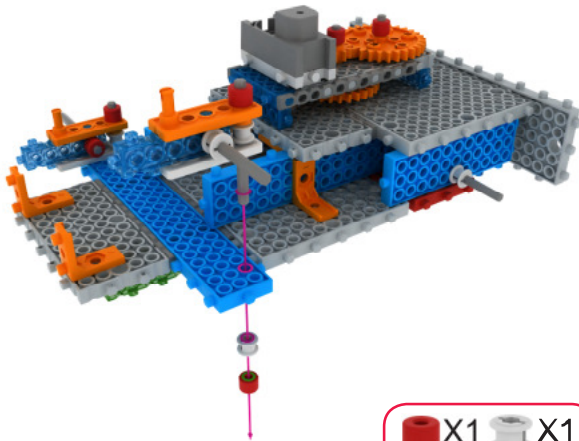

23

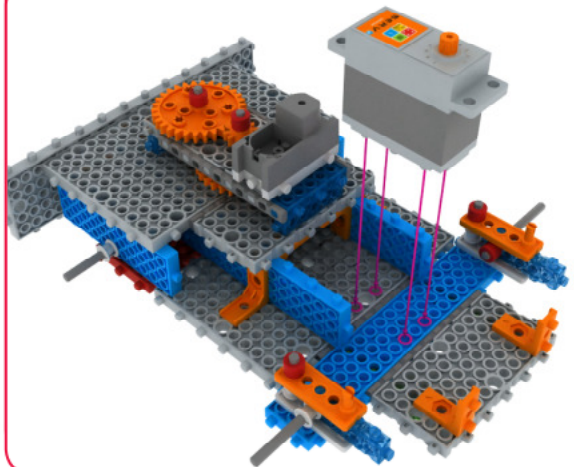

24

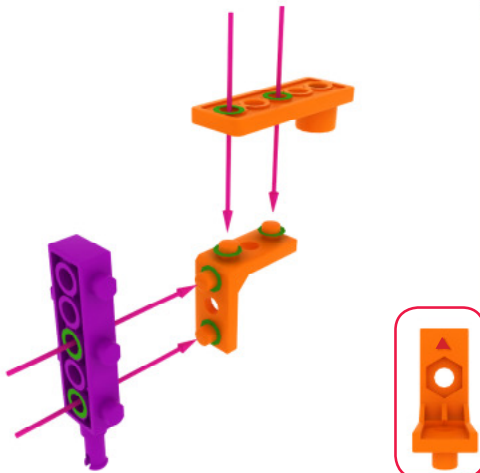

25

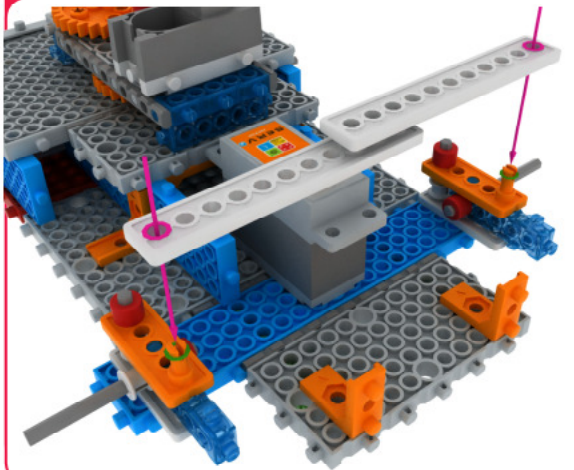

26

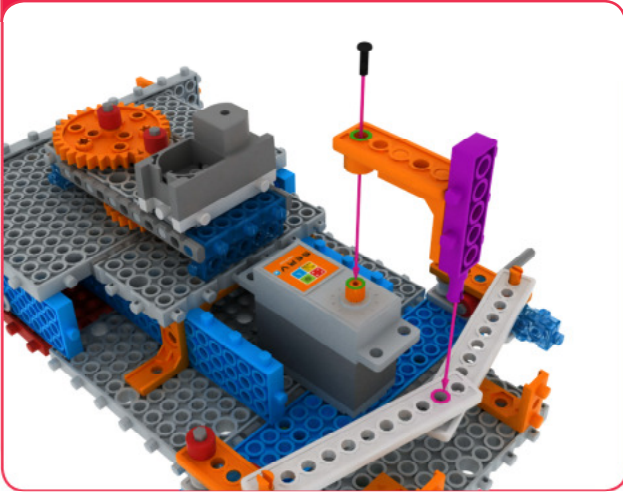

Servo Motor-Zero Point Adjustment

1. Connect the servo motor to the mainboard. You can write the program in the following way.



2. After downloading the program, power off and on again.
3. Fix servo motor horn to the servo motor with a small servo bolt as illustrated in the picture .

27

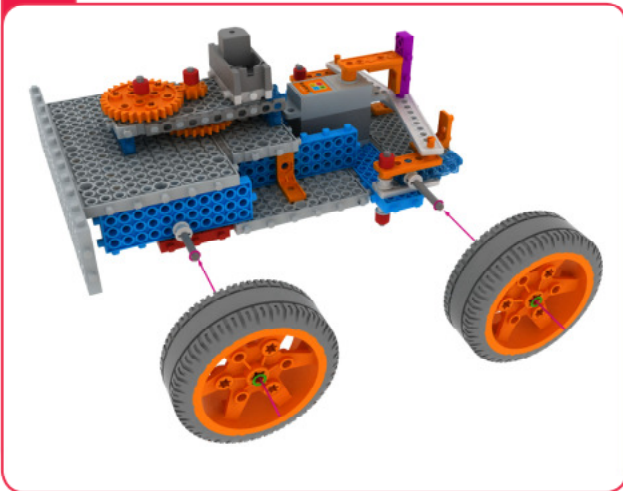

28

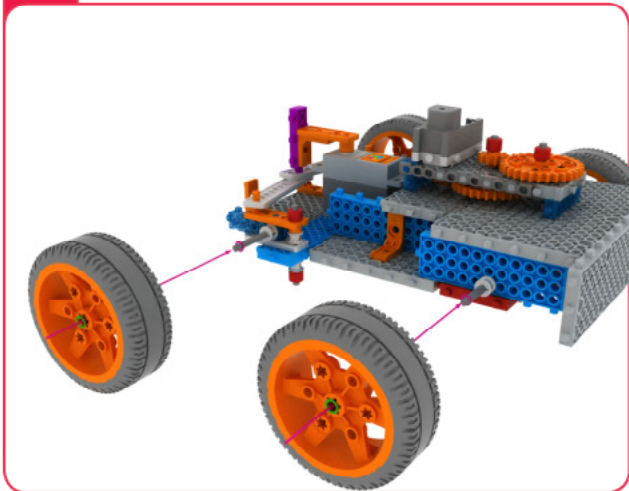

29

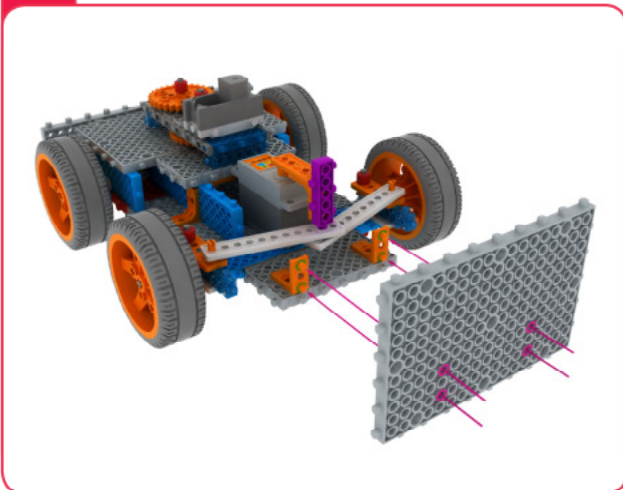

30

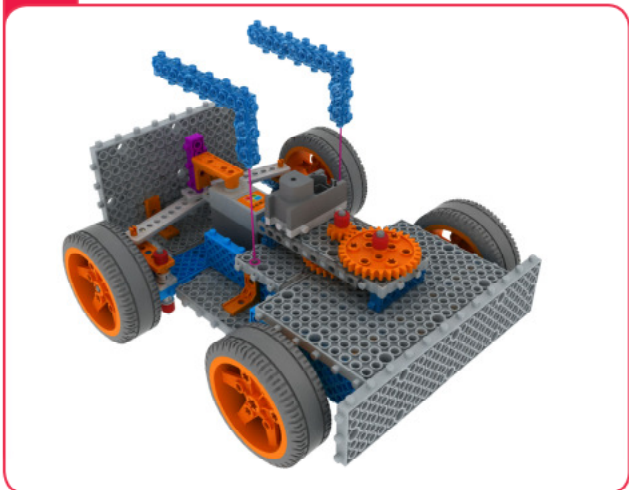

31

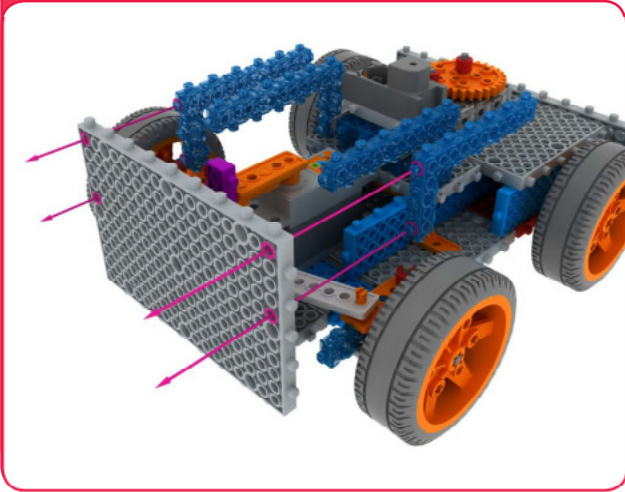

32

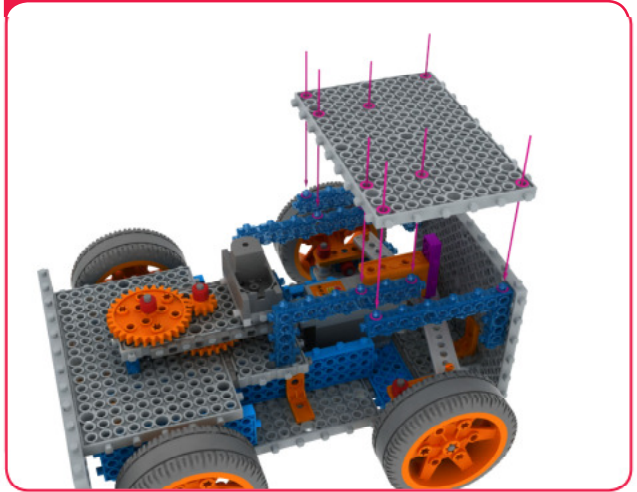

33

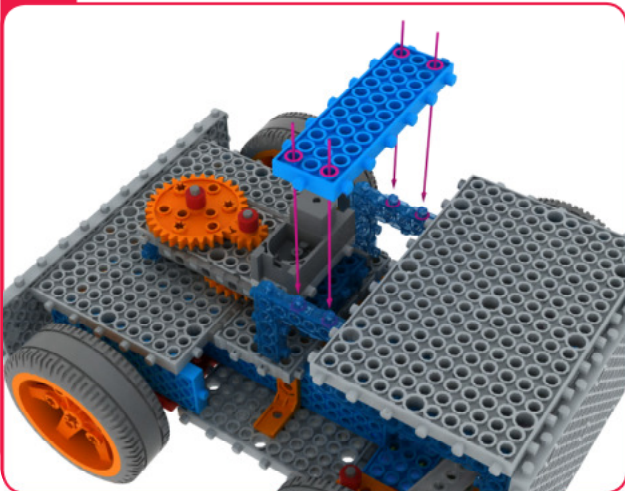

34

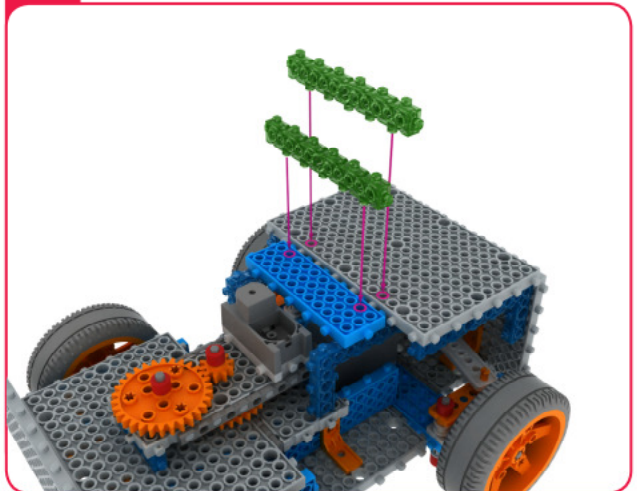

35

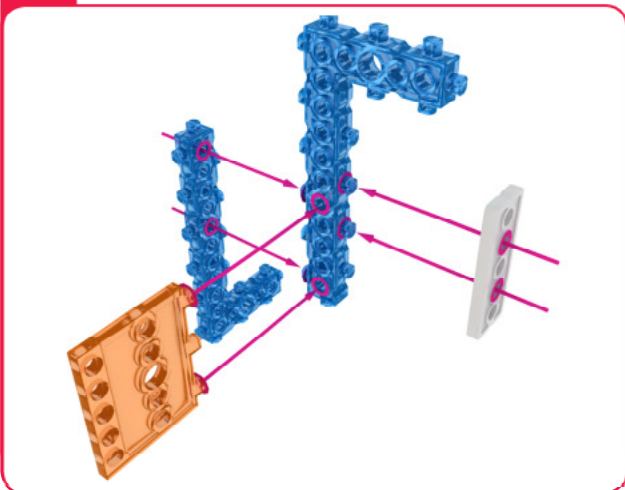

36

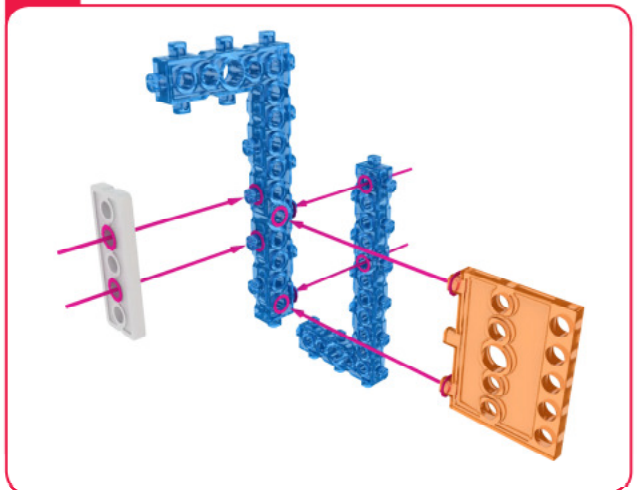

37

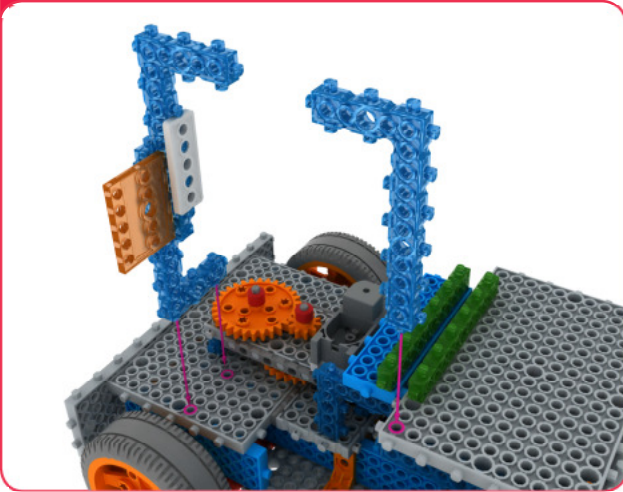

38

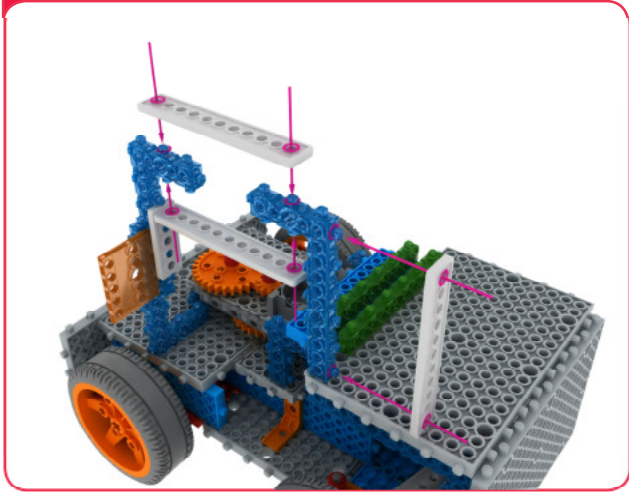

39

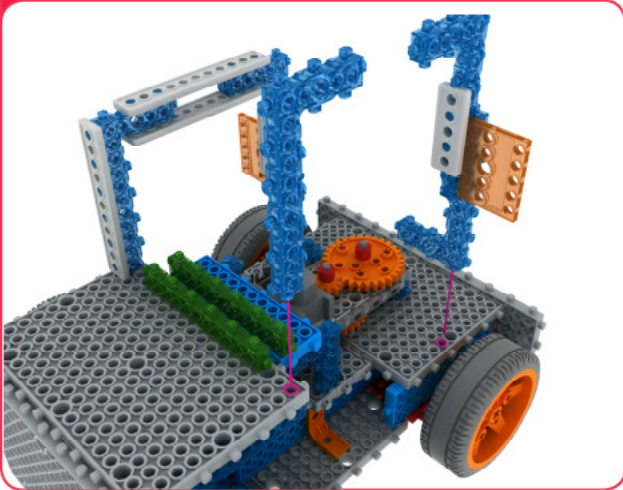

40

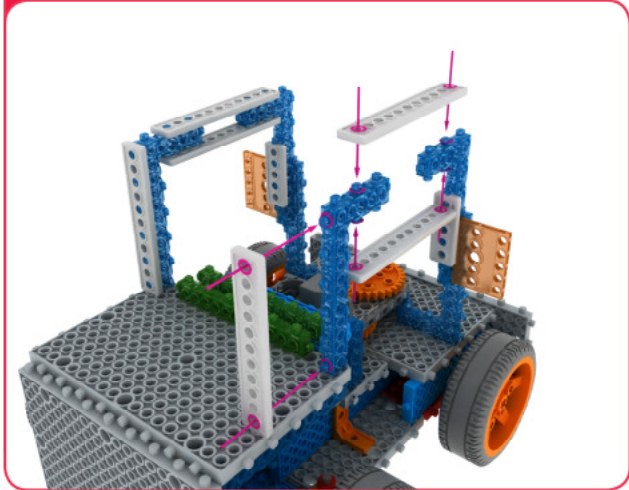

41

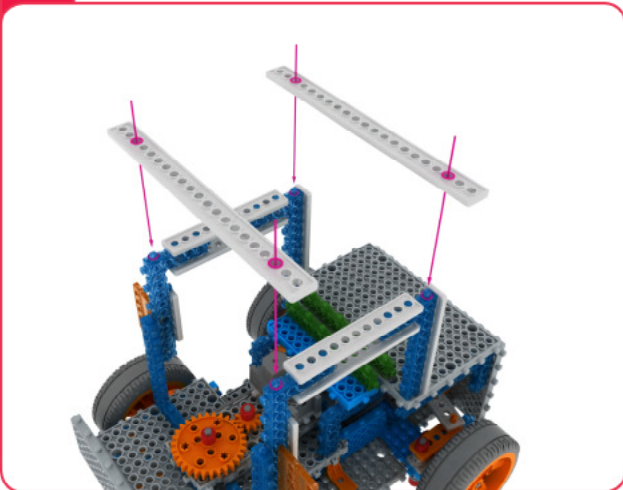

42

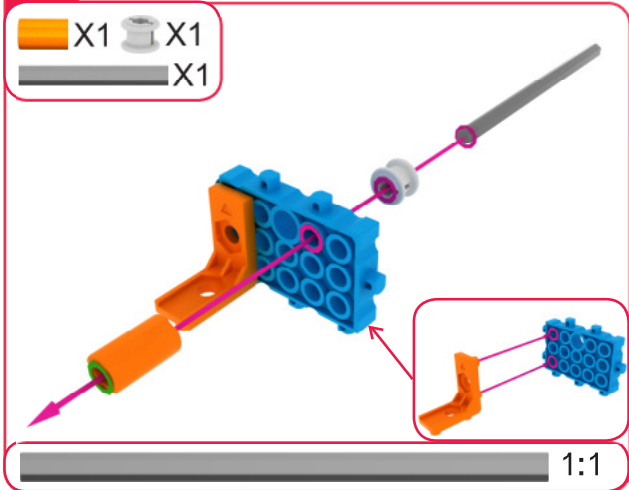

43

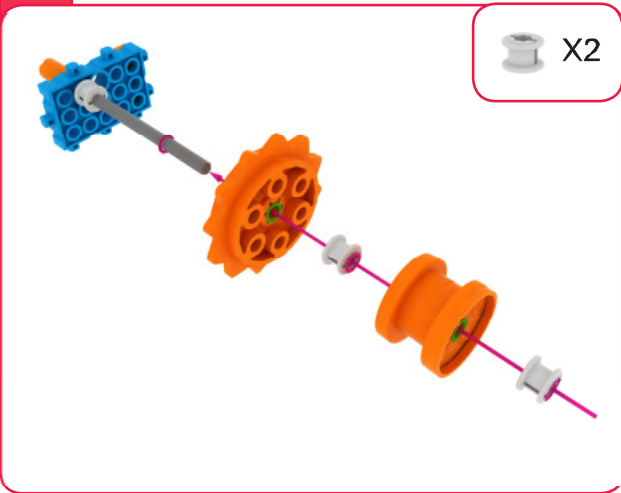

44

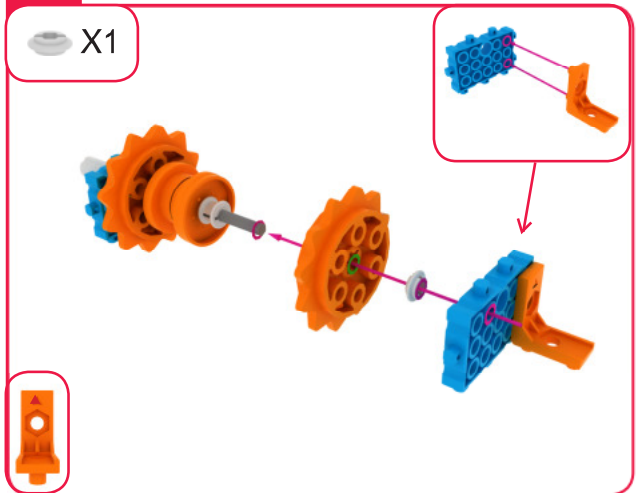

45

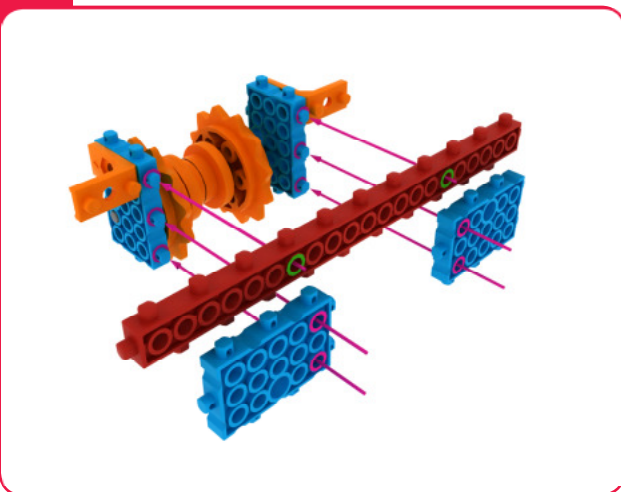

46

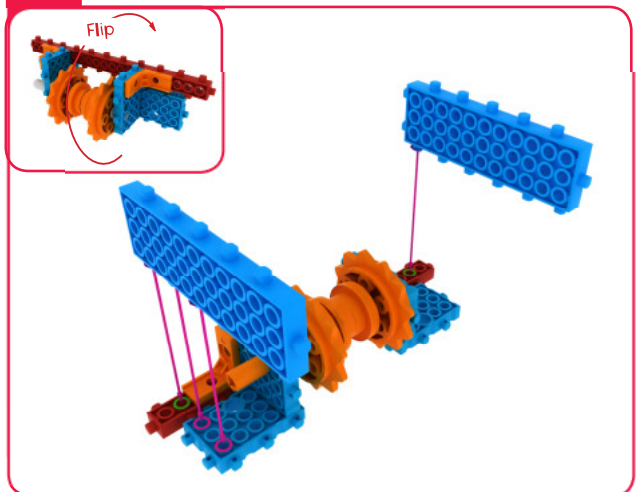

47

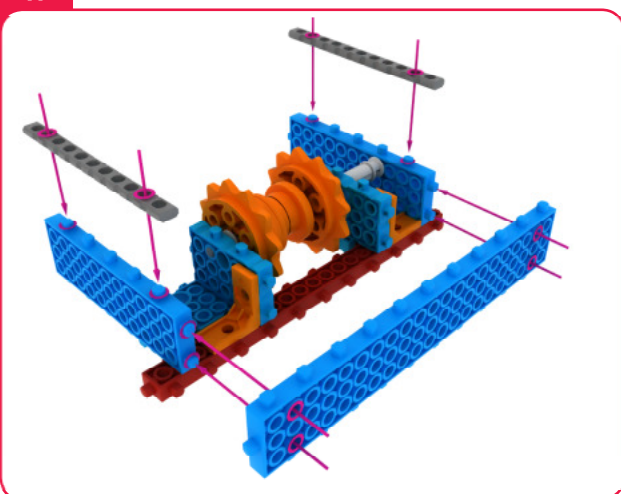

48

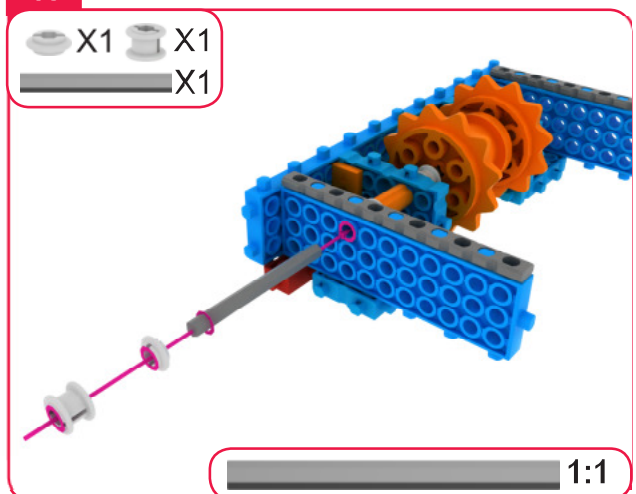

49

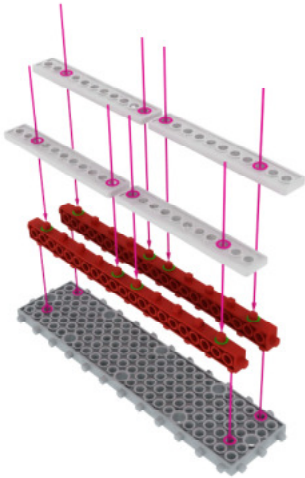

50

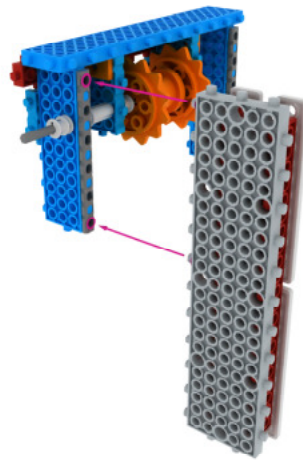

51

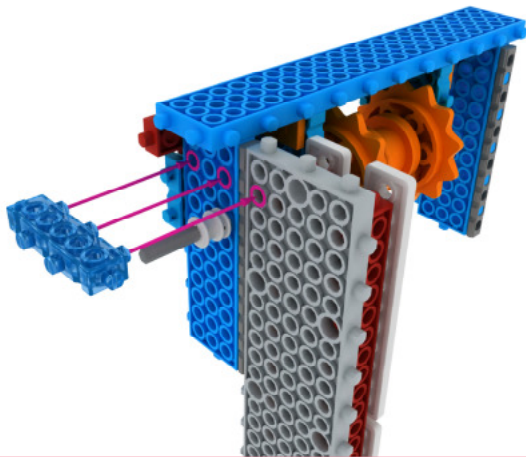

52

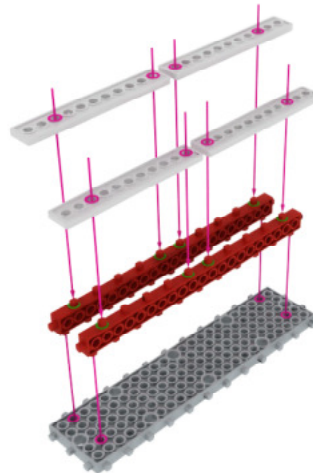

53

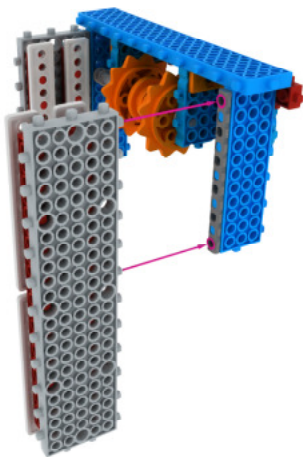

54

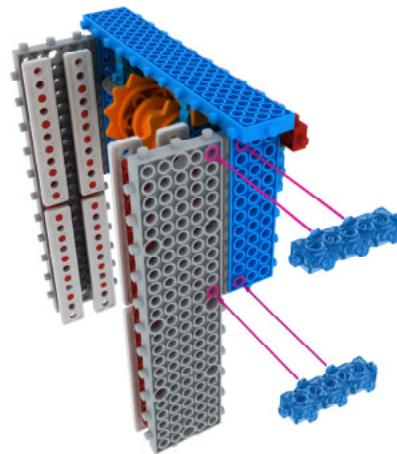

61

X1

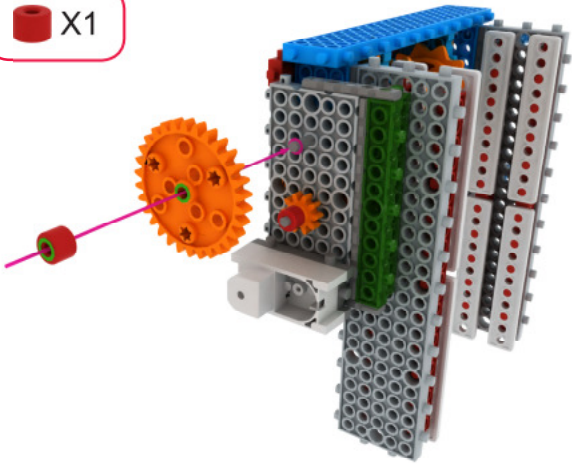

62

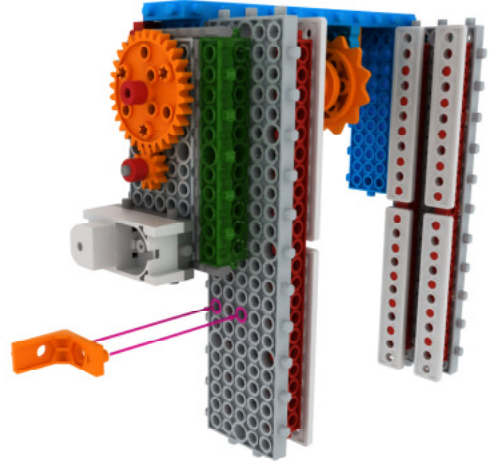

63

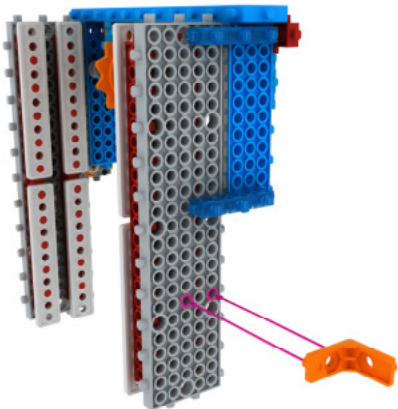

64

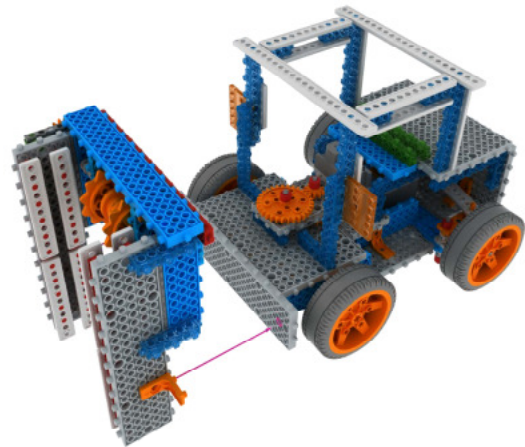

65

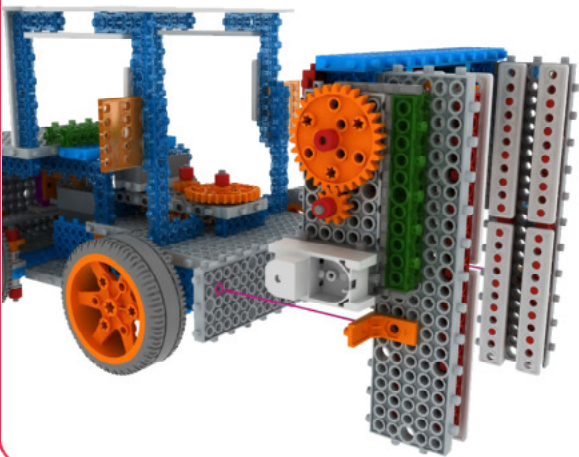

66

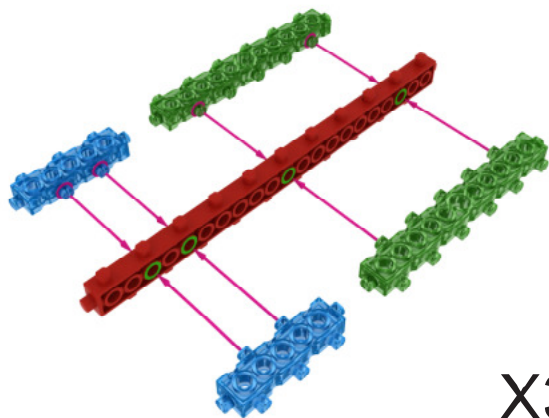

X3

67

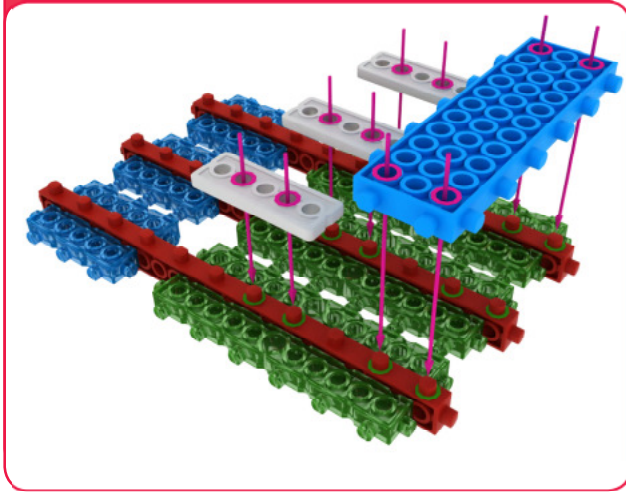

68

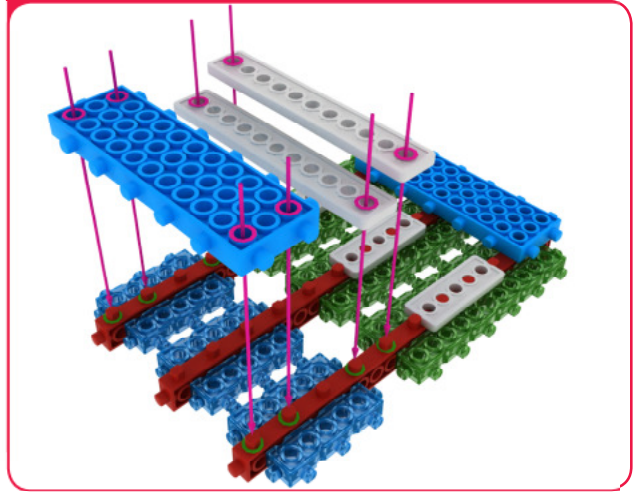

69

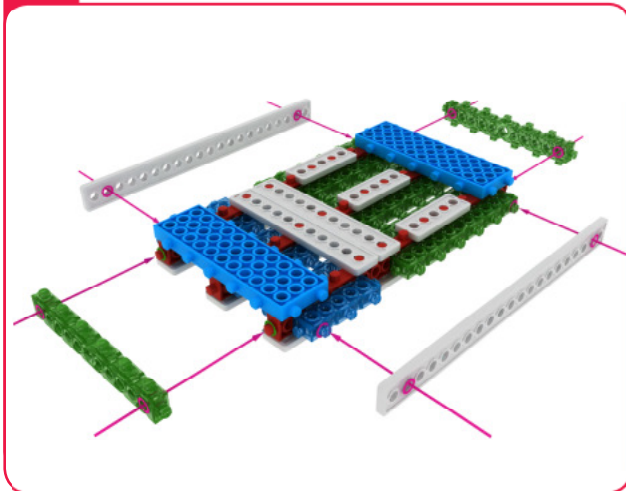

70

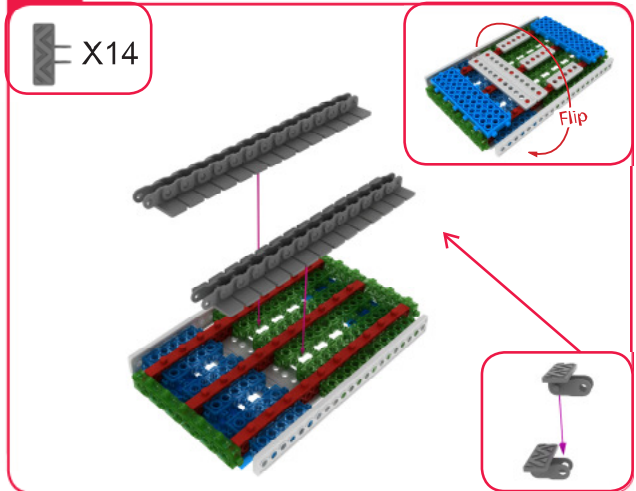

71

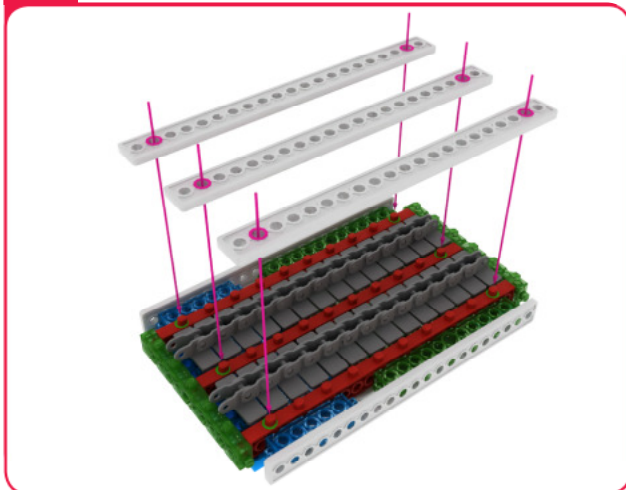

72

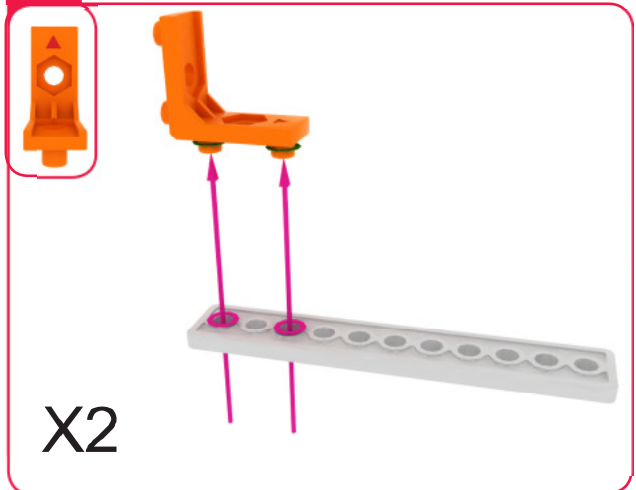

73

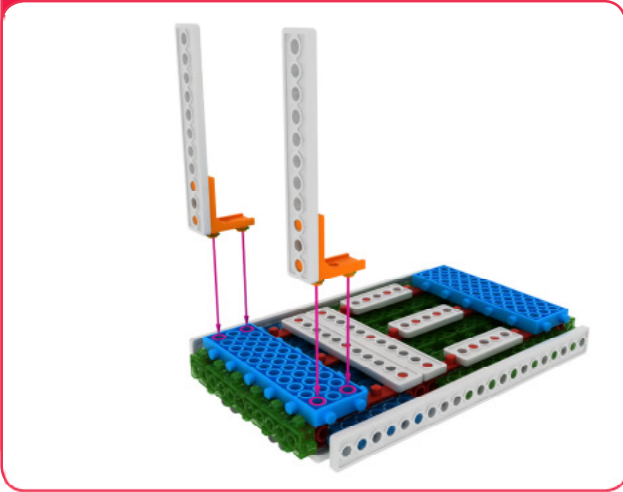

74

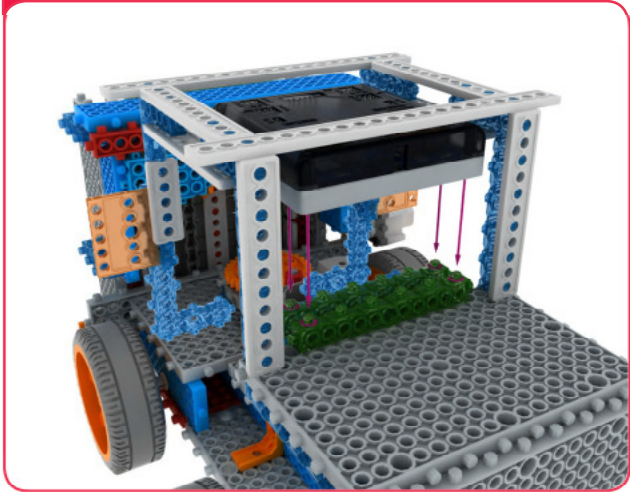

75

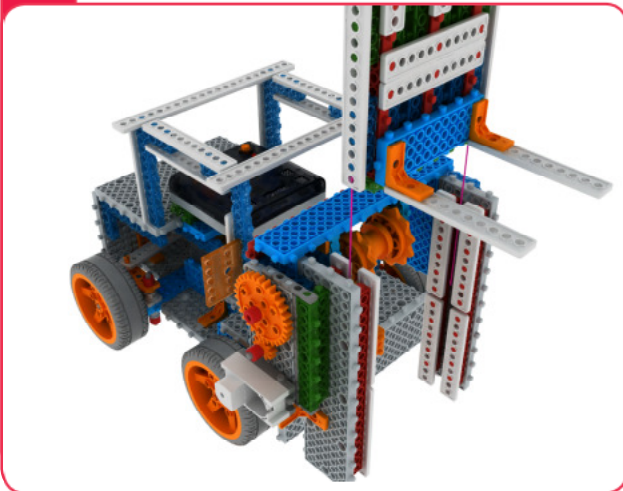

76

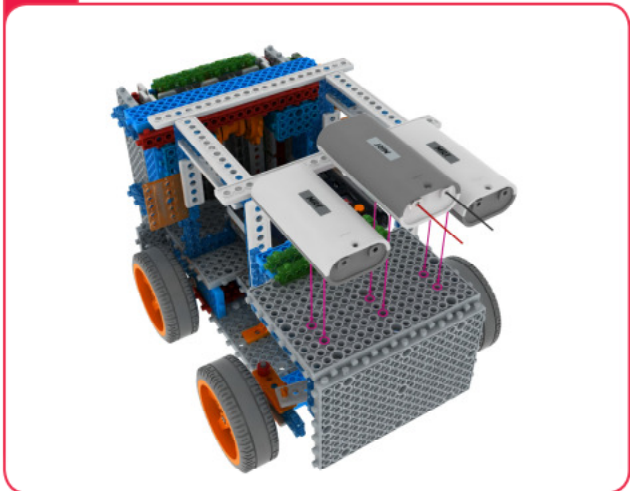

77

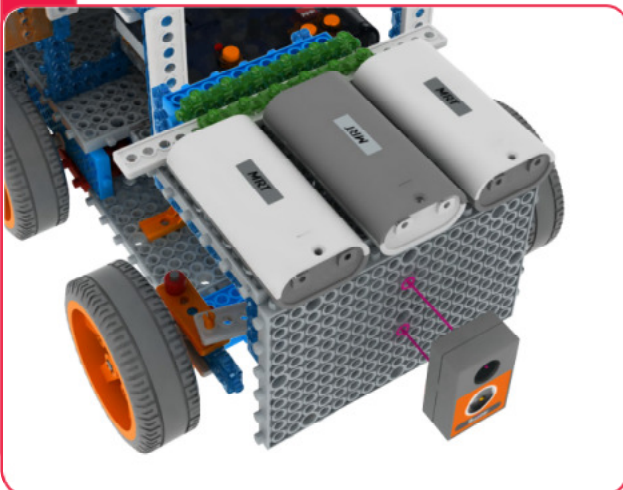

End

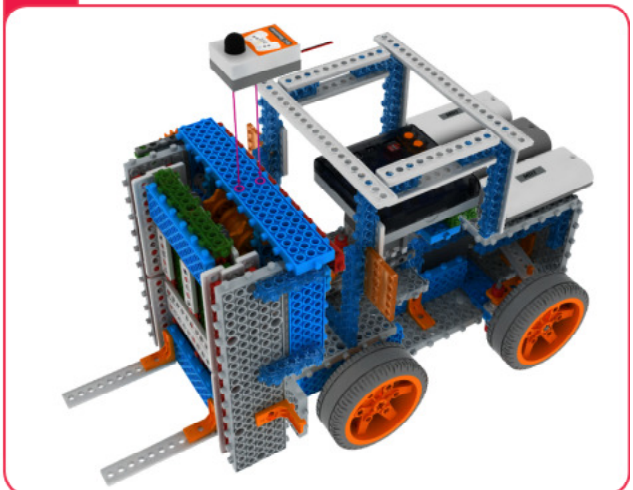

How to operate the Fork lift

Connecting the main board

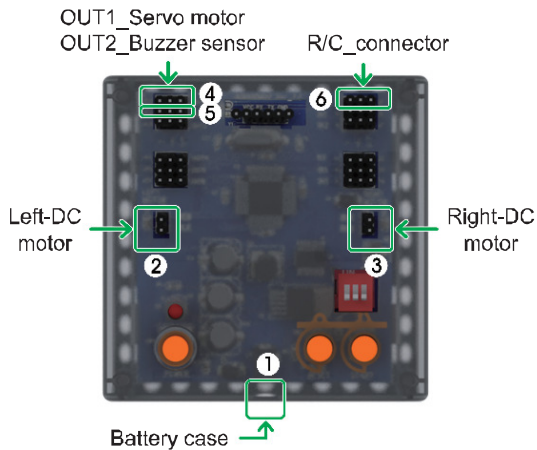

Connect in this order.

1. Connect Battery Cases to Power connector.
2. Connect Left-DC motor to Left-motor connector.
3. Connect Right-DC motor to Right-motor connector.
4. Connect Servo motor to OUT1 of OUTPUT connector.
5. Connect Buzzer sensor to OUT2 of OUTPUT connector.
6. Connect RC receiver board to R/C connector.

Motion Pattern/Program

Remocon key	DC Motor	Servo Motor
Up	L-Motor Forward	0degree
Down	L-Motor Backward	0degree
Left	L-Motor Forward	-30degree
Right	L-Motor Forward	30degree
F1	R-Motor Backward Speed 5	
F2	R-Motor Forward Speed 5	
KEY OFF	Both Motor Stop	

- F1
- LIFT UP

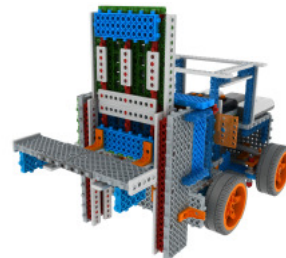

- F4
- LIFT DOWN

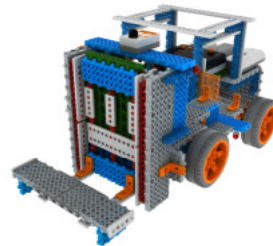

※ Using the motion patterns as reference, let's write the program.

Program Download

1. Write the program.
2. Make sure Power / DC Motor connector and sensor's connector are well connected.
3. Check the power OFF state, then insert the download cable.
4. 'SAVE' and click the 'DOWNLOAD' button on the program window.
5. Turn on the power when 'DOWNLOAD' window opens. (Power ON)
6. Once the download is completed, remove the download cable and then turn the power off and on. (Power OFF → Power ON)

Program Example 1

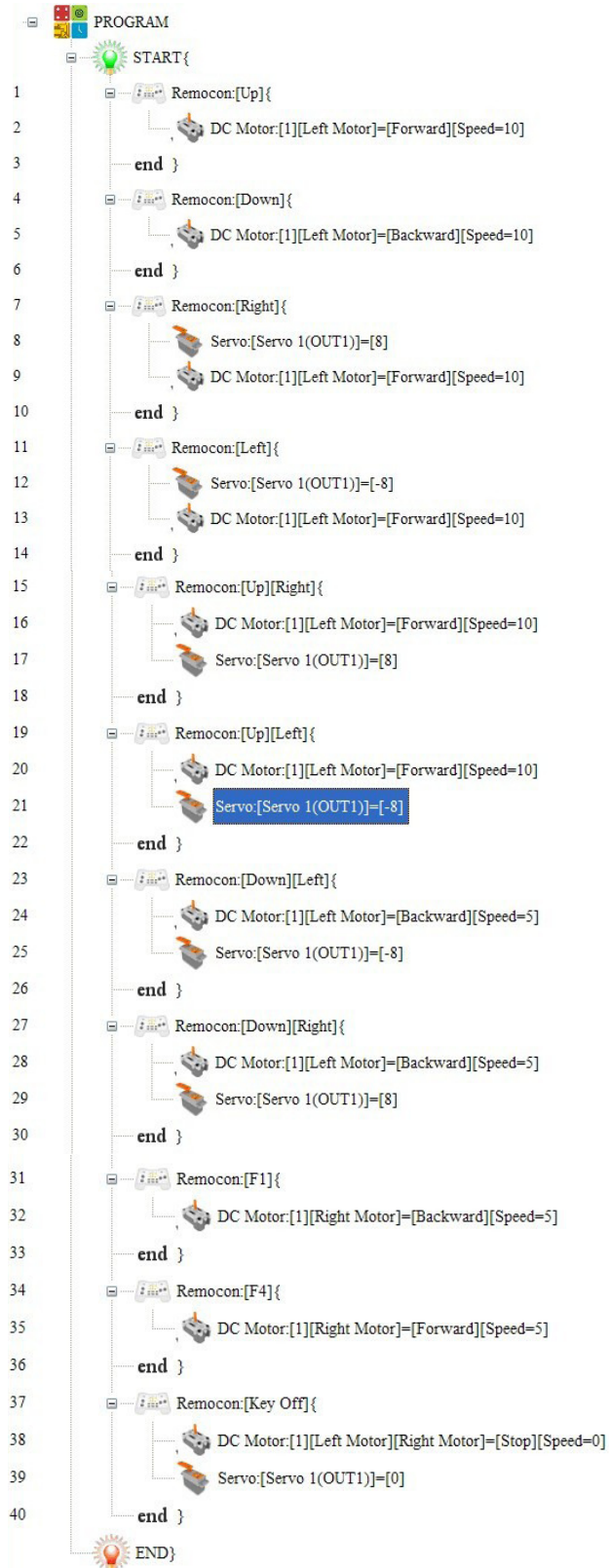



Technology Art Carry the object using the Forklift tables Using the lift robot

Table

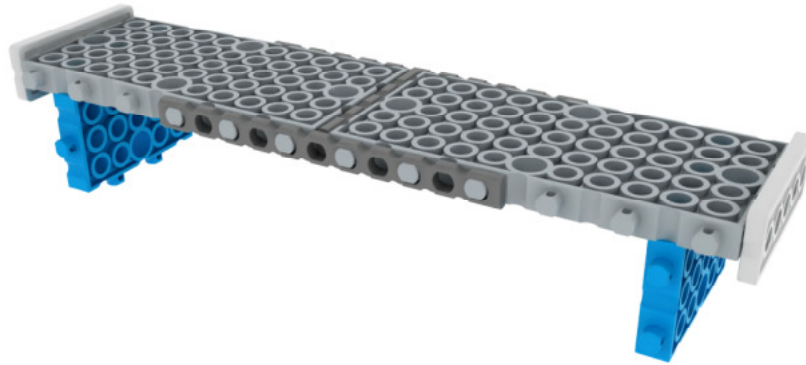

※ Make the table with the rest blocks.

Start

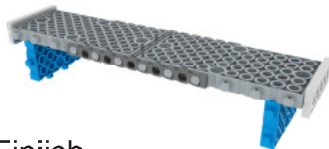
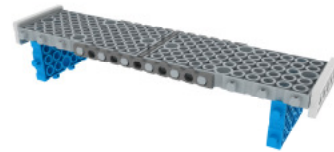

Finish

※ Play the game with two group.

TIP. In real, when the fork lift backward, it comes out some sound to remind people. Let's make a program the remind melody with buzzer sensor.

Program Example 2

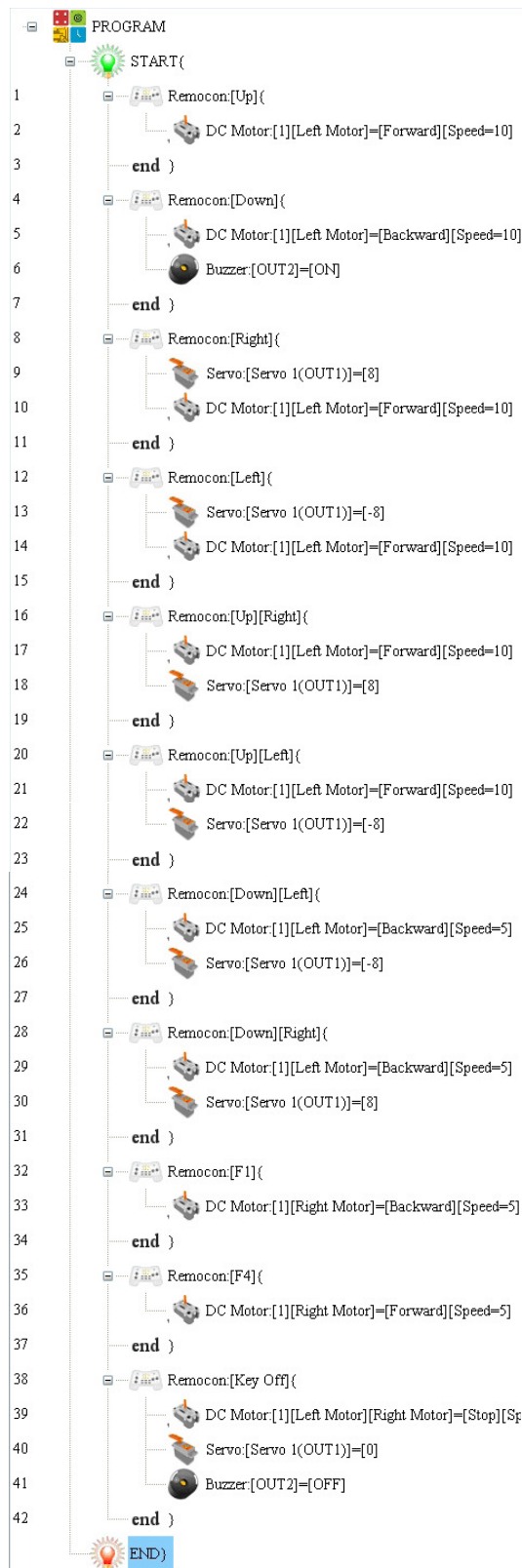



Technology

STEM 14. Systems that use AI

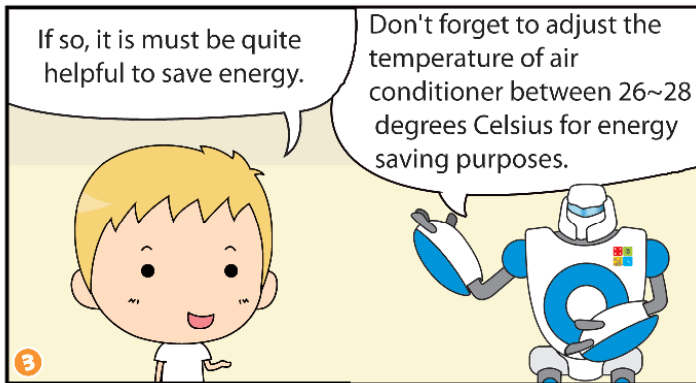
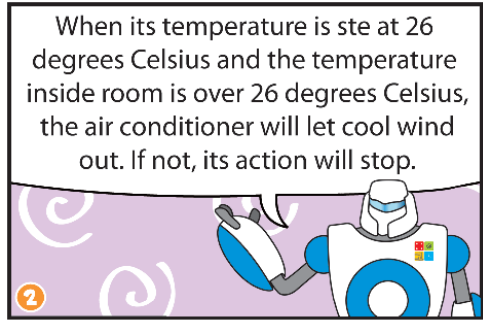
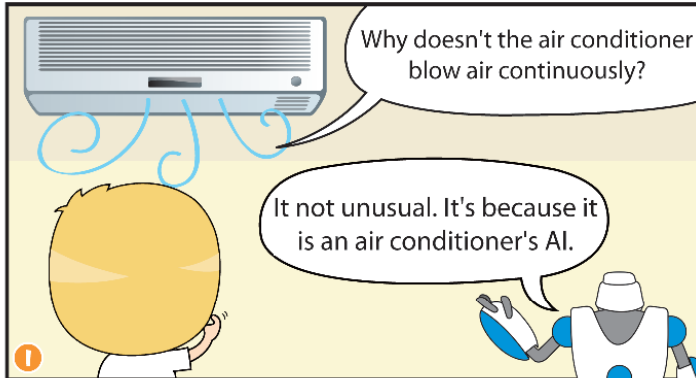

Spiral notebook with 15 horizontal lines for writing.

T Technology **STEM 15. Robot simulating humans—AI 2 (Humanoid)**

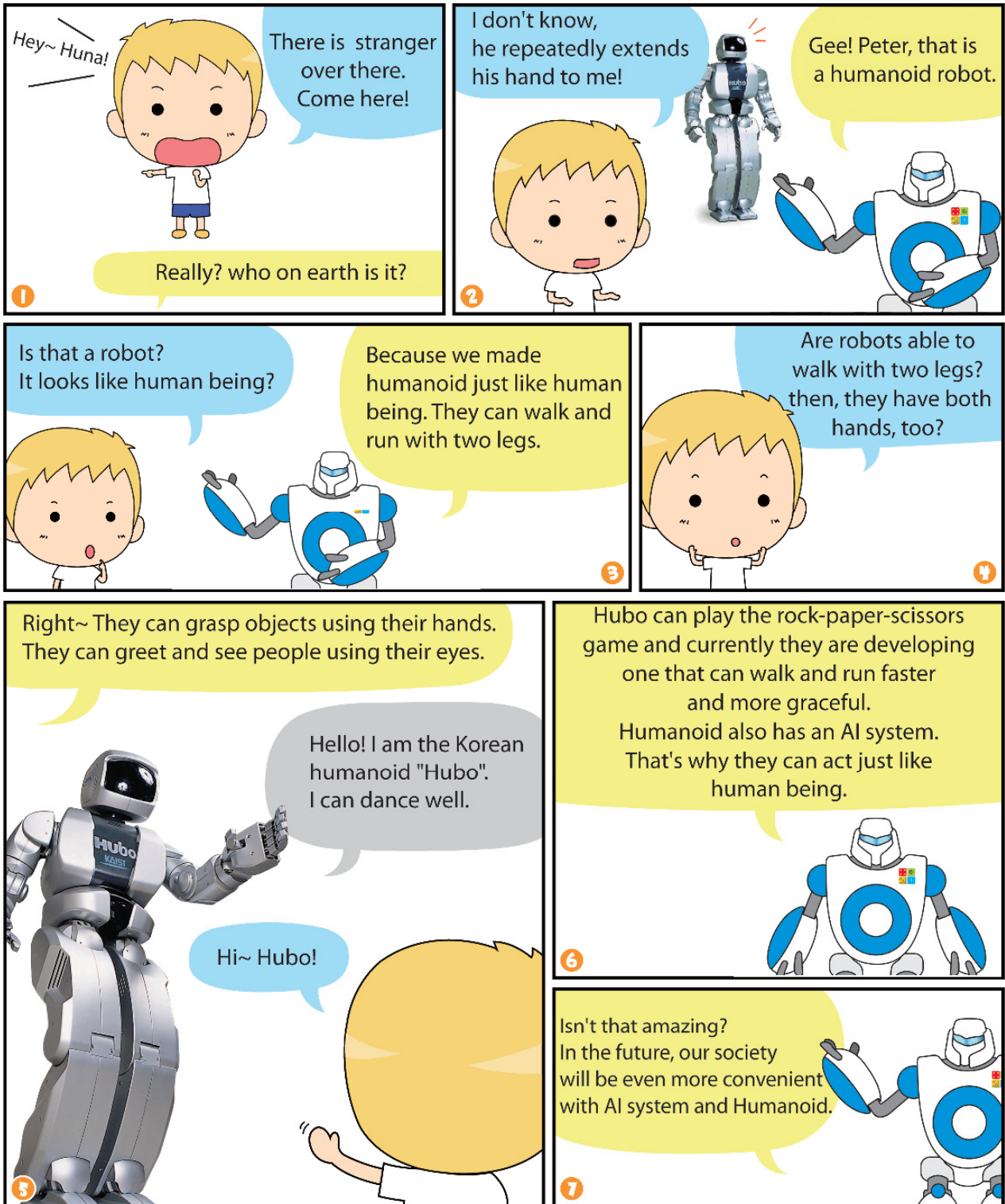



Engineering
Art

Robot Making 8-Bowling Robot



1

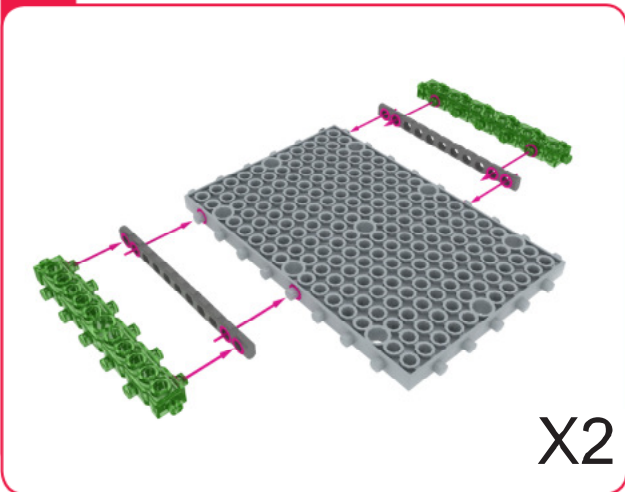

2

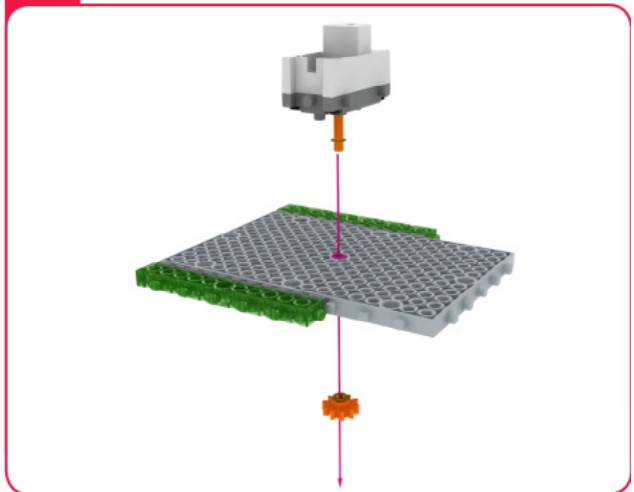

Advanced Level

3

 X2
 X1

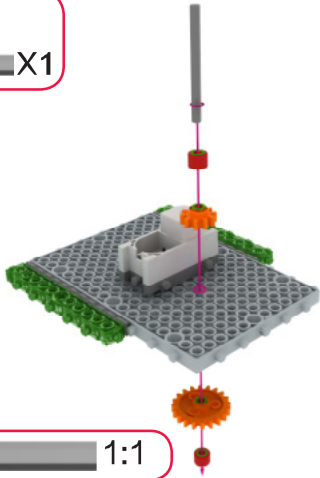

 1:1

4

 X1  X1

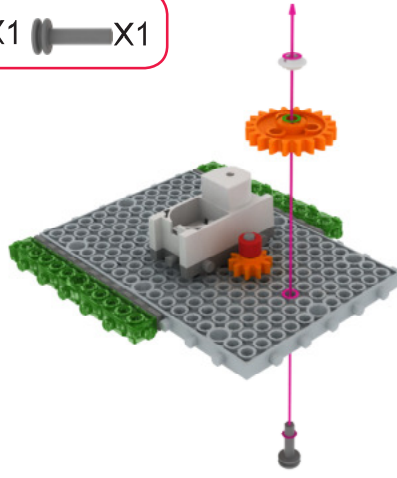

5

 X2
 X2

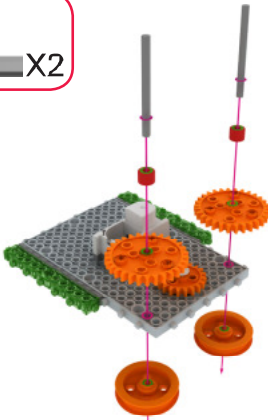

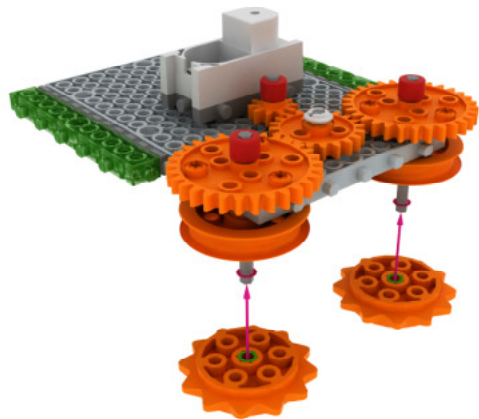

 1:1

6



7

 X2  X2  X2
 X2



 1:1

8

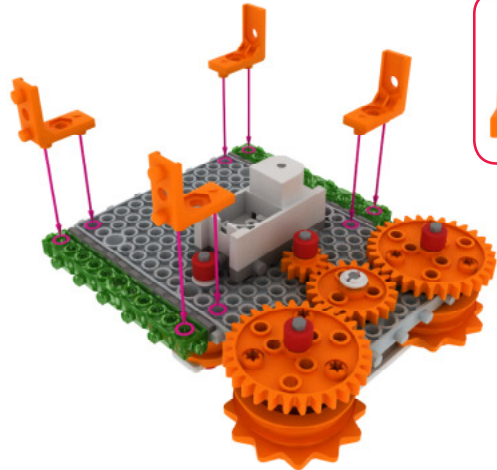

MY ROBOT TIME

9

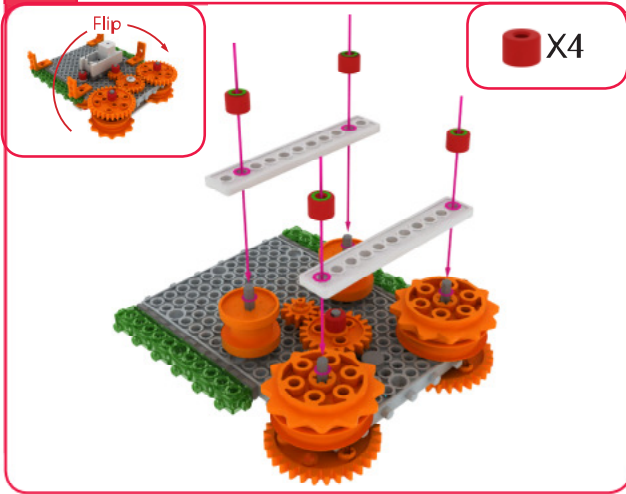

10

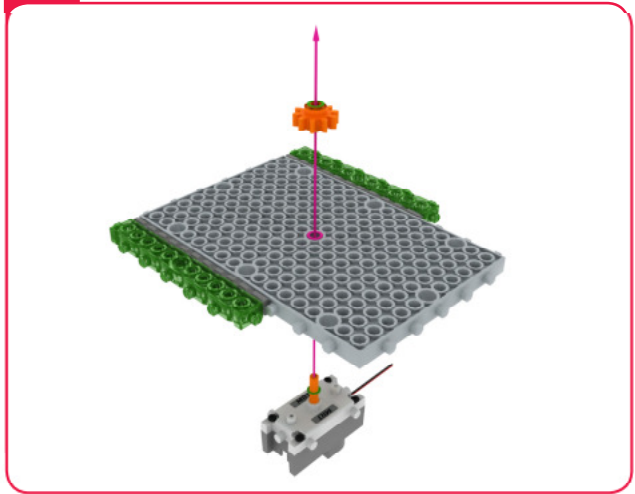

11

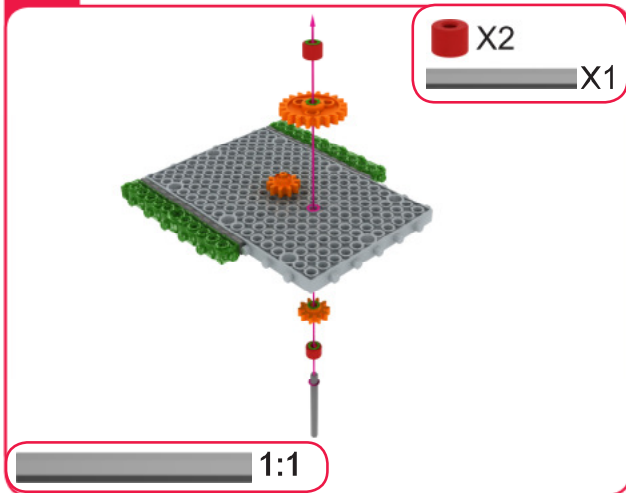

12

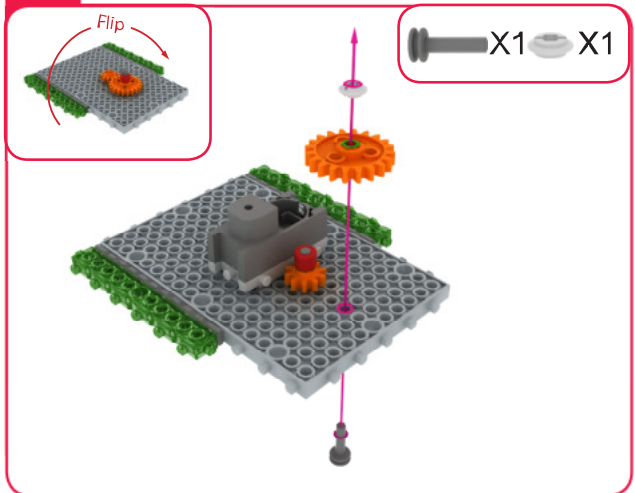

13

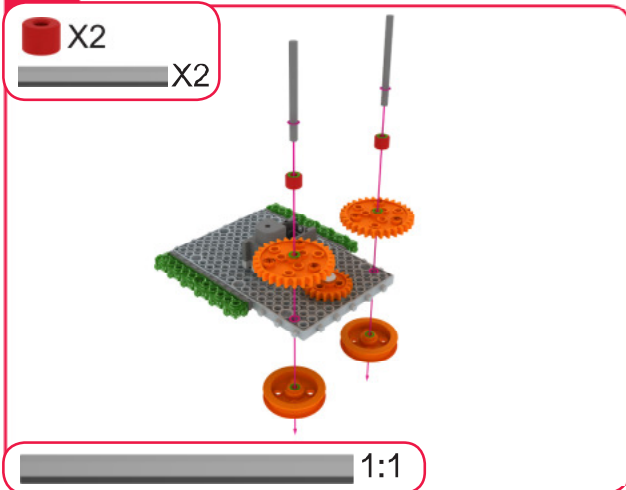

14

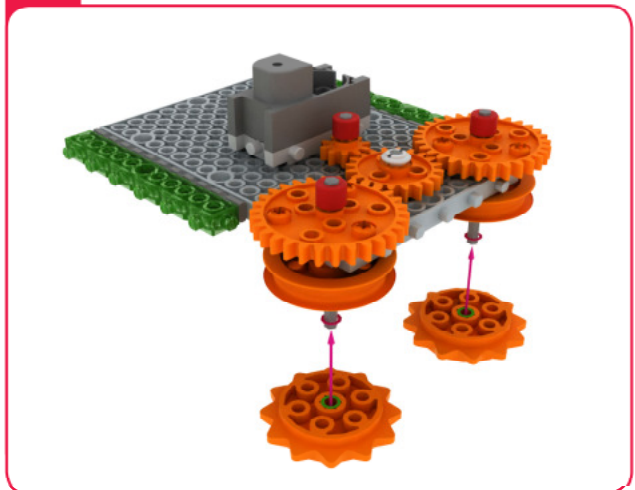

15

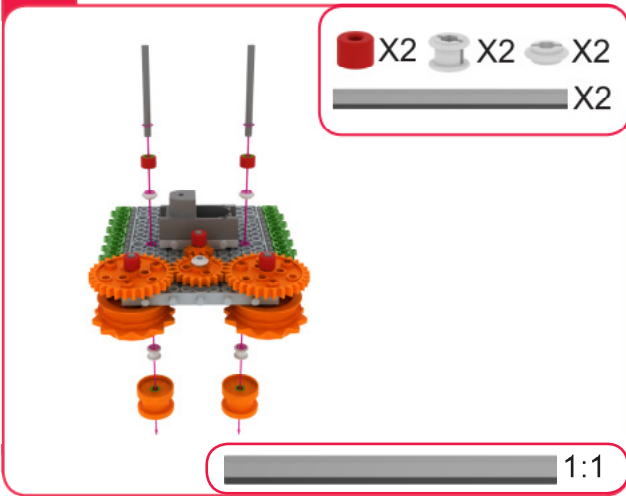

16

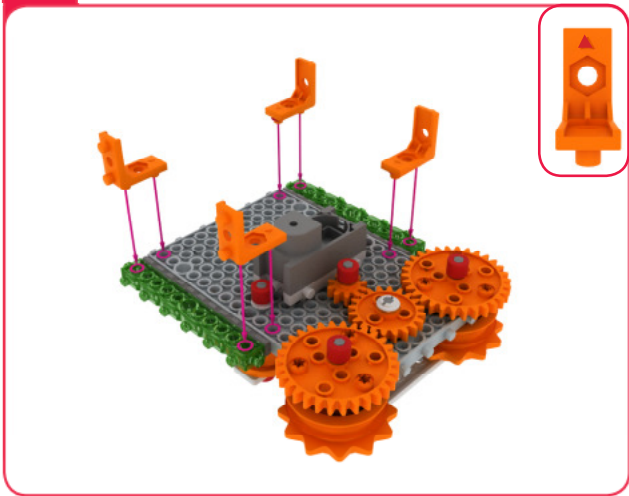

17

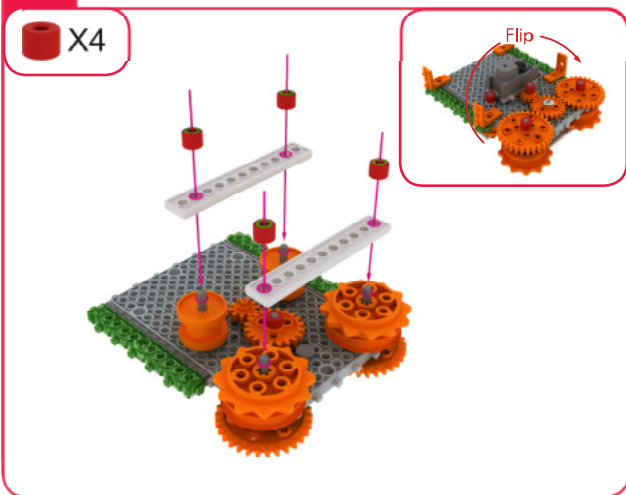

18

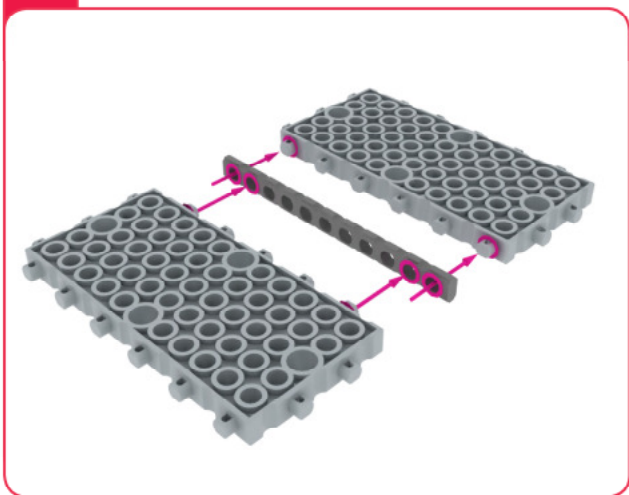

19

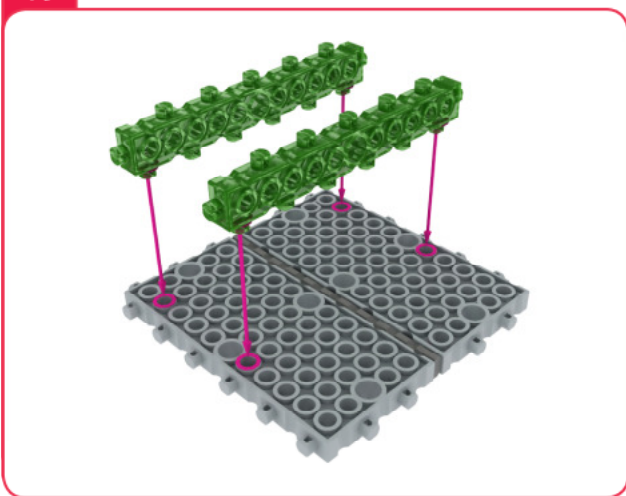

20

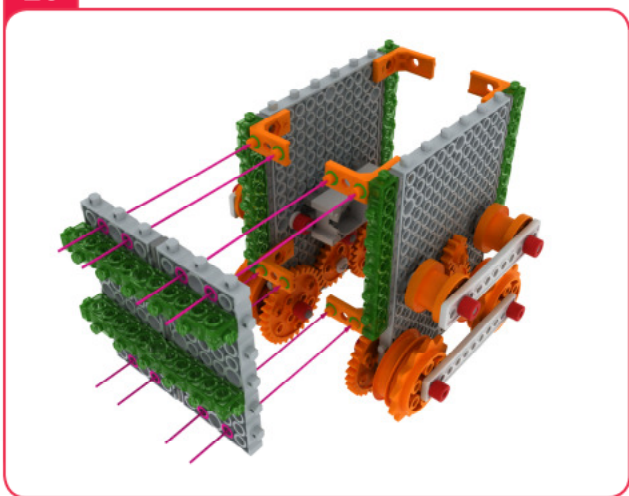

21

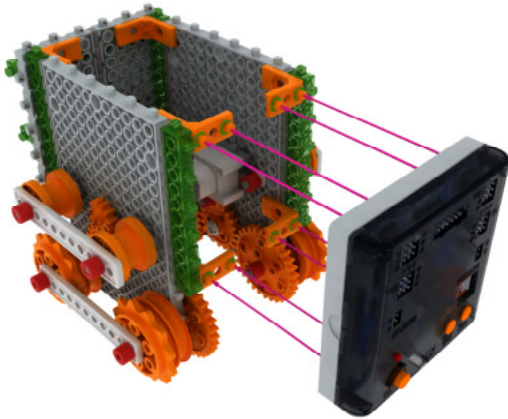

22

X31

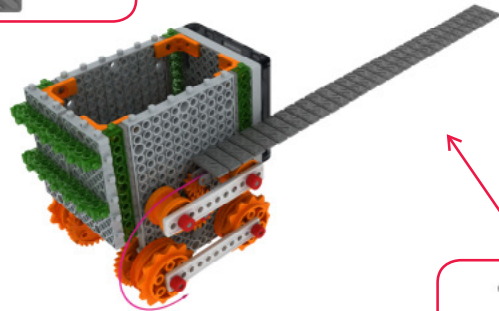

23

X31

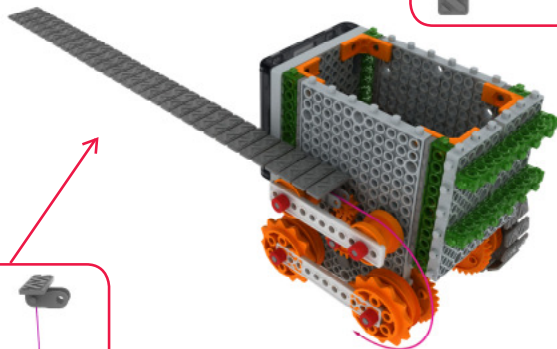

24

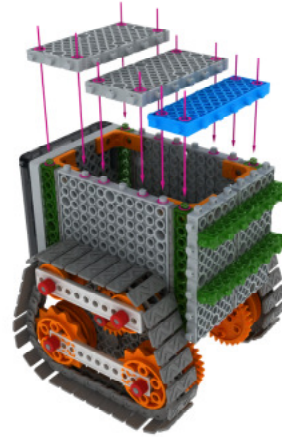

25

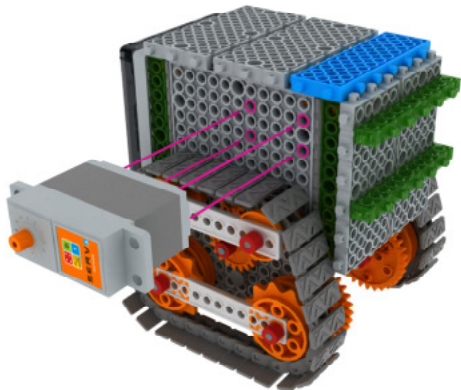

26

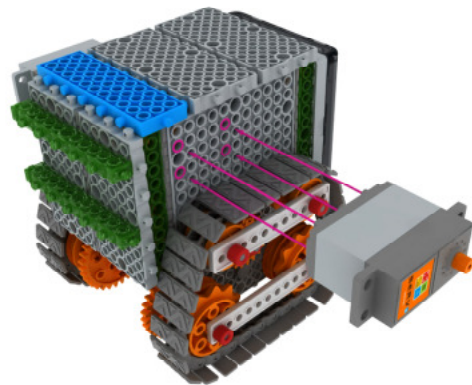

27

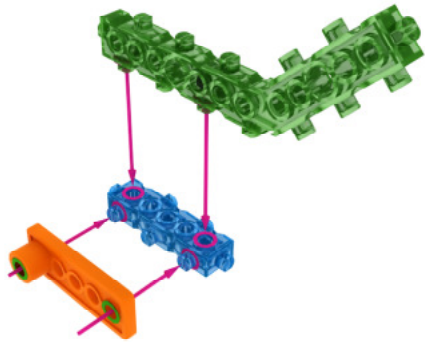

28

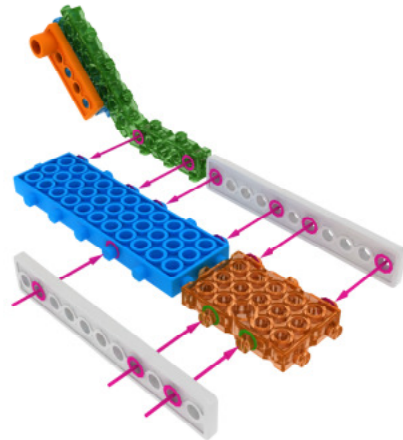

29

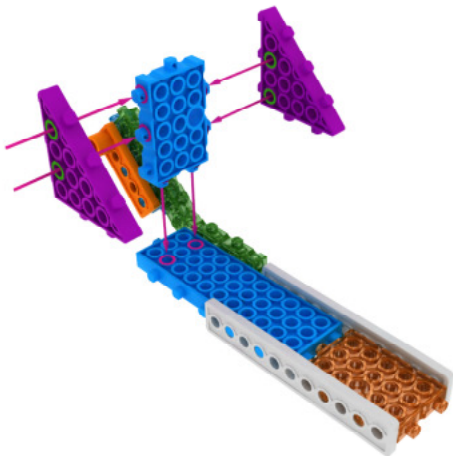

30

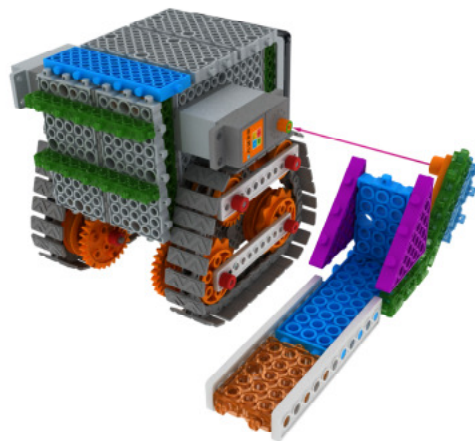

Servo Motor-Zero Point Adjustment

1. Connect the servo motor to the mainboard. You can write the program in the following way.

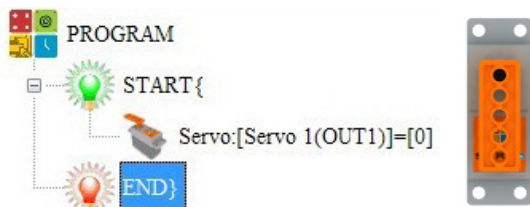

2. After downloading the program, power off and on again.
3. Fix servo motor horn to the servo motor with a small servo bolt as illustrated in the picture .

31

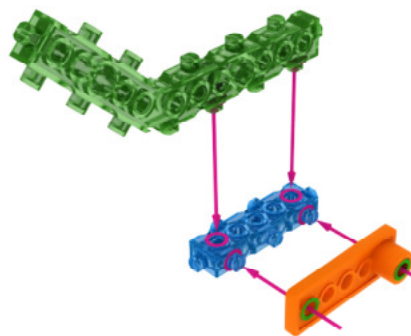

32

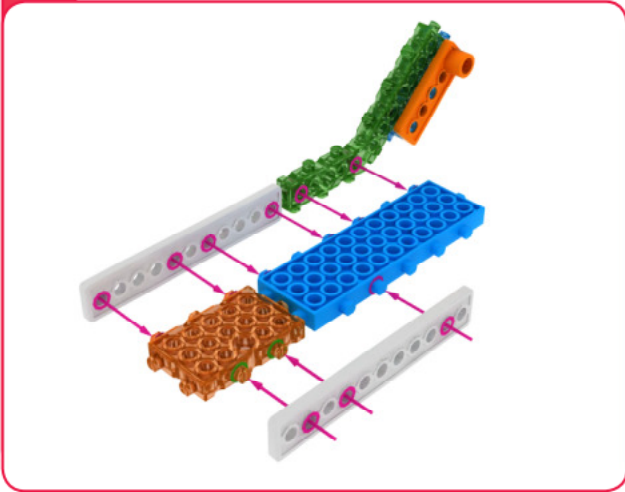

33

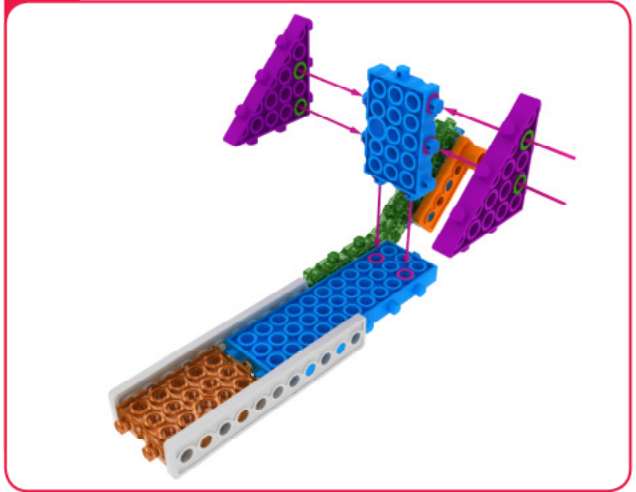

34

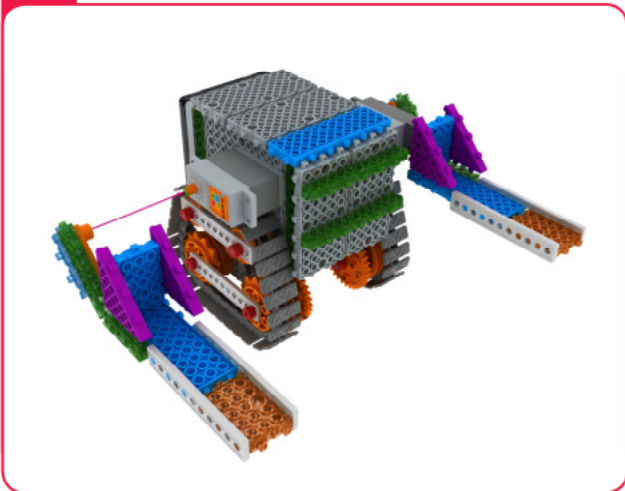

Servo Motor-Zero Point Adjustment

1. Connect the servo motor to the mainboard. You can write the program in the following way.

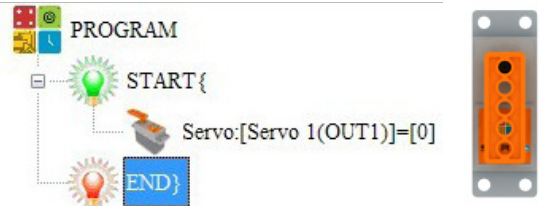

2. After downloading the program, power off and on again.
3. Fix servo motor horn to the servo motor with a small servo bolt as illustrated in the picture .

35

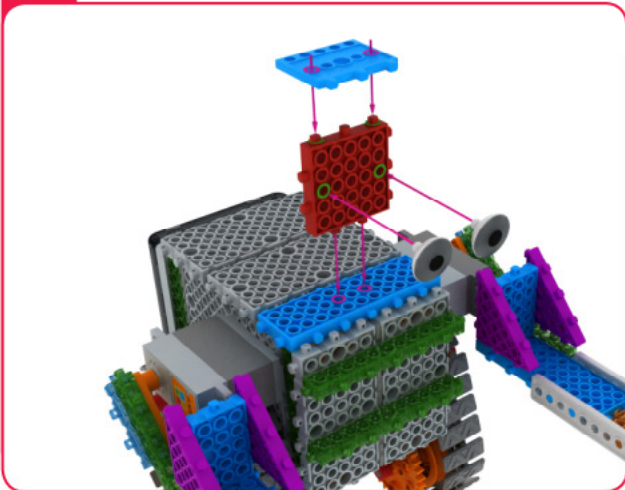

36

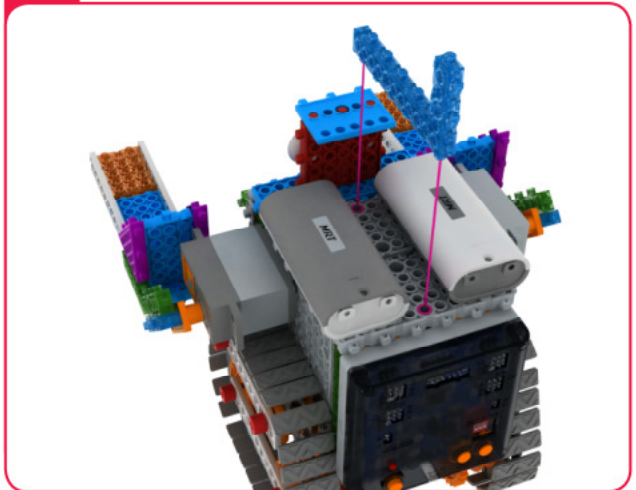

37

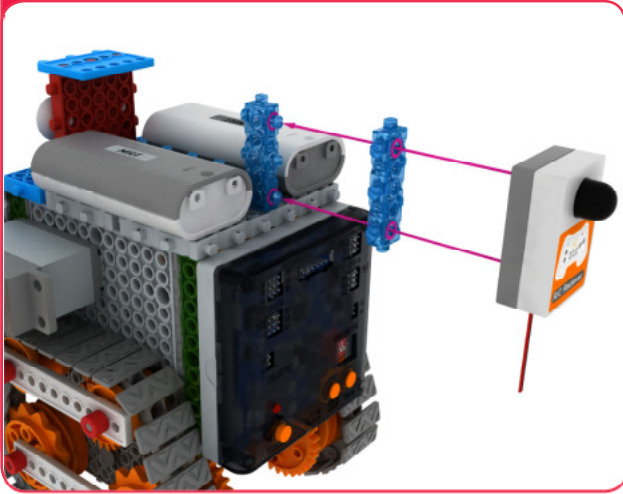

End





How to operate the Bowling robot

Connecting the main board

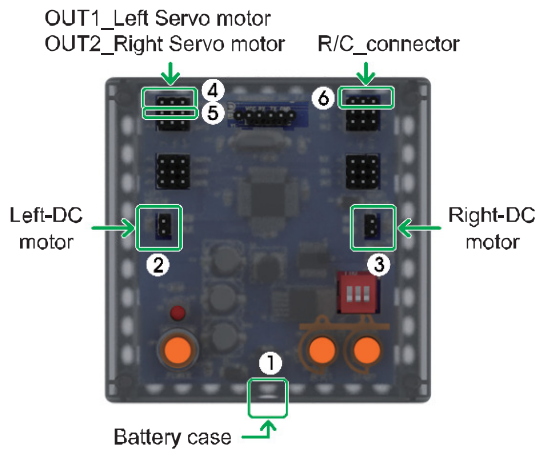

Connect in this order.

1. Connect Battery Cases to Power connector.
2. Connect Left-DC motor to Left-motor connector.
3. Connect Right-DC motor to Right-motor connector.
4. Connect Left Servo motor to OUT1 of OUTPUT connector.
5. Connect Right Servo motor to OUT2 of OUTPUT connector.
6. Connect RC receiver board to R/C connector.

Motion Pattern/Program

- F1: Left hand (Put down and up)
- F2: Right hand (Put down and up)

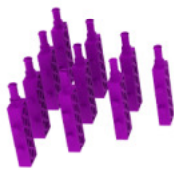

※ Using the motion patterns as reference, let's write the program.

Program Download

1. Write the program.
2. Make sure Power / DC Motor connector and sensor's connector are well connected.
3. Check the power OFF state, then insert the download cable.
4. 'SAVE' and click the 'DOWNLOAD' button on the program window.
5. Turn on the power when 'DOWNLOAD' window opens. (Power ON)
6. Once the download is completed, remove the download cable and then turn the power off and on.
(Power OFF → Power ON)

Program Example

```

PROGRAM
START {
1  Remocon:[Up]{
2     DC Motor:[1][Left Motor][Right Motor]=[Backward][Speed=10]
3  end }
4  Remocon:[Down]{
5     DC Motor:[1][Left Motor][Right Motor]=[Forward][Speed=10]
6  end }
7  Remocon:[Left]{
8     DC Motor:[1][Left Motor]=[Forward][Speed=10]
9     DC Motor:[1][Right Motor]=[Backward][Speed=10]
10 end }
11 Remocon:[Up][Left]{
12    DC Motor:[1][Left Motor]=[Stop][Speed=0]
13    DC Motor:[1][Right Motor]=[Backward][Speed=10]
14 end }
15 Remocon:[Right]{
16    DC Motor:[1][Left Motor]=[Backward][Speed=10]
17    DC Motor:[1][Right Motor]=[Forward][Speed=10]
18 end }
19 Remocon:[Up][Right]{
20    DC Motor:[1][Left Motor]=[Backward][Speed=10]
21    DC Motor:[1][Right Motor]=[Stop][Speed=0]
22 end }
23 Remocon:[F1]{
24    Servo:[Servo 2(OUT2)]=[60]
25    Delay:[1.5 sec]
26    Servo:[Servo 2(OUT2)]=[0]
27 end }
28 Remocon:[F3]{
29    Servo:[Servo 1(OUT1)]=-60]
30    Delay:[1.5 sec]
31    Servo:[Servo 1(OUT1)]=[0]
32 end }
33 Remocon:[Key Off]{
34    DC Motor:[1][Left Motor][Right Motor]=[Stop][Speed=0]
35    Servo:[Servo 1(OUT1)]=[0][Servo 2(OUT2)]=[0]
36 end }
END}
    
```

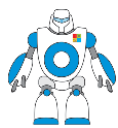
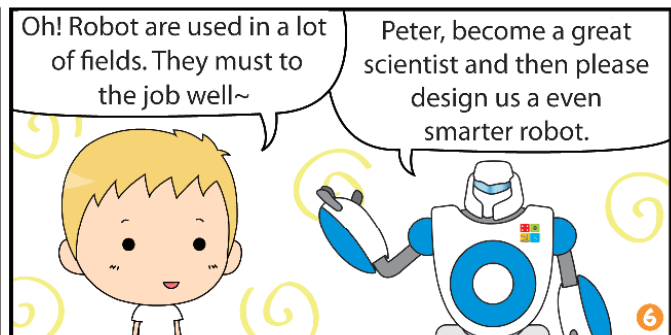
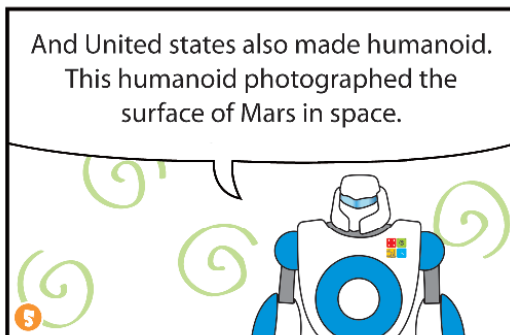
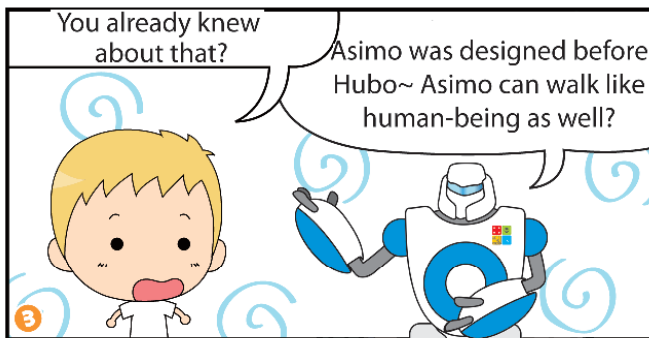
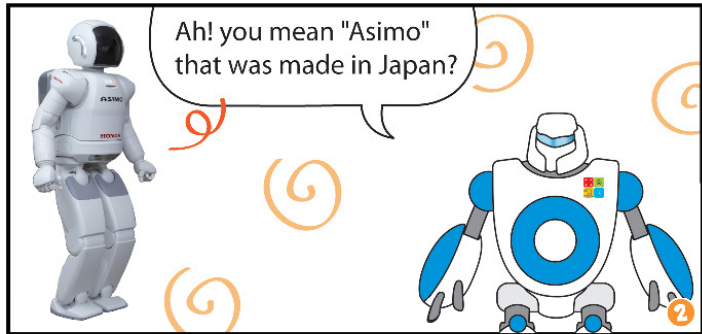
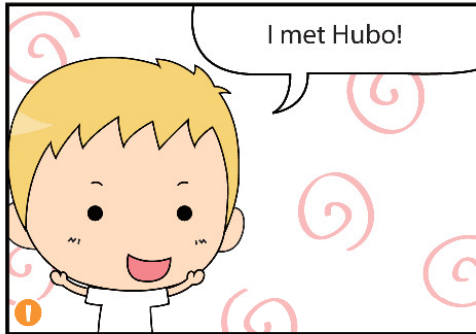

Let's compare Hubo with Asimo after reading a news item about humanoid!

● Hubo and Asimo

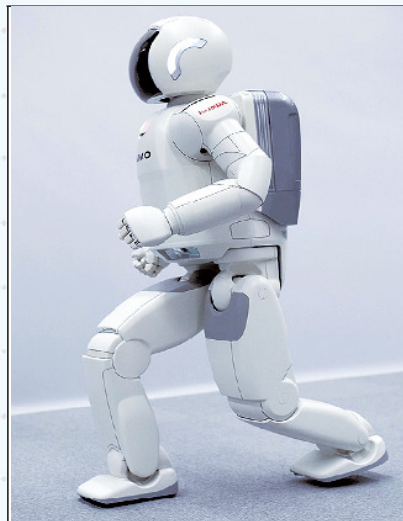

Hubo	Name	Asimo
December, 2004	Birth Date	November, 2000
KAIST	Developer	HONDA, Japan
3 years	Period of development	15 years
About one billion won	Cost of development	About 3 hundred billion Won
120cm	Height	120cm
55kg	weight	43kg
41	Number of motorised Joints	26
Able to move 5 motors respectively	Motion of fingers	Able to move 5 motors at a time
Built -in battery in chest	Battery	Knapsack exterior battery
Speed of 1.2kph	Walking Speed	Speed of 1.6kph
Impossible	Driving Speed	3km for new-model



Technology

**STEM 17. Rules to follow-
Robotic Ethics**

1 Huna! Have you seen the film "I Robot"? I am afraid that such a thing might happen.

That's the film where robots attack people, right?

Yeah! The robots wanted to dominate the people.

2

Robotic Ethics? Is there such a thing?

Don't worry about that. There is a clearly defined code of ethics for robots to prevent such things from happening to us.

As you know, they are developing a new range of smart robots these days. For example, cleaning robot and even singing robot?

Yes, I saw that on TV.

3

If so, is there still a small chance of robots actually attacking people?

Certainly not!! Only if people make robots with ill intentions, will there be a chance of robots attacking people.

So, a promise was made to make sure people and smart robot will get along with each other.

4

No way~ All robot developers should follow these ethical guidelines.

I hope our society will be a place where robots and people will be able to live harmoniously together by following it well.

You're right! There are articles for robot as well as for developer. There will always be the possibility of people developing robot with ill intentions, so well need to set up standards for developers.

5

6

7

 **Engineering Art** **Robot Making9-TANK**

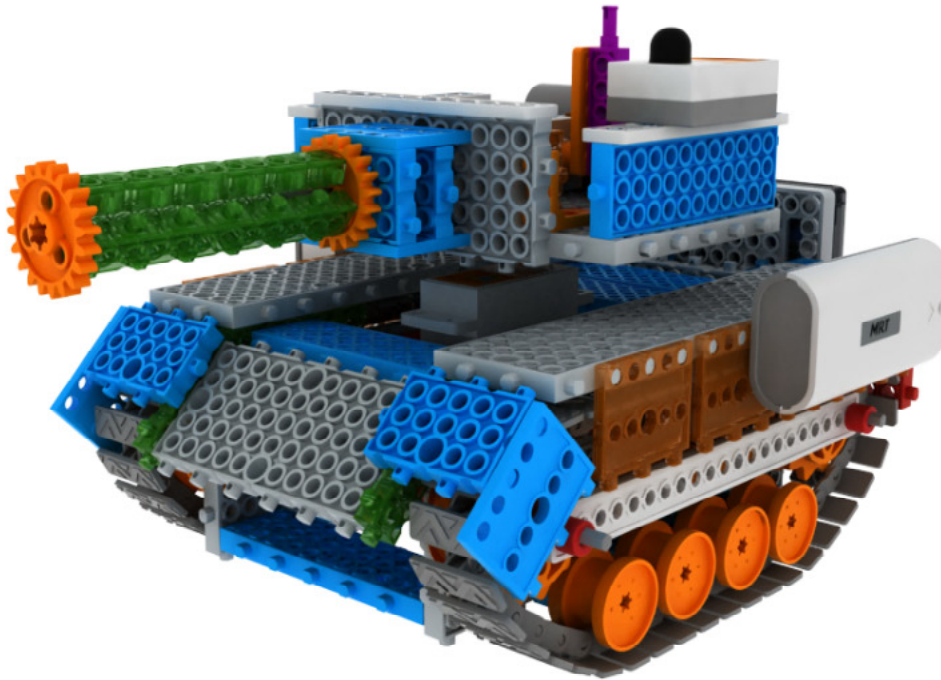

1

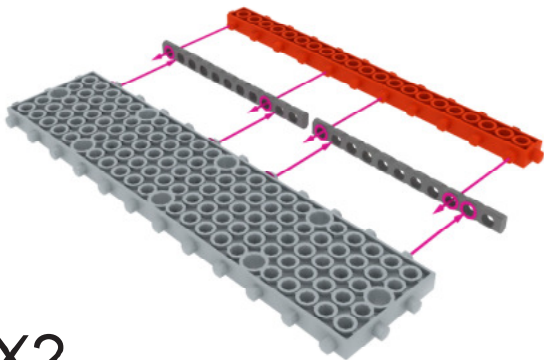

X2

2

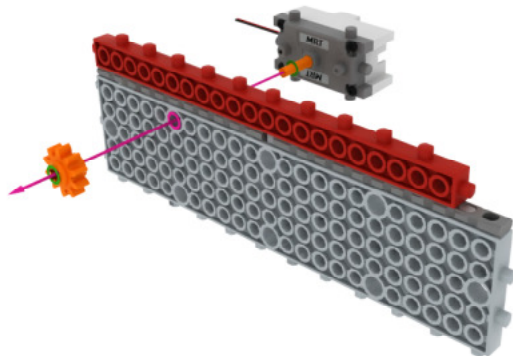

MY ROBOT TIME

3

X1 X1 X1
X1

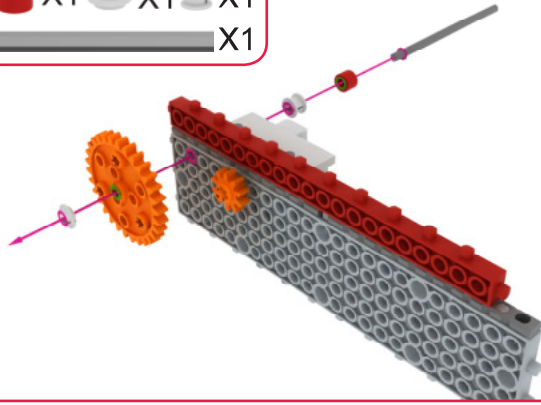

1:1

4

X1 X2
X1

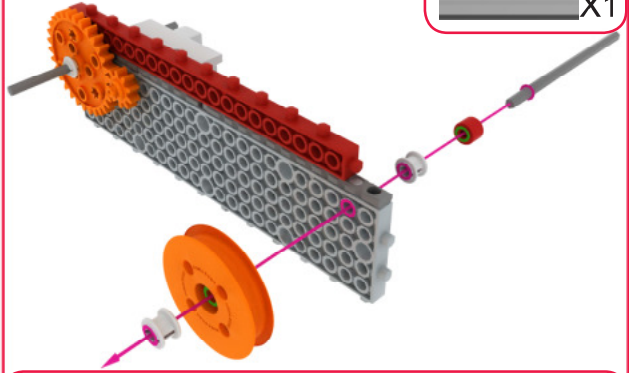

1:1

5

X2

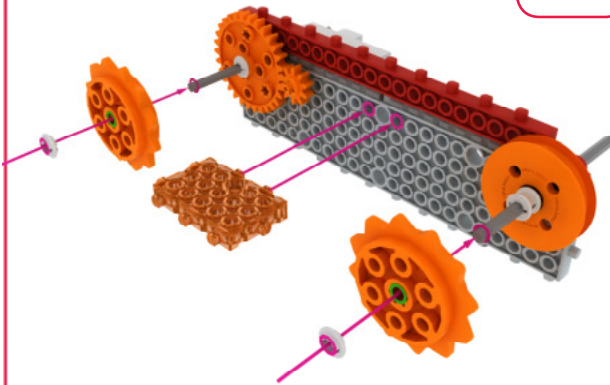

6

X2

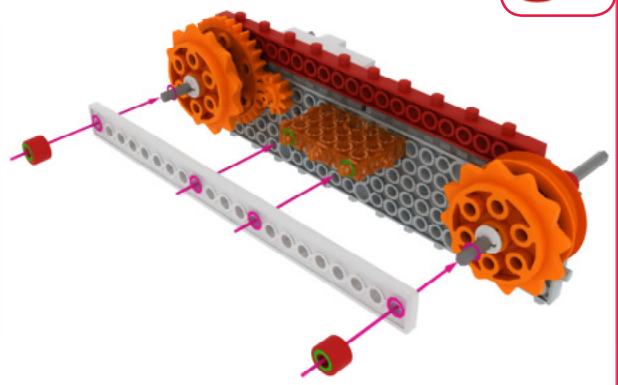

7

X4 X8
X4

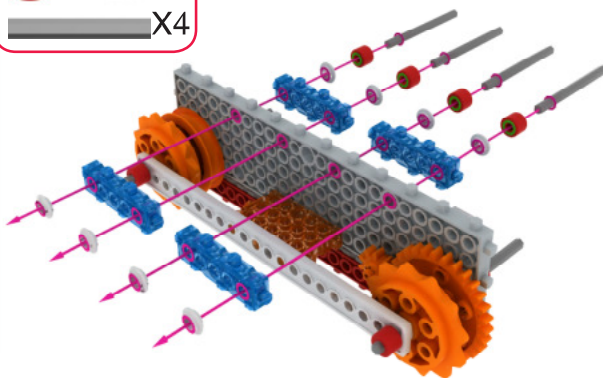

1:1

8

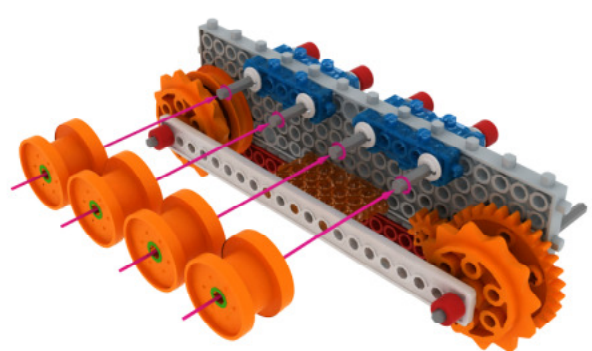

Advanced Level

9

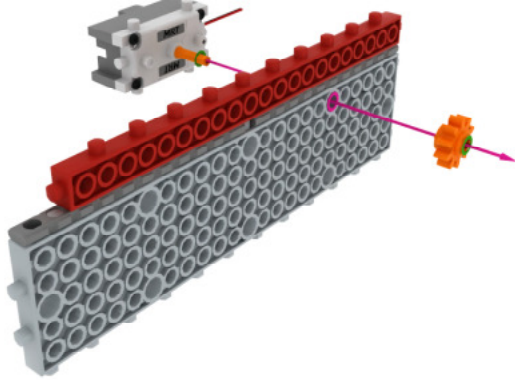

10

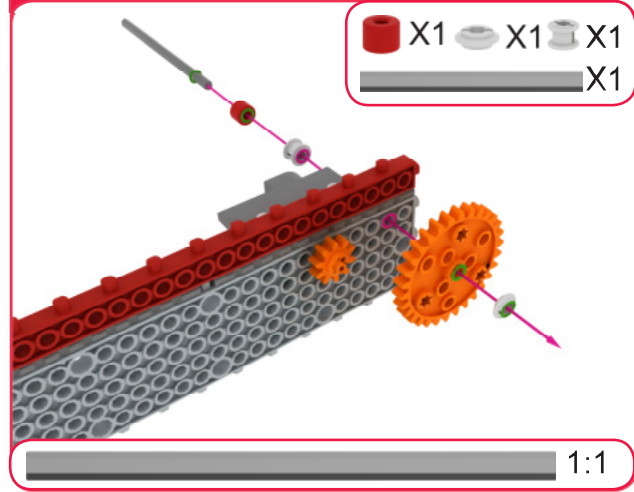

11

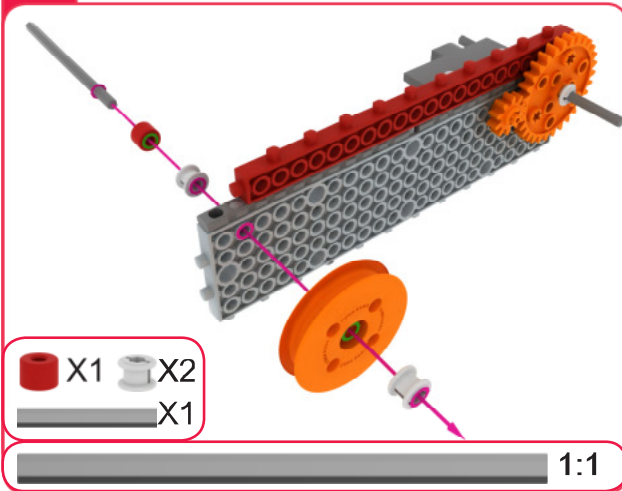

12

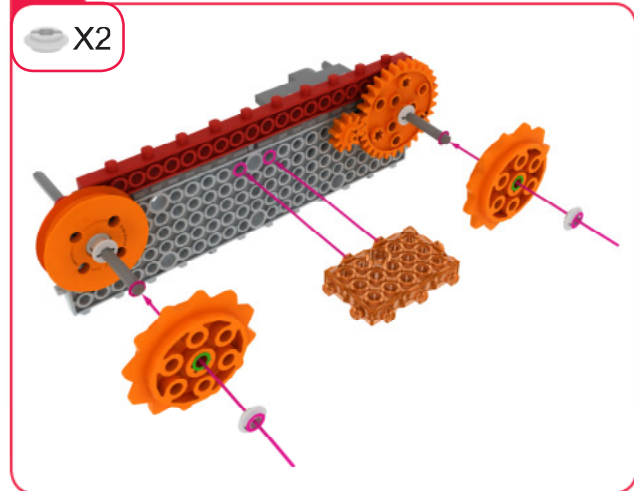

13

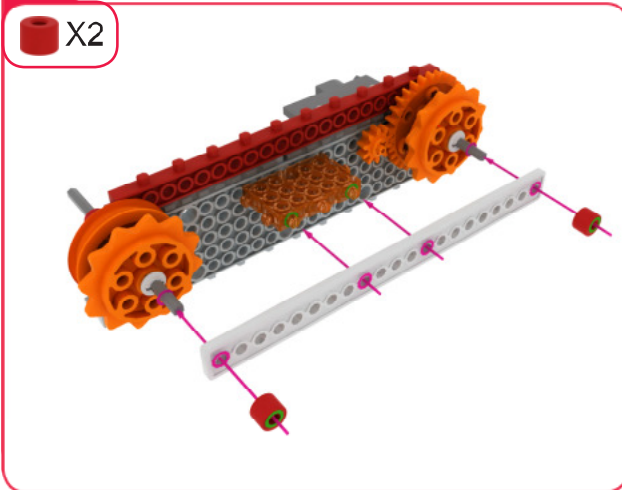

14

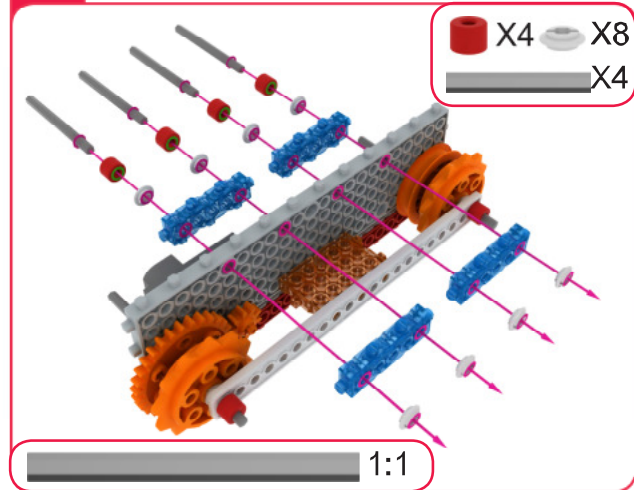

15

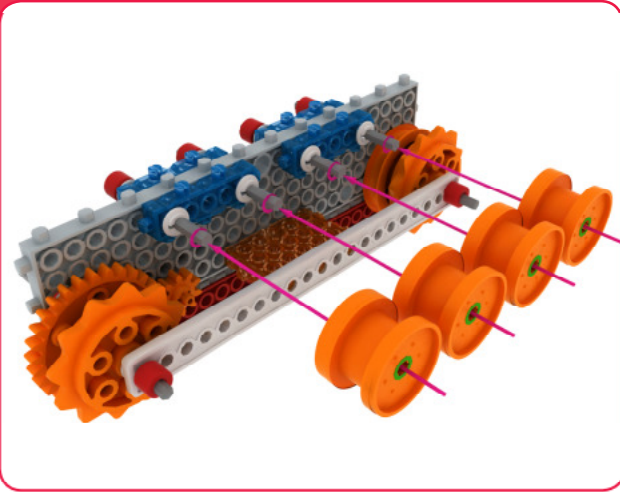

16

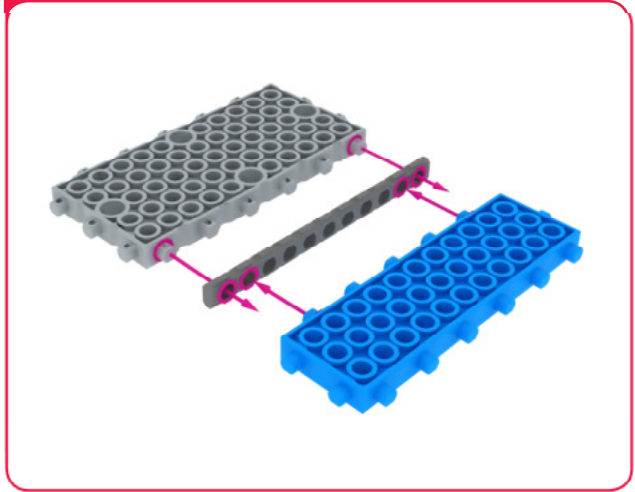

17

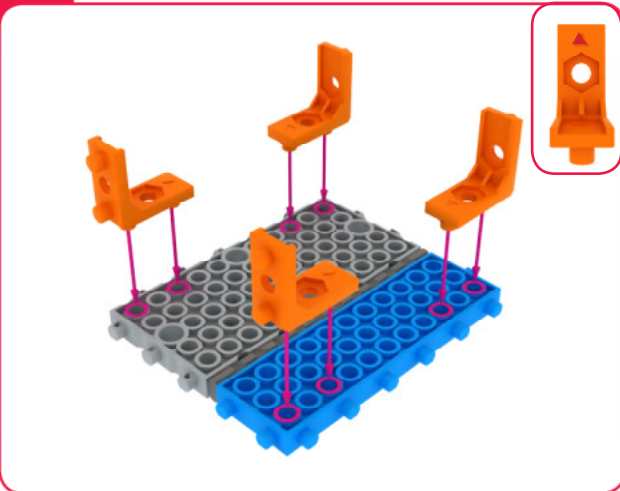

18

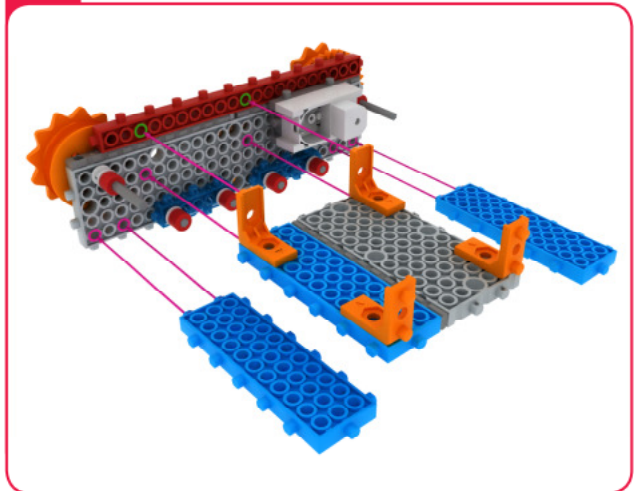

19

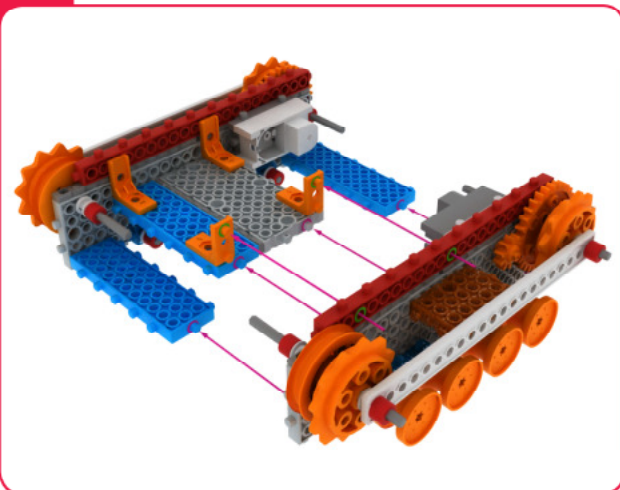

20

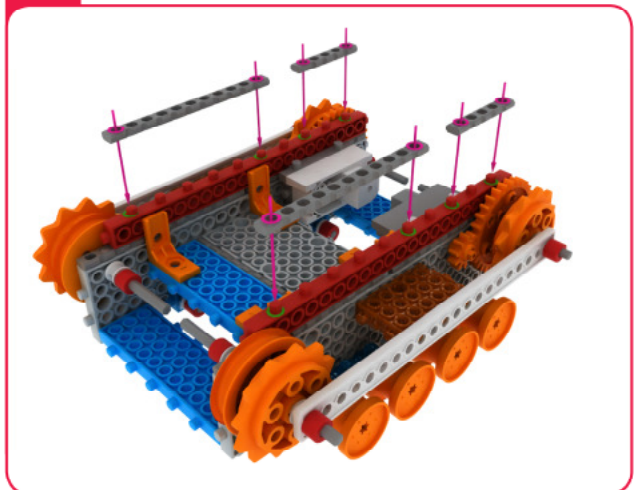

21

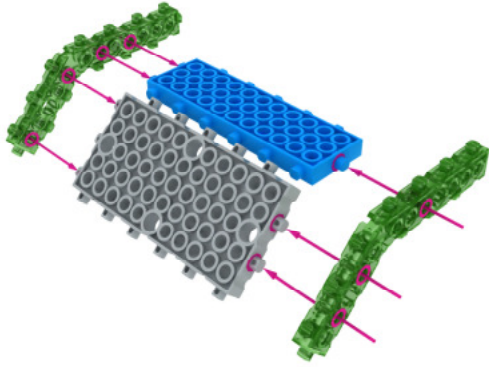

22



23

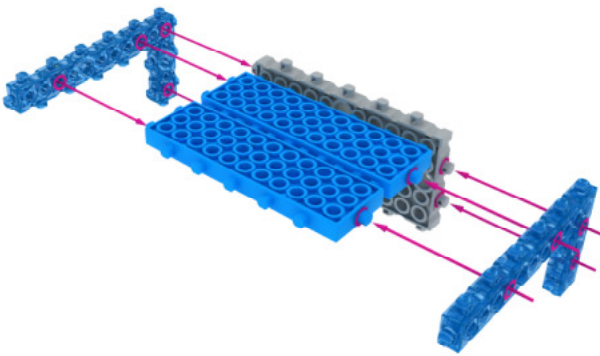

24

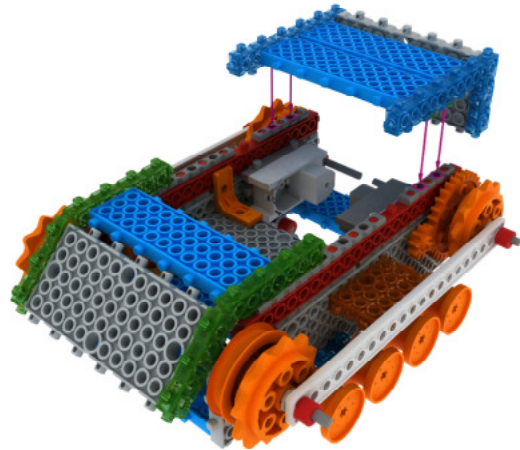

25

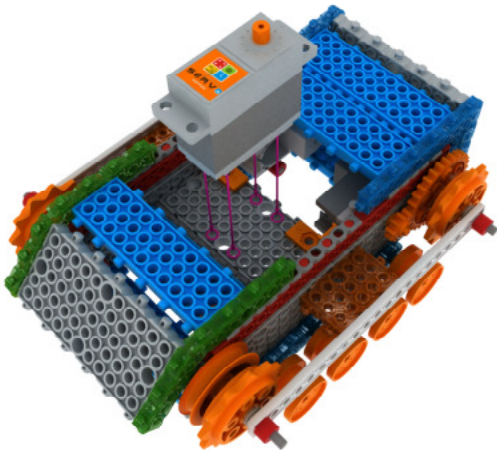

26

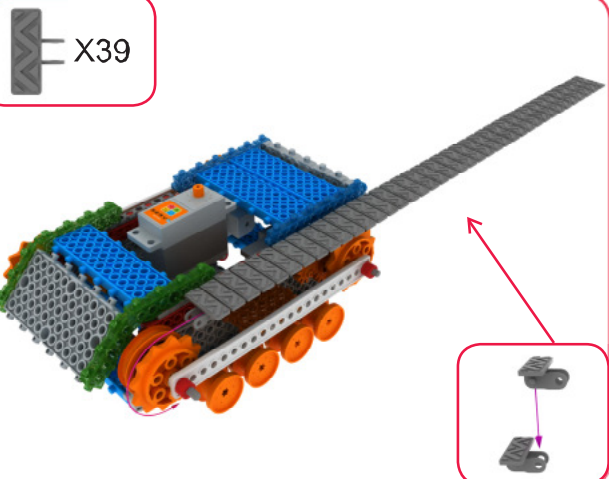

27

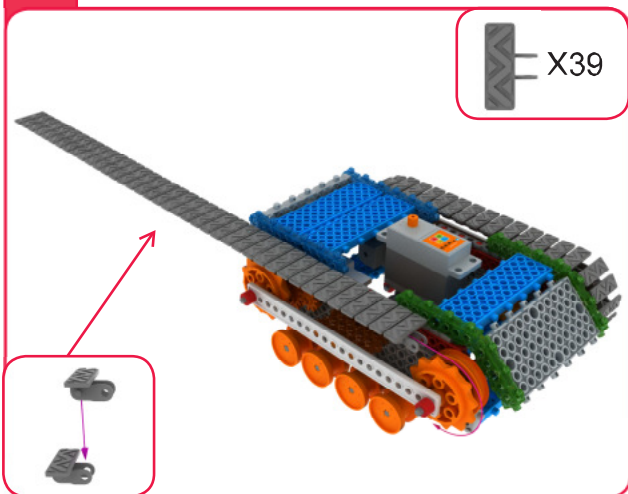

28

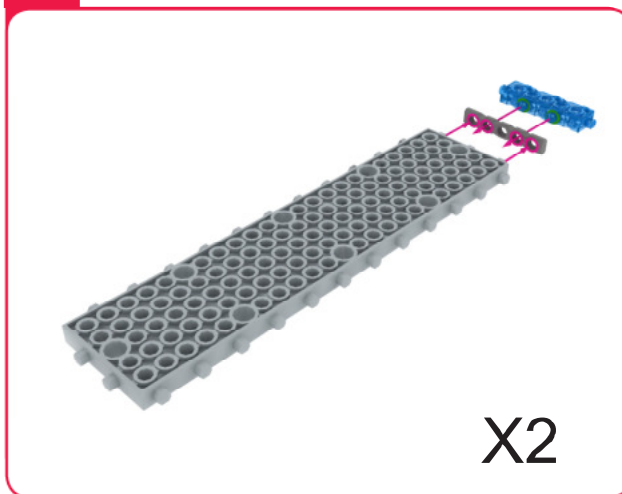

29

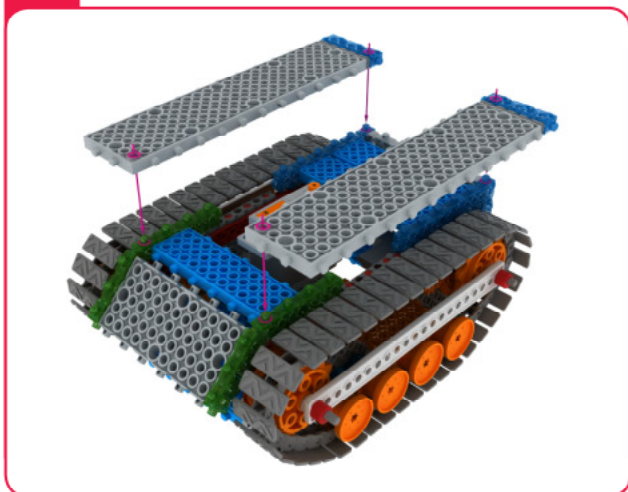

30

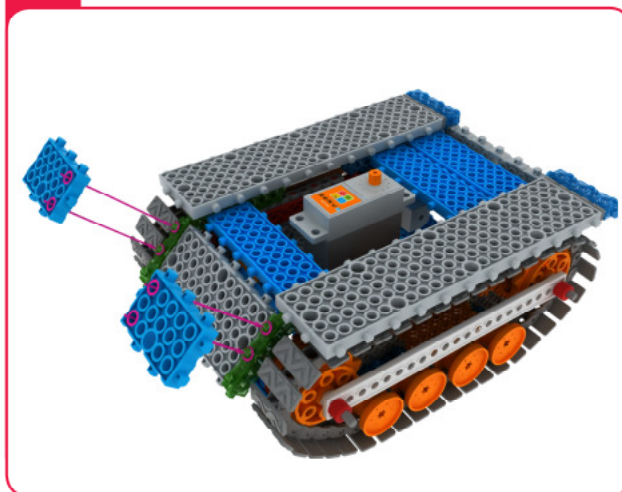

31

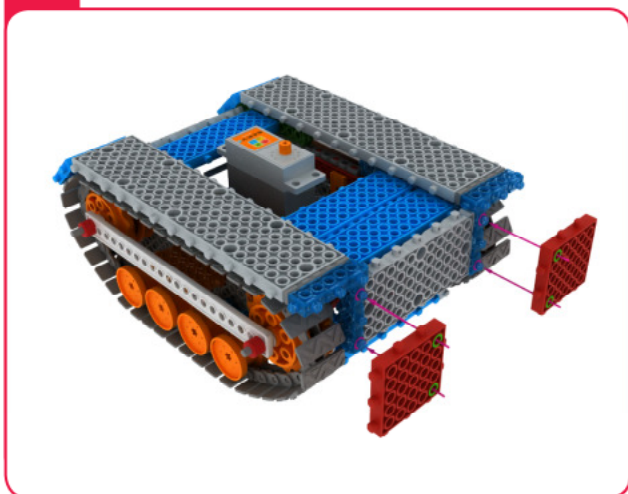

32

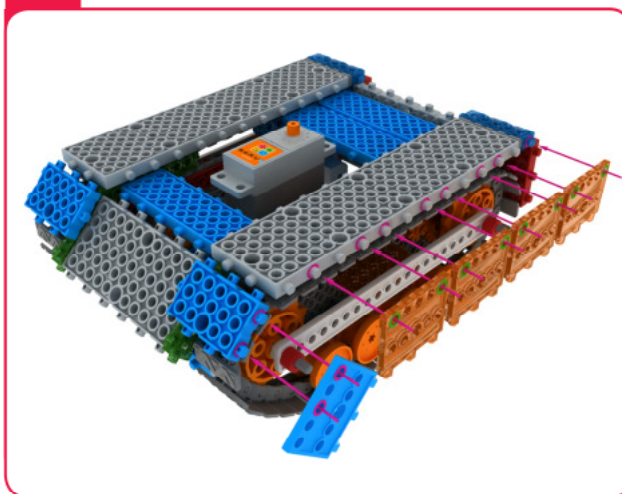

33

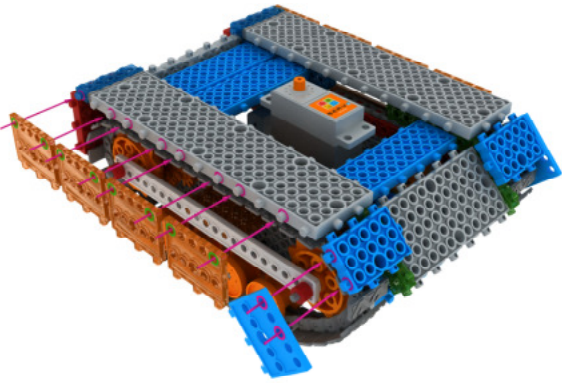

34

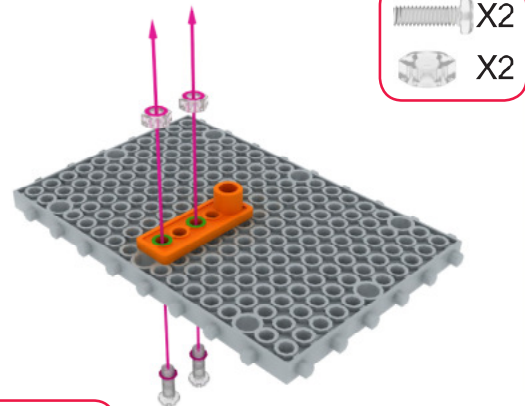

35

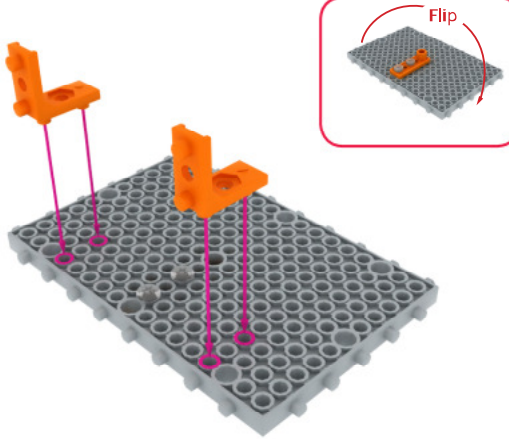

36

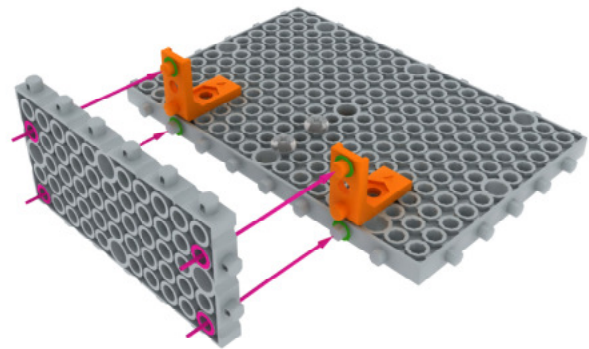

37

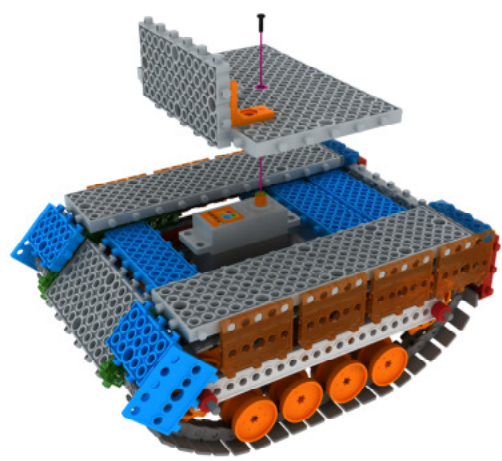

Servo Motor-Zero Point Adjustment

1. Connect the servo motor to the mainboard. You can write the program in the following way.

```

PROGRAM
START {
  Servo:[Servo 1(OUT1)]=[0]
END}
    
```



2. After downloading the program, power off and on again.
3. Fix servo motor horn to the servo motor with a small servo bolt as illustrated in the picture .

38

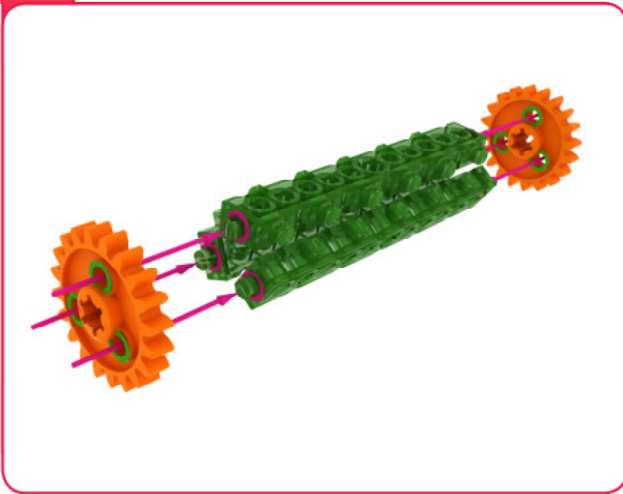

39

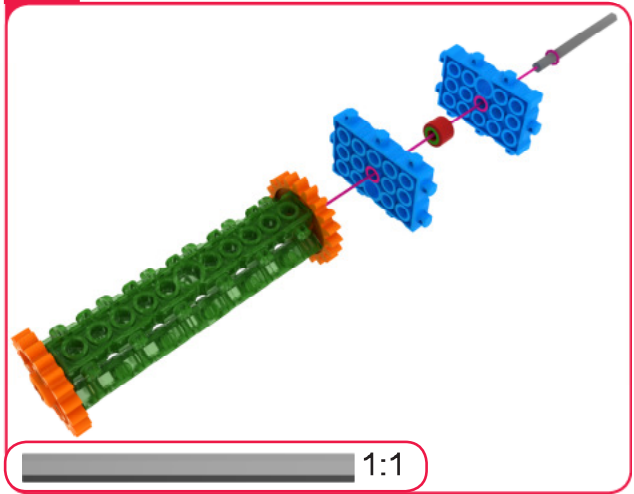

40

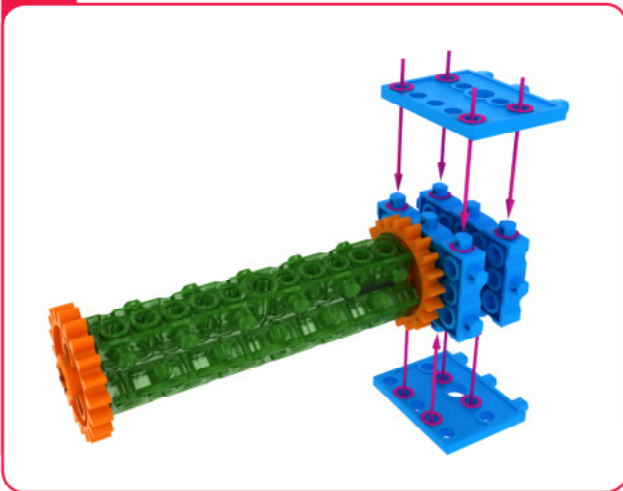

41

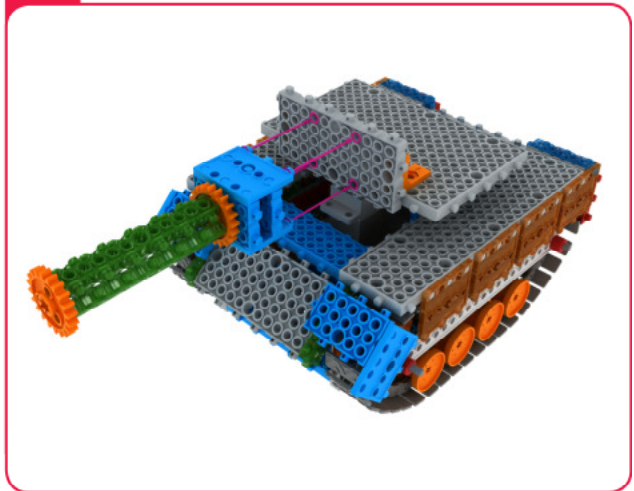

42

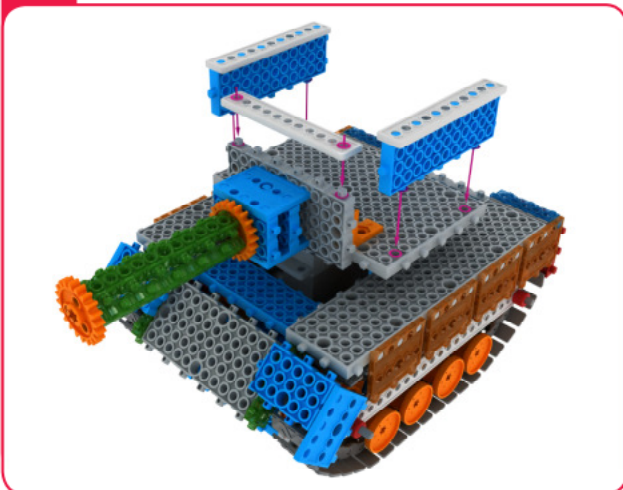

43

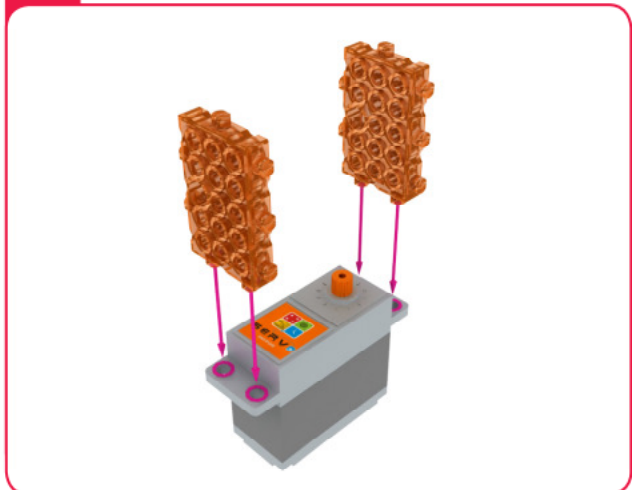

44

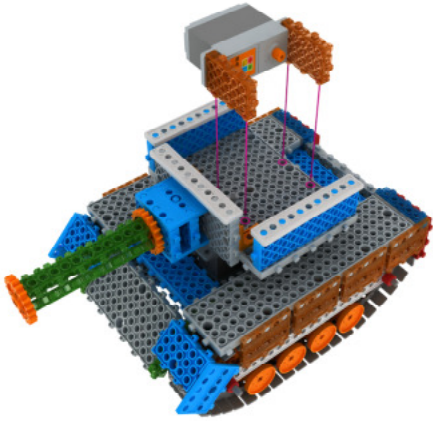

45

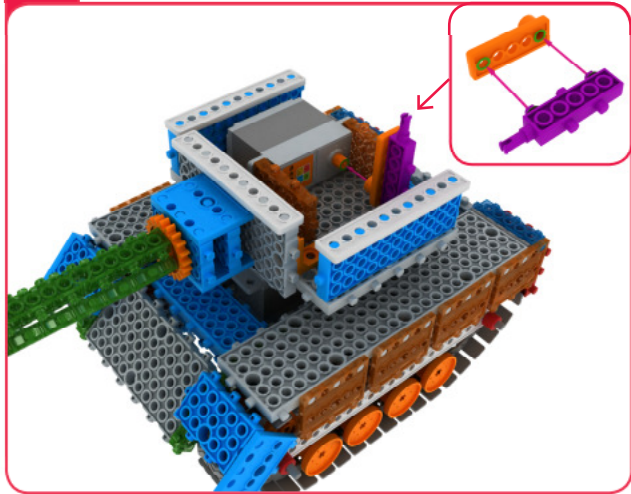

Servo Motor-Zero Point Adjustment

1. Connect the servo motor to the mainboard. You can write the program in the following way.

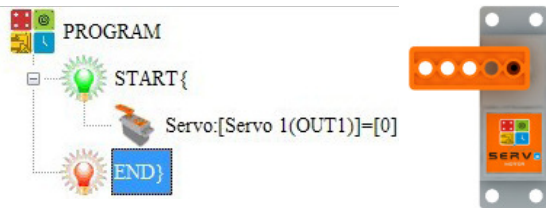

2. After downloading the program, power off and on again.
3. Fix servo motor horn to the servo motor with a small servo bolt as illustrated in the picture .

46

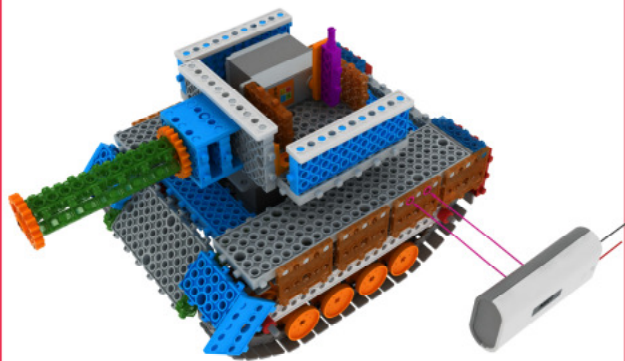

47

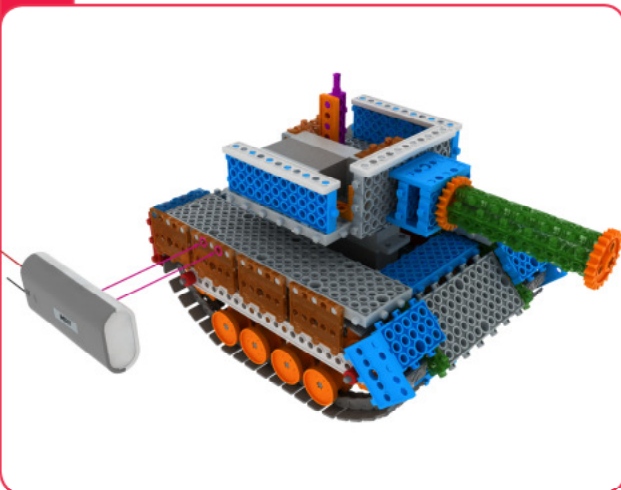

48

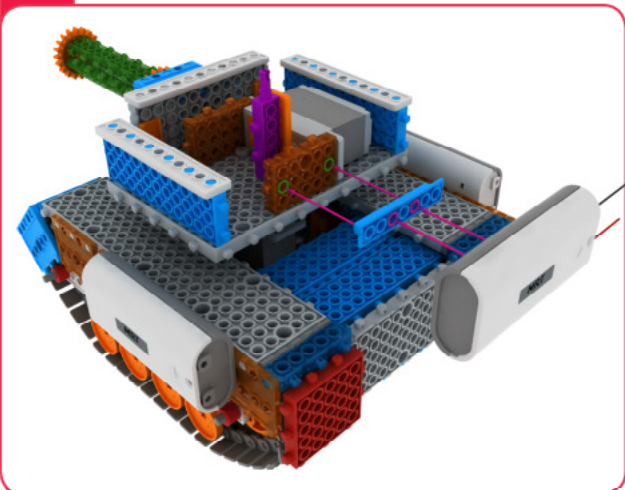

49

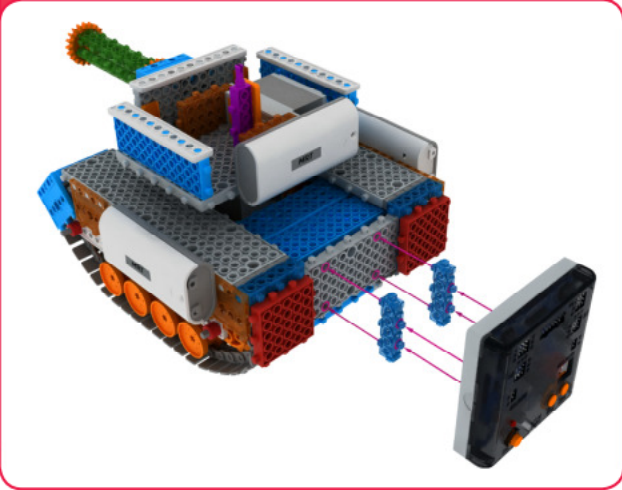

50

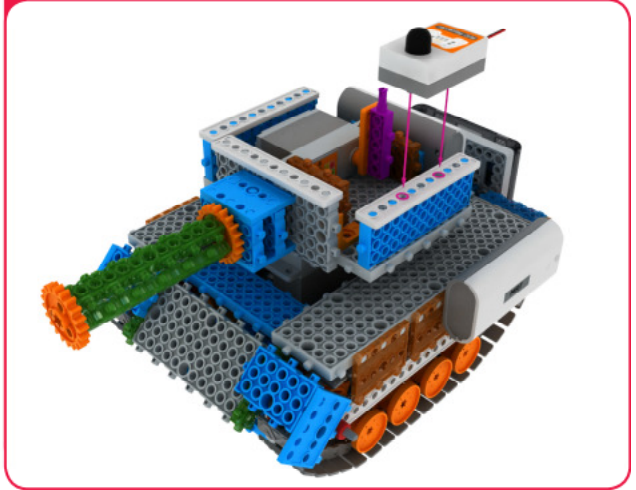

End

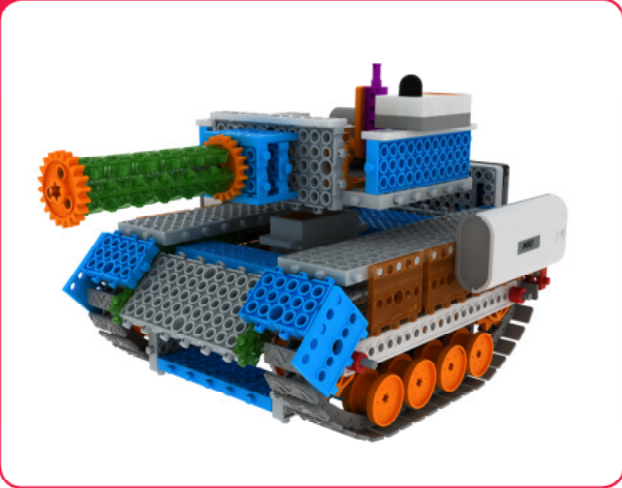



How to operate the TANK

Connecting the main board

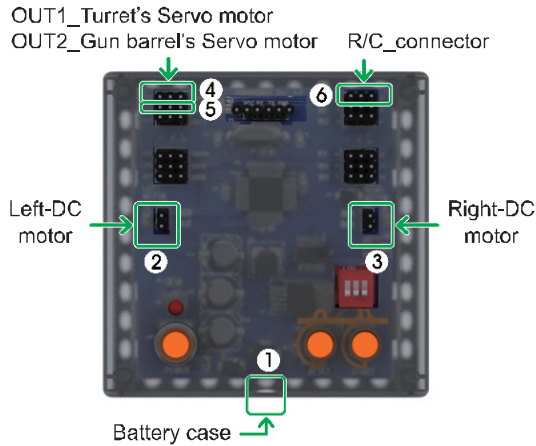

Connect in this order.

1. Connect Battery Cases to Power connector.
2. Connect Left-DC motor to Left-motor connector.
3. Connect Right-DC motor to Right-motor connector.
4. Connect Turret's Servo motor to OUT1 of OUTPUT connector.
5. Connect Gun barrel's Servo motor to OUT2 of OUTPUT connector.
6. Connect RC receiver board to R/C connector.

Motion Pattern/Program

- ※ Driving
- Forward
 - Backward
 - Turn left
 - Forward+Turn left
 - Turn Right
 - Forward+Turn Right
 - Stop

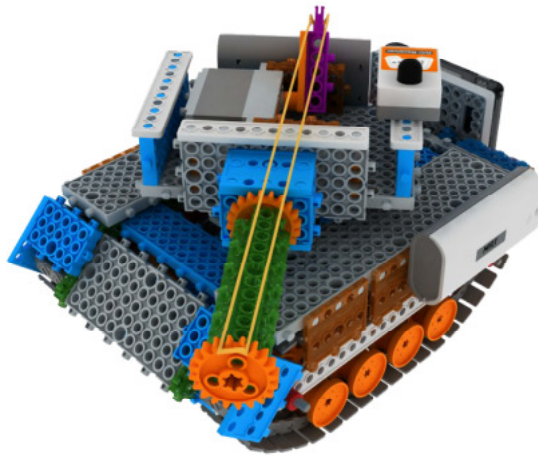

- ※ Aiming / Fire
- F1 → Left 45 degree
 - F2 → Front side
 - F3 → Right 45 degree
 - F5 → Fire / Reloading

※ Using the motion patterns as reference, let's write the program.

Program Download

1. Write the program.
2. Make sure Power / DC Motor connector and sensor's connector are well connected.
3. Check the power OFF state, then insert the download cable.
4. 'SAVE' and click the 'DOWNLOAD' button on the program window.
5. Turn on the power when 'DOWNLOAD' window opens. (Power ON)
6. Once the download is completed, remove the download cable and then turn the power off and on.
(Power OFF → Power ON)

Program Example

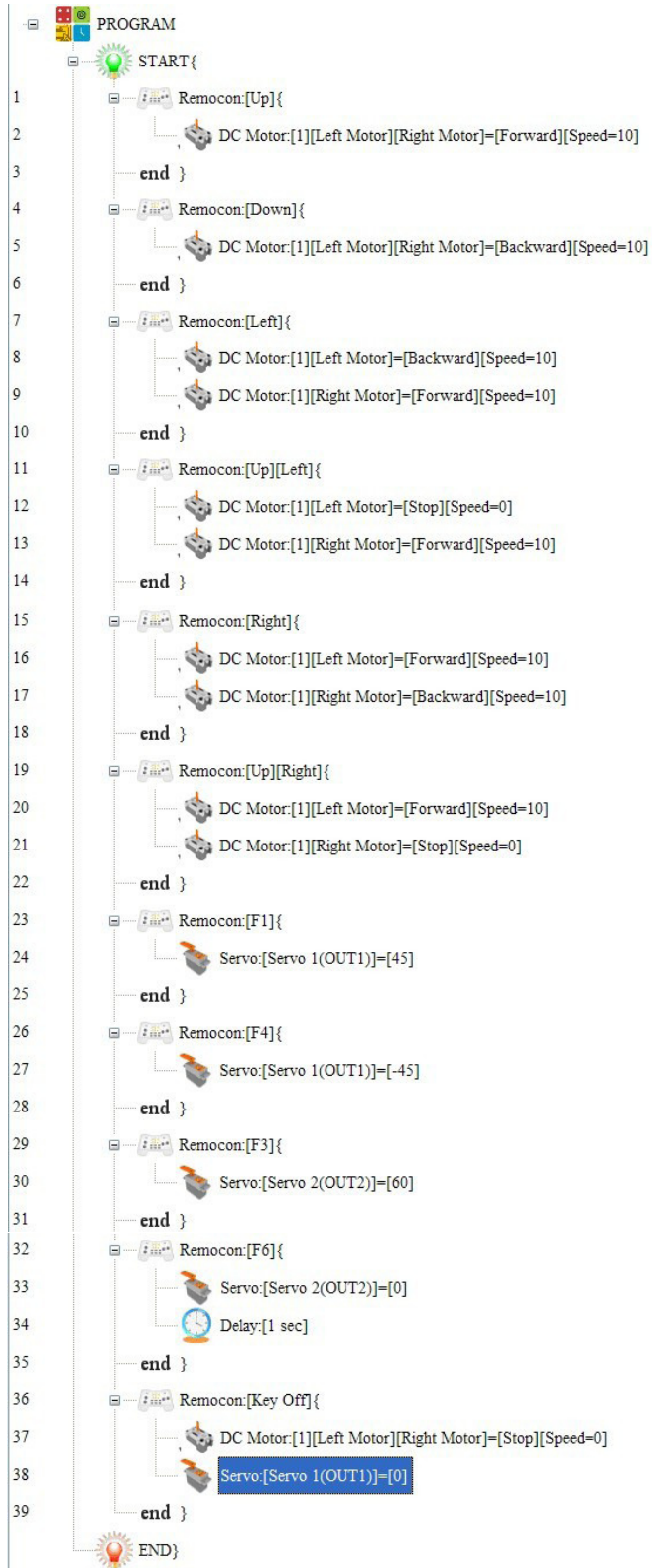

 **Technology**
 **Art** **Shooting Game**

※ Make the target with the rest blocks then play the game with your friends.

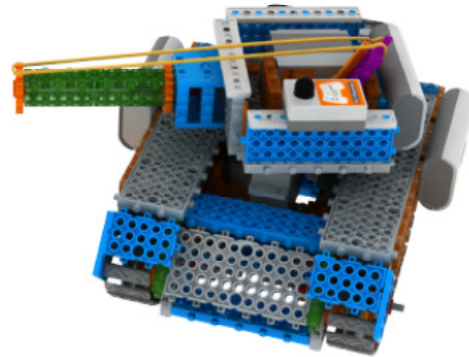
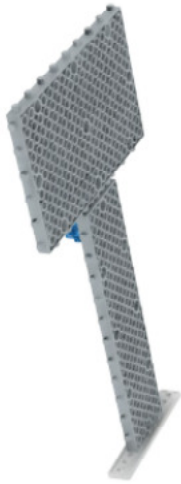

MRT3-4

Revised edition ◆ Aug.20.2013

Publisher ◆ MRT International Limited.

Address ◆ 512-15, Deung chon-Dong, Gang Seo-Gu, Seoul, Korea.

Web ◆ www.myrobottime.com

Art & Compile ◆ MRT ROBOTICS

Copyrights (c) 2013 MRT International Ltd.

※ Reproduction ,translation or audio-visual products of any part of this book without permission of the copyright owner is unlawful.